

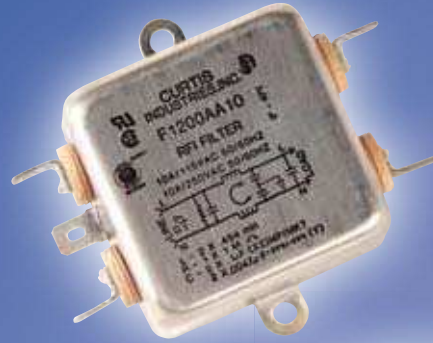

Curtis

We Build Confidence!



RFI Power Line Filters

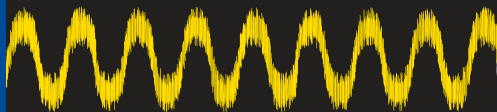

Curtis Industries

A Div. of Powers Holdings, Inc.

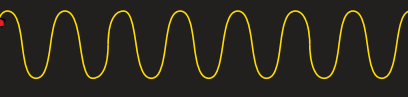



Curtis Industries

A Division of Powers Holdings, Inc.

Curtis Industries is recognized as a leader in RFI Power Line Filters. We focus on five key areas to insure high quality filters and total customer satisfaction using the latest technology. These key areas include Customer Satisfaction, Design Engineering, Manufacturing, Quality, and On-Time Delivery.



Customer Satisfaction is carried out throughout Curtis. Customer interface with our friendly and knowledgeable Customer Service Representative where all the information needed for order entry, processing, shipping, pricing, and order expediting are immediately available electronically.



Design Engineering is able to create new designs to solve our OEM customer's requirements. Using the Solid Works modeling technology enables our engineers to design the optimum filter or custom control package.



Manufacturing uses proprietary techniques with semi and full automation to build in quality and reduce thru-put. We deliver 99.9% reliable product to meet our customer's quality objectives.



Quality is designed, built in and verified on every filter to the following.

- Hi Pot - DC Line to Line
- Hi Pot - AC Line to Ground
- Current Leakage
- Ground Continuity
- Capacitance Line to Line
- Capacitance Line to Ground
- Inductance Line
- Inductance Ground
- Cross Wiring



On-Time Delivery is a focus for everyone at Curtis which has resulted in an on-time delivery greater than 98% on time.

Contents

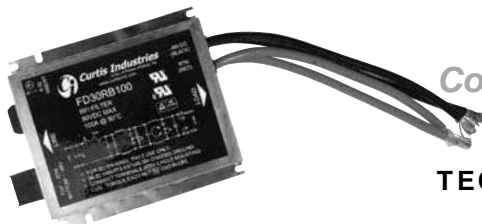
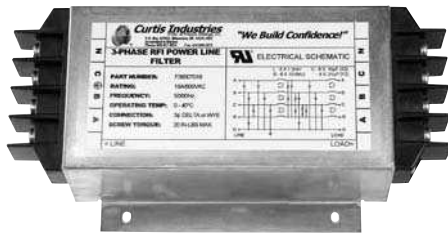
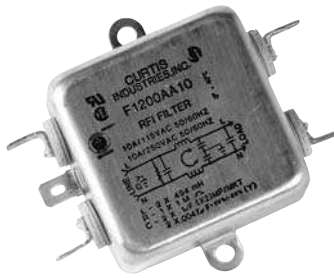

Selection Guide 2

SINGLE PHASE FILTERS]

General Purpose

F1100/F1150/F1199 4
 F1200/F1250/F1299 7
 F1300/F1350/F1399 11
 F1900 15

High Performance

F1400 16
 F1500 18
 F1600 20
 F1700/F1799 22
 F1760/F1770/F1780 24
 F2800 26

Wide Band

F5100 28
 F5200 30
 F5500 32
 F5600 34
 F5700 36
 F5900 38
 Single Phase Filter Cutouts 40

POWER ENTRY MODULES]

General Purpose Filtered Modules

F2199/F2200 44
 F2300 45
 F2400/F2500 46
 F2600 48
 F2700 50

Combination

PE7/PE8 52
 PE1 56
 Power Entry Module Cutouts 58

THREE-PHASE FILTERS]

F3480/F3600 60

DC FILTERS]

FD Series 64

General Purpose

FD00 67
 FD02 68

High Performance

FD1 69
 FD2 70
 FD3 70

MEDICAL FILTERS]

General Purpose Filtered Modules

F3099 72
 F3000/3100/F3199/F3200/F3400/F3500 73
 F3300 76

Combination

PM7/PM8 77
 PM1 81

TECHNICAL CONSIDERATIONS]

Understanding Terminology 84
 Technical Considerations 86
 Conducted Emissions Testing 88
 Custom Filter Capabilities 89

Curtis Industries Filter Selection Guide

Filter Series	PERFORMANCE		MAXIMUM		PACKAGE/TERMINATION									Catalog Page Number	
	RELATIVE ATTENUATION		LEAKAGE CURRENT		Wire	Q.C.	I.E.C.	Fused I.E.C.	Volt Select	Switch	P.C. Term	Screw	Solder Term.		
	Common Mode	Differential Mode	mA @115VAC	mA @250VAC											
SINGLE PHASE	F1100/1199	••	••	0.5	1.0	•	•					•	•	•	4
	F1150	•	•	0.25	0.40	•	•						•	•	4
	F1200/1299	••	••	0.5	1.0	•	•	•					•	•	7
	F1250	•	••	0.25	0.40	•	•						•	•	7
	F1300/1399	••••	••	0.5	1.0	•	•	•				•		•	11
	F1350	•••	••	0.25	0.40	•	•	•				•		•	11
	F1900	•	•	0.25	0.40		•							•	15
	F1400	•••••	••••	0.25	0.40	•	•	•						•	16
	F1500	••••	•••	0.25	0.40		•	•	•					•	18
	F1600	•••••	•••	0.25	0.40		•	•	•			•		•	20
	F1700/1799	••	••••	0.5	1.0	•	•	•					•	•	22
	F1760/1700/1780	••••	••••	0.5	1.0	•	•	•					•	•	24
	F2800	•••••	•••••	0.25	0.50	•	•							•	26
	F5100	••	••	0.25	0.50			•						•	28
	F5200	••	••	0.25	0.50				•					•	30
	F5500	••••	••••	0.25	0.50			•						•	32
	F5600	•••••	••••	0.50	1.20			•						•	34
	F5700	••••	•••••	0.50	1.20			•						•	36
	F5900	•••••	••••	0.50	1.20			•						•	38
POWER ENTRY	F2199/2200	•	•	0.25	0.40		•	•						•	44
	F2300 F2300	•••	••	0.25	0.40		•	•						•	45
	F2400/2500	•	•	0.25	0.40		•	•						•	46
	F2600	•	•	0.25	0.40		•	•	•		•	•		•	48
	F2700	•••••	•••••	0.25	0.40	•	•	•	•		•			•	50
	PE7	•	•	0.25	0.40		•		•	•				•	52
	PE8	•	•	0.25	0.40		•		•		•			•	52
	PE1	••	••	0.25	0.40		•		•	•	•			•	56
	F3480/F3600	••••	••••				•						•		60
DC FILTERS	FD00	(See Section on DC filters for more information)												67	
	FD02													68	
	FD1													69	
	FD2													70	
	FD3													70	
MEDICAL	F3099	•	••	0.002	0.005	•	•							•	72
	F3000/3100/3200/3400/3500	•	••	0.002	0.005		•	•						•	73
	F3300	•	•	0.015	0.025		•	•	•		•	•		•	74
	PM7	•	•	0.002	0.005		•		•	•				•	76
	PM8	•	•	0.002	0.005		•		•	•				•	76
	PM1	••	••	0.002	0.005		•		•	•	•			•	80



SINGLE PHASE FILTERS]

General Performance

High Performance

Wide Band

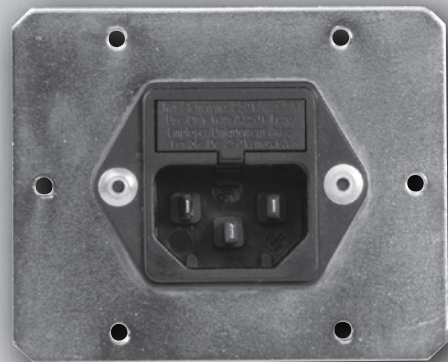
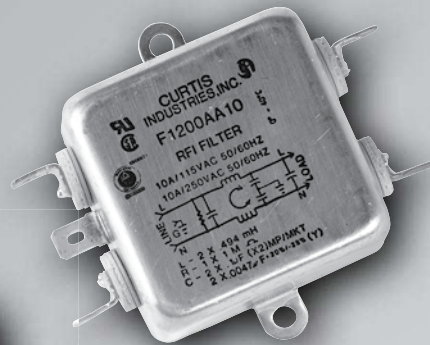

F1100/F1150F/F1199 RFI Filters

General Purpose

SINGLE PHASE FILTERS

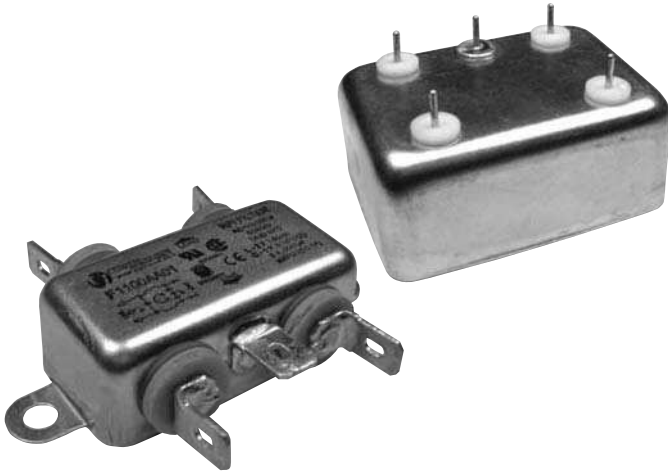

Features:

- Most Economical Design
- Designed for General Purpose, Common Mode Applications
- Available in Standard (F1100) and Low-Leakage (F1150) (F1160) (F1170) (F1180) (F1190) (F1199) Models

F1100/F1150/F1199 Simplified Schematic

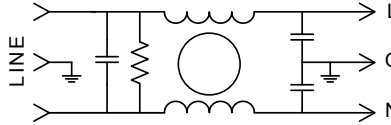

Nominal Current Rating 115 VAC	Part Number	Termination Line/Load	MINIMUM INSERTION LOSS - dB (50 ohm Circuit)						
			MODE	Frequency - MHz					
				.15	.50	1.0	5.0	10	30
1A	F1100AA01 F1100BB01	QC/QC Wire/Wire	Common Differential	20	35	43	52 55	55 65	50 50
	F1150AA01 F1150BB01	QC/QC Wire/Wire	Common Differential	20	30	37	50 55	50 65	50 50
	F1199AA01	QC/QC	Common Differential	32 5	45 14	45 23	43 47	43 50	40 45
2A	F1199AA02 F1199BB02	QC/QC Wire/Wire	Common Differential	24 5	35 13	43 16	45 45	45 50	40 45
	3A	F1100AA03 F1100BB03 F1100PP03	QC/QC Wire/Wire PC/PC	Common Differential	20	35	43	52 55	55 64
F1150AA03 F1150BB03		QC/QC Wire/Wire	Common Differential	20	30	37	50 55	50 64	50 46
F1199AA03 F1199BB03		QC/QC Wire/Wire	Common Differential	20 5	30 12	38 14	48 38	48 44	44 42
6A	F1100AA06 F1100BB06	QC/QC Wire/Wire	Common Differential	10	22 2	30 5	46 51	50 57	45 49
	F1150AA06 F1150BB06	QC/QC Wire/Wire	Common Differential	10	20 2	27 5	45 51	45 57	45 49
	F1199AA06 F1199BB06	QC/QC Wire/Wire	Common Differential	9 5	20 12	28 14	42 33	50 42	47 42
10A	F1100AA10 F1100BB10	QC/QC Wire/Wire	Common Differential	10	22	30 2	46 27	50 47	45 50
	F1150AA10 F1150BB10	QC/QC Wire/Wire	Common Differential	10	20	27 2	45 27	45 47	45 50
	F1199AA10 F1199BB10 F1199DD10	QC/QC Wire/Wire Screw/Screw	Common Differential	9 5	20 12	25 14	38 33	42 42	40 42
20A	F1100AA20 F1100DD20	QC/QC Screw/Screw	Common Differential	8	18	22 5	36 22	42 46	45 60
	F1150AA20 F1150DD20	QC/QC Screw/Screw	Common Differential	8	15	20 5	32 22	38 46	45 60
	F1199AA20 F1199DD20	QC/QC Screw/Screw	Common Differential	10 5	20 12	28 15	35 30	38 40	40 40
30A	F1199DD30	Screw/Screw	Common Differential	13 5	23 12	30 15	35 30	38 40	40 40

NOTE: Other combinations of terminals may be specified on special order.



Specifications:

Rated Voltage: 250VAC Maximum - 50/60 Hz

Rated Current:	115VAC	250VAC
	1A	1A
	2A	1.5A
	3A	2.5A
	6A	4A
	10A	6A
	20A	10A
	30A	15A

Current Overload: 6X for 8 seconds

Hi-Pot Test (1 min):	F1100/F1150	F1199
Line to Ground:	1500VAC	1500VAC
Line to Line:	1768VDC	1450VDC

Insulation Resistance: $9 \times 10^9 \Omega$ at 100VDC

Ambient Temperature: 40°C Max. at rated current

Humidity Range: 0% to 95% R.H.

Termination:

- A: QC – Quick Connect
- B: Wire
- D: Screw
- P: PCB Mount

Maximum Leakage Current:

Each Line to Ground	F1100	F1150	F1199
115VAC, 60Hz:	0.40mA	0.25mA	0.25mA
250VAC, 50Hz:	.75mA	0.40mA	0.45mA

Agency Approvals:



	F1100	F1100	F1100
F1150	F1500	Except 20Amp	F1150
F1199	F1199	F1199	F1199

F1100DD/F1150DD
(20Amp Only) Dimensions

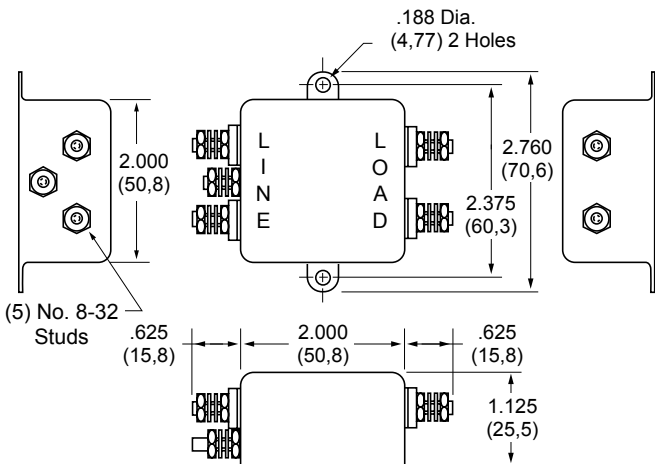

F1100AA/F1150AA
(1, 3, 6, 10 and 20Amp) Dimensions

Amps	A	B	C	D	E
1A	2.500 (63,5)	1.750 (44,5)	.625 (15,8)	2.125 (53,9)	1.425 (36,2)
3A	2.500 (63,5)	1.750 (44,5)	.750 (19,1)	2.125 (53,9)	1.8 (45,8)
6A	2.500 (63,5)	1.750 (44,5)	.750 (19,1)	2.125 (53,9)	1.8 (45,8)
10A	2.500 (63,5)	1.750 (44,5)	1.125 (28,5)	2.125 (53,9)	1.8 (45,8)
20A	2.760 (70,6)	2.000 (60,8)	1.125 (28,5)	2.375 (60,3)	2.550 (64,8)

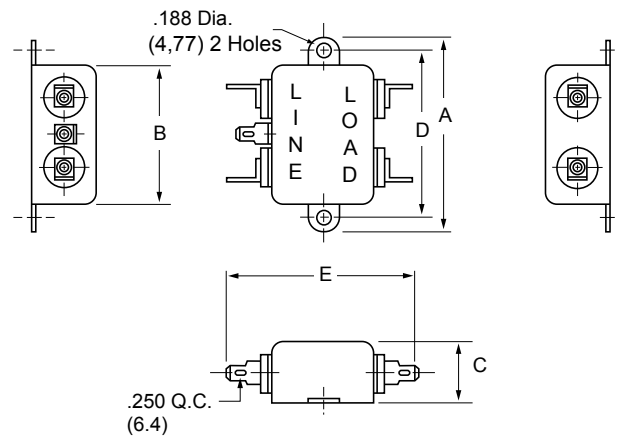

F1100BB/FB1150BB
(1, 3, 6 and 10Amp) Dimensions

Amps	A	B	C	D	E
1A	2.500 (63,5)	1.750 (44,5)	.625 (15,8)	2.125 (53,9)	.875 (22,2)
3A	2.500 (63,5)	1.750 (44,5)	.750 (19,1)	2.125 (53,9)	1.250 (31,8)
6A	2.500 (63,5)	1.750 (44,5)	.750 (19,1)	2.125 (53,9)	1.250 (31,8)
10A	2.500 (63,5)	1.750 (44,5)	1.125 (28,5)	2.125 (53,9)	1.250 (31,8)

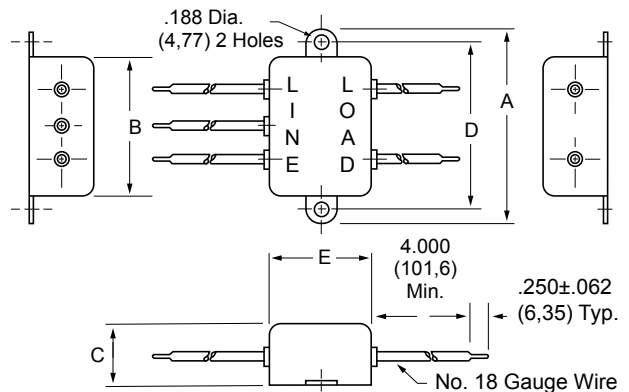

Dimensions are in inches and millimeters unless otherwise specified. Values in parentheses are metric equivalents.



F1100/F1150/F1199 RFI Filters (continued)

General Purpose

SINGLE PHASE FILTERS

F1199AA (1, 2, 3, 6, 10 and 20Amp) Dimensions

Amps	A	B	C	D	E
1A	2.53 (64,3)	1.82 (46,2)	0.66 (16,8)	2.126 (54,0)	2.25 (57,2)
2A	2.53 (64,3)	1.82 (46,2)	0.66 (16,8)	2.126 (54,0)	2.25 (57,2)
3A	2.53 (64,3)	1.82 (46,2)	0.78 (19,8)	2.126 (54,0)	2.61 (66,3)
6A	2.53 (64,3)	1.82 (46,2)	0.78 (19,8)	2.126 (54,0)	2.61 (66,3)
10A	2.53 (64,3)	1.82 (46,2)	1.16 (29,5)	2.126 (54,0)	2.61 (66,3)
20A	2.81 (71,4)	2.07 (52,6)	1.16 (29,5)	2.375 (60,33)	3.36 (85,3)

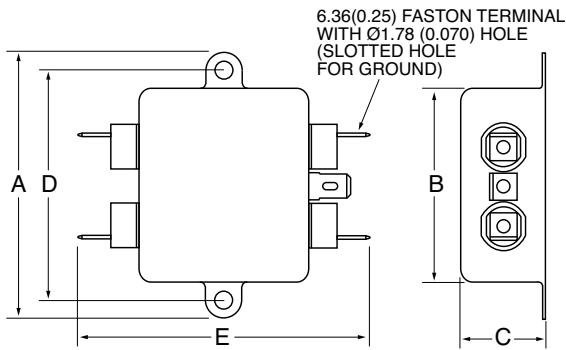

F1199BB (2, 3, 6 and 10Amp) Dimensions

Amps	A	B	C	D	E
2A	2.53 (64,3)	1.82 (46,2)	0.66 (16,8)	2.126 (54,0)	0.96 (24,4)
3A	2.53 (64,3)	1.82 (46,2)	0.78 (19,8)	2.126 (54,0)	1.32 (33,5)
6A	2.53 (64,3)	1.82 (46,2)	0.78 (19,8)	2.126 (54,0)	1.32 (33,5)
10A	2.53 (64,3)	1.82 (46,2)	1.16 (29,5)	2.126 (54,0)	1.32 (33,5)

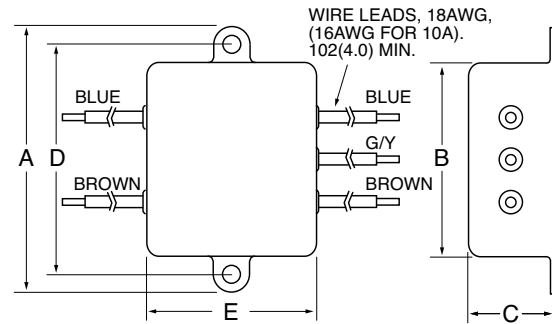

F1199DD (10, 20 and 30Amp) Dimensions

Amps	A	B	C	D	E
10A	2.53 (64,3)	1.82 (46,2)	1.16 (29,5)	2.126 (54,0)	2.72 (69,1)
20A	2.81 (71,4)	2.07 (52,6)	1.16 (29,5)	2.375 (60,33)	3.46 (87,9)
30A	4.20 (106,7)	3.38 (85,9)	1.53 (38,9)	3.75 (95,25)	5.34 (135,6)

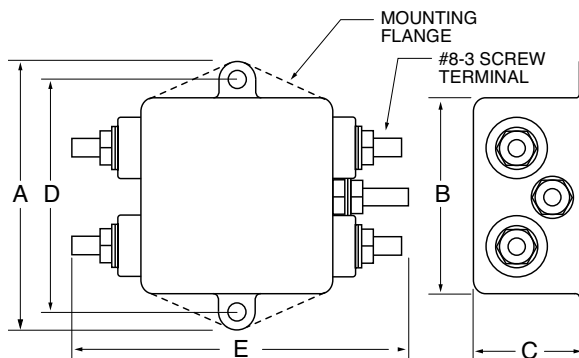

F1100PP Recommended PC Mounting

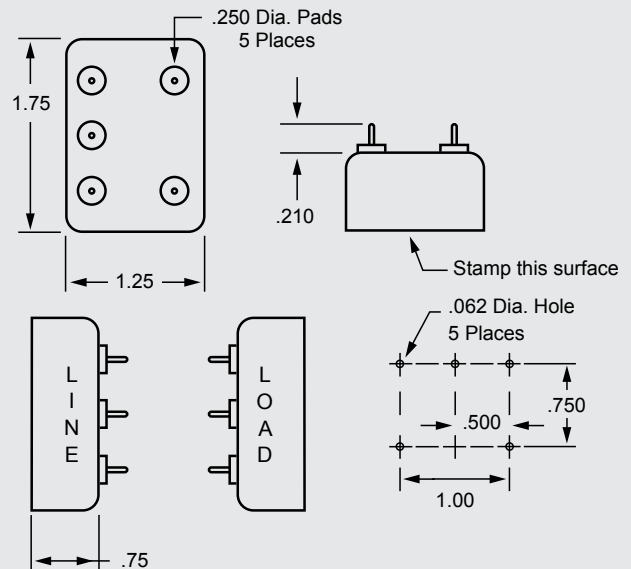

F1200/F1250/F1299 RFI Filters

Features:

- Designed for General Purpose Common Mode and Differential Mode Applications
- Higher Line-to-Line Capacitance for Protection from Pulsed, Intermittent, or Continuous RFI
- Available in Standard (F1200) and Low-Leakage (F1250) (F1260) (F1270) (F1280) (F1299) Models
- Available with Integral IEC Connector up to 10Amps



Nominal Current Rating	Part Number	Termination Line/Load	MINIMUM INSERTION LOSS - dB (50 ohm Circuit)						
			MODE	Frequency - MHz					
				.15	.50	1.0	5.0	10	30
1A	F1200AA01	QC/QC	Common	20	35	43	52	55	50
	F1200BB01	Wire/Wire	Differential	4	38	59	66	62	54
	F1250AA01	QC/QC	Common	20	30	37	50	50	50
	F1250BB01	Wire/Wire	Differential	4	38	59	66	62	54
2A	F1299AA02	QC/QC	Common	24	35	43	45	45	40
	F1299BB02	Wire/Wire	Differential	6	35	50	55	50	45
3A	F1200AA03	QC/QC	Common	20	35	43	52	55	50
	F1200BB03	Wire/Wire	Differential	4	38	59	70	64	59
	F1200CA03	IEC/QC							
	F1250AA03	QC/QC	Common	20	30	37	50	50	50
	F1250BB03	Wire/Wire	Differential	4	38	59	70	64	59
	F1250CA03	IEC/QC							
6A	F1299AA03	QC/QC	Common	26	37	45	45	45	40
	F1299BB03	Wire/Wire	Differential	6	40	55	55	50	45
	F1299CA03	IEC/QC							
	F1200AA06	QC/QC	Common	10	22	30	46	50	45
	F1200BB06	Wire/Wire	Differential	9	25	48	70	70	62
	F1200CA06	IEC/QC							
10A	F1250AA06	QC/QC	Common	10	20	27	45	45	45
	F1250BB06	Wire/Wire	Differential	9	25	48	70	70	62
	F1250CA06	IEC/QC							
	F1299AA06	QC/QC	Common	20	31	40	45	45	40
	F1299BB06	Wire/Wire	Differential	6	35	50	55	50	45
	F1299CA06	IEC/QC							
20A	F1200AA10	QC/QC	Common	10	22	30	46	50	45
	F1200BB10	Wire/Wire	Differential	10	16	43	70	70	66
	F1200CA10	IEC/QC							
	F1250AA10	QC/QC	Common	10	20	27	45	45	45
	F1250BB10	Wire/Wire	Differential	10	16	43	70	70	66
	F1250CA10	IEC/QC							
30A	F1299AA10	QC/QC	Common	9	20	25	38	42	40
	F1299BB10	Wire/Wire	Differential	14	14	38	50	48	45
	F1299CA10	IEC/QC							
	F1299DD10	Screw/Screw							
	F1200AA20	QC/QC	Common	10	22	30	42	47	40
	F1200DD20	Screw/Screw	Differential	9	19	44	70	70	70
30A	F1250AA20	QC/QC	Common	10	20	25	38	40	40
	F1250DD20	Screw/Screw	Differential	9	19	44	70	70	70
	F1299AA20	QC/QC	Common	10	20	28	35	38	40
30A	F1299DD20	Screw/Screw	Differential	14	14	38	50	48	45
	F1200DD30	Screw/Screw	Common	7	15	20	34	42	40
30A	F1299DD30	Screw/Screw	Differential	11	13	44	70	60	57
	F1299DD30	Screw/Screw	Common	12	23	30	35	38	40
30A	F1299DD30	Screw/Screw	Differential	15	40	55	55	55	50

NOTE: Other combinations of terminals may be specified on special order.

Dimensions are in inches and millimeters unless otherwise specified. Values in parentheses are metric equivalents.



Curtis Industries
A Division of Powers Holdings, Inc.

1-800-657-0853

General Purpose

SINGLE PHASE FILTERS

F1200/F1250/F1299 RFI Filters (continued)

Specifications:

Rated Voltage: 250VAC Maximum - 50/60 Hz

Rated Current:

115VAC	1A	2A	3A	6A	10A	20A	30A
250VAC	1A	1.5A	2.5A	4A	6A	10A	15A

Current Overload: 6X for 8 seconds

Hi-Pot Test (1 min):	F1200 Series	F1299 Series
Line to Ground:	1500VAC	1500VAC
Line to Line:	1768VDC	1450VDC

Insulation Resistance: $9 \times 10^9 \Omega$ at 100VDC

Ambient Temperature: 40°C Max at rated current

Humidity Range: 0% to 95% R.H.

Termination:

A: QC – Quick Connect	C: IEC Receptacle
B: Wire	D: Screw

Maximum Leakage Current:

Each Line to Ground	F1200	F1250	F1299	F1260	F1270	F1280	F1299
115VAC, 60Hz:	0.40mA	0.25mA	.15mA	.25mA	.002mA	.015mA	.030mA
250VAC, 50Hz:	.75mA	.40mA	.25mA	.45mA	.005mA	.025mA	.050mA

Agency Approvals F1200:



Agency Approvals F1299:



F1200/F1250 Simplified Schematic

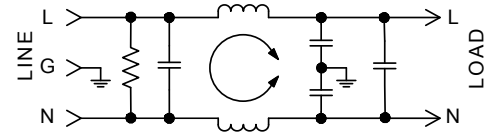

F1299 Simplified Schematic

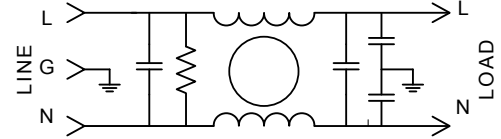

F1200AA/F1250AA (1, 3, 6, 10 and 20Amp) Dimensions

Amps	A	B	C	D	E	F
1A	2.750 (69,9)	2.00 (50,8)	.875 (22,2)	2.375 (60,3)	1.750 (44,5)	.550 (14,0)
3A	2.750 (69,9)	2.00 (50,8)	1.125 (28,5)	2.375 (60,3)	1.750 (44,5)	.550 (14,0)
6A	2.750 (69,9)	2.00 (50,8)	1.125 (28,5)	2.375 (60,3)	1.750 (44,5)	.550 (14,0)
10A	2.750 (69,9)	2.00 (50,8)	1.125 (28,5)	2.375 (60,3)	2.000 (50,8)	.550 (14,0)
20A	3.310 (84,1)	2.50 (63,5)	1.500 (38,1)	2.940 (74,7)	2.000 (50,8)	.550 (14,0)

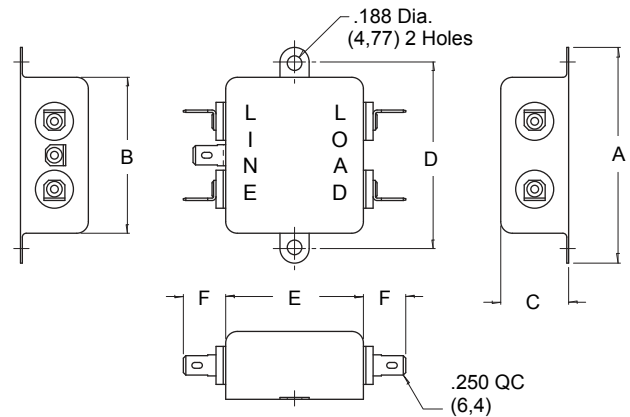

F1200BB/FB1250BB (1, 3, 6 and 10Amp) Dimensions

Amps	A	B	C	D	E
1A	2.750 (69,9)	2.00 (50,8)	.875 (22,2)	2.375 (60,3)	1.750 (44,5)
3A	2.750 (69,9)	2.00 (50,8)	1.125 (28,5)	2.375 (60,3)	1.750 (44,5)
6A	2.750 (69,9)	2.00 (50,8)	1.125 (28,5)	2.375 (60,3)	1.750 (44,5)
10A	2.750 (69,9)	2.00 (50,8)	1.125 (28,5)	2.375 (60,3)	2.000 (50,8)

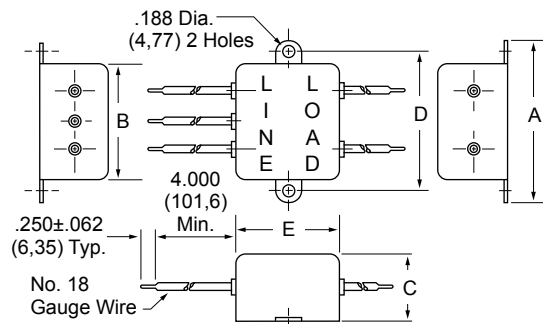

F1200CA/F1250CA (3, 6, and 10Amp) Dimensions

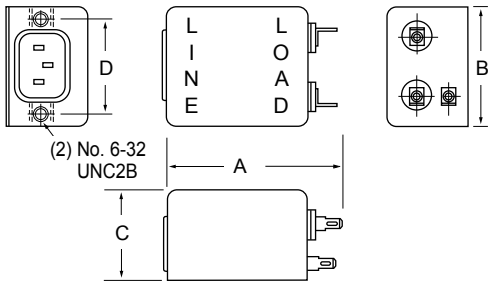

Amps	A	B	C	D
3A	2.55 (64,8)	2.000 (50,8)	1.50 (38,1)	1.575 (40,0)
6A	3.05 (77,5)	2.000 (50,8)	1.500 (38,1)	1.575 (40,0)
10A	3.05 (77,5)	2.000 (50,8)	1.500 (38,1)	1.575 (40,0)

Refer to Page 36 for Standard Mounting Cutouts

F1200DD/F1250DD (20Amp Only) Dimensions

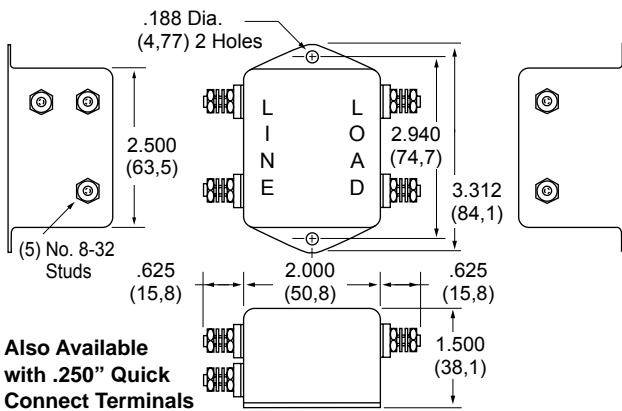

F1200DD30 (30Amp Only) Dimensions

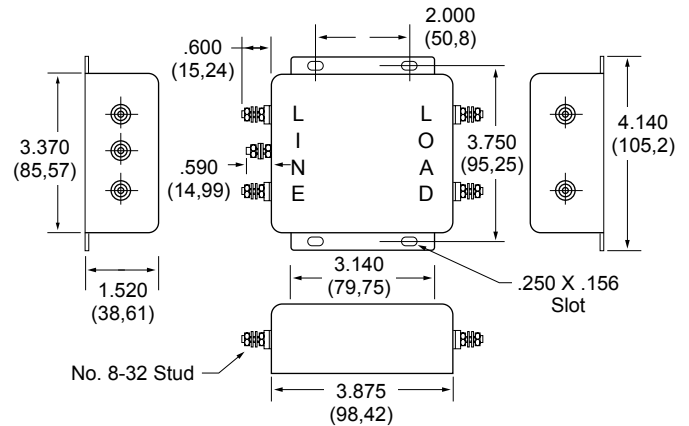

F1299AA (2, 3, 6, 10 and 20Amp) Dimensions

Amps	A	B	C	D	E
2A	2.81 (71,4)	2.07 (52,6)	0.91 (23,1)	2.375 (60,33)	3.10 (78,7)
3A	2.81 (71,4)	2.07 (52,6)	1.16 (29,5)	2.375 (60,33)	3.10 (78,7)
6A	2.81 (71,4)	2.07 (52,6)	1.16 (29,5)	2.375 (60,33)	3.10 (78,7)
10A	2.81 (71,4)	2.07 (52,6)	1.16 (29,5)	2.375 (60,33)	3.35 (85,1)
20A	3.35 (85,1)	2.56 (65,0)	1.53 (38,9)	2.938 (74,63)	3.35 (85,1)

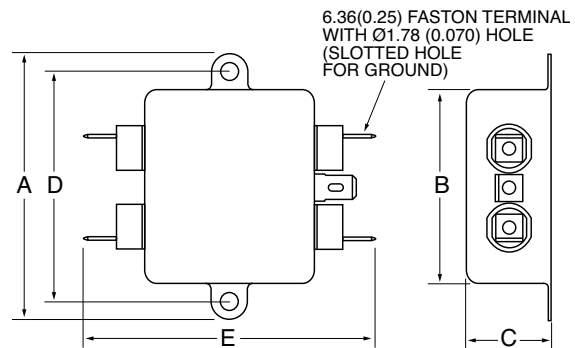

F1200/F1250/F1299 RFI Filters (continued)

General Purpose

SINGLE PHASE FILTERS

F1299BB (2, 3, 6 and 10Amp) Dimensions

Amps	A	B	C	D	E
2A	2.81 (71,4)	2.07 (52,6)	0.91 (23,1)	2.375 (60,33)	1.81 (46,0)
3A	2.81 (71,4)	2.07 (52,6)	1.16 (29,5)	2.375 (60,33)	3.10 (78,7)
6A	2.81 (71,4)	2.07 (52,6)	1.16 (29,5)	2.375 (60,33)	3.10 (78,7)
10A	2.81 (71,4)	2.07 (52,6)	1.16 (29,5)	2.375 (60,33)	2.07 (52,6)

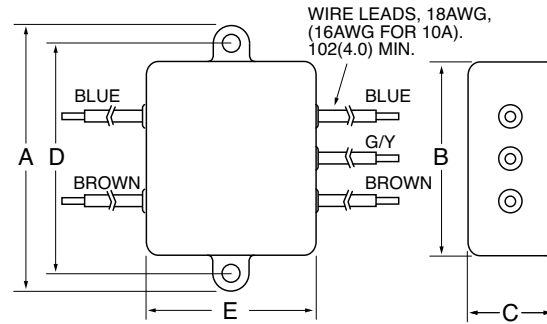

F1299CA (3, 6 and 10Amp) Dimensions

Amps	A	B	C	D
3A	3.21 (81,5)	2.25 (57,2)	1.28 (32,5)	1.575 (40,0)
6A	3.21 (81,5)	2.25 (57,2)	1.28 (32,5)	1.575 (40,0)
10A	3.71 (94,2)	2.25 (57,2)	1.28 (32,5)	1.575 (40,0)

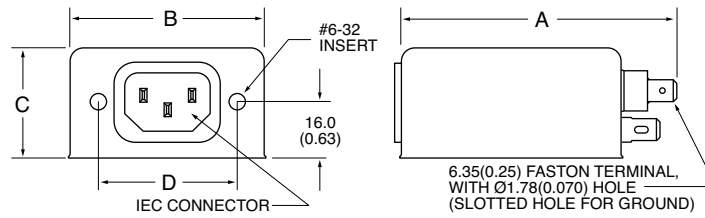

F1299DD (10, 20 and 30Amp) Dimensions

Amps	A	B	C	D	E
10A	2.81 (71,40)	2.07 (52,6)	1.16 (29,5)	2.375 (60,33)	3.46 (87,9)
20A	3.35 (85,1)	2.56 (65,0)	1.53 (38,9)	2.938 (74,63)	3.46 (87,9)
30A	4.20 (106,7)	3.38 (85,9)	1.53 (38,9)	3.750 (95,25)	5.34 (135,6)

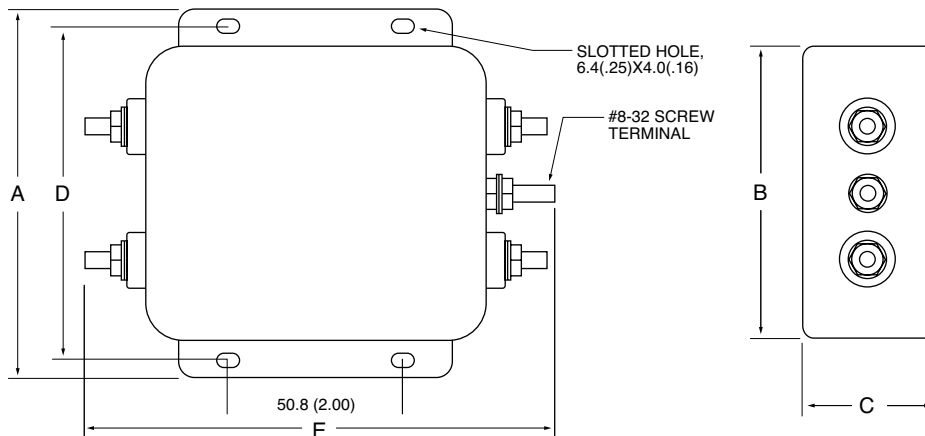
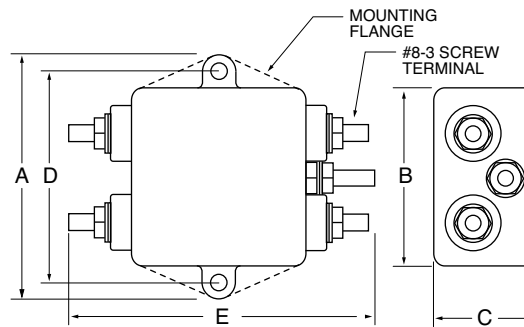

F1300/F1350/F1399 RFI Filters

Features:

- T Circuit Configuration—Designed for Motor, Capacitive and Other Low Impedance Loads
- Dual Coils — Higher Performance in Unknown RFI and Noise Susceptibility Applications
- Integral IEC Connector and PC Mounted Versions Now Available



Nominal Current Rating	Part Number	Termination Line/Load	MINIMUM INSERTION LOSS - dB (50 ohm Circuit)						
			MODE	Frequency - MHz					
				.15	.50	1.0	5.0	10	30
1A	F1300AA01	QC/QC	Common	40	65	65	65	65	65
	F1300BB01	Wire/Wire	Differential	2	57	69	70	70	60
	F1350AA01	QC/QC	Common	30	60	65	65	65	65
	F1350BB01	Wire/Wire	Differential	2	57	69	70	70	60
2A	F1399AA02	QC/QC	Common	40	65	65	65	65	40
	F1399BB02	Wire/Wire	Differential	5	45	70	65	60	50
3A	F1300AA03	QC/QC	Common	40	65	65	65	65	65
	F1300BB03	Wire/Wire		Differential	7	64	70	70	70
	F1300CA03	IEC/QC	Common	30	60	65	65	65	65
	F1300CP03	IEC/PC		Differential	7	64	70	70	70
	F1399AA03	QC/QC	Common	40	65	65	65	65	40
	F1399BB03	Wire/Wire		Differential	12	55	70	65	60
F1399CA03	IEC/QC								
6A	F1300AA06	QC/QC	Common	12	48	60	65	65	65
	F1300BB06	Wire/Wire		Differential	10	40	70	70	70
	F1300CA06	IEC/QC	Common	2	40	60	65	65	65
	F1350AA06	QC/QC		Differential	10	40	70	70	70
	F1350BB06	Wire/Wire	Common	30	55	65	65	65	40
	F1350CA06	IEC/QC		Differential	5	40	70	65	60
F1399AA06	QC/QC								
10A	F1300AA10	QC/QC	Common	12	48	60	65	65	65
	F1300BB10	Wire/Wire		Differential	13	13	64	70	67
	F1300CA10	IEC/QC	Common	2	40	60	65	65	65
	F1350AA10	QC/QC		Differential	13	13	64	70	67
	F1399AA10	QC/QC	Common	5	40	52	60	60	50
	F1399BB10	Wire/Wire		Differential	5	12	50	65	60
F1399CA10	IEC/QC								
F1399DD10	Screw/Screw								
15A	F1300AA15	QC/QC	Common	14	35	44	56	58	55
			Differential	15	10	45	70	67	56
20A	F1300AA20	QC/QC	Common	5	44	60	65	65	60
			Differential	—	—	35	60	57	45
	F1350AA20	QC/QC	Common	2	35	61	63	60	50
			Differential	—	—	35	60	57	45
F1399AA20	QC/QC	Common	5	40	52	60	60	52	
F1399DD20	Screw/Screw		Differential	5	12	50	65	60	55

NOTE: Other combinations of terminals may be specified on special order.

Dimensions are in inches and millimeters unless otherwise specified. Values in parentheses are metric equivalents.



Curtis Industries
A Division of Powers Holdings, Inc.

1-800-657-0853

General Purpose

SINGLE PHASE FILTERS

F1300/F1350/F1399 RFI Filters (continued)

Specifications:

Rated Voltage: 250VAC Maximum - 50/60 Hz

Rated Current:

115VAC	1A	2A	3A	6A	10A	15A	20A
250VAC	1A	1.5A	2.5A	4A	6A	15A	16A

Current Overload: 6X for 8 seconds

Hi-Pot Test (1 min): **F1300/F1350**

Line to Ground: 1500VAC
Line to Line: 1768VDC

Insulation Resistance: $9 \times 10^9 \Omega$ at 100VDC

Ambient Temperature: 40°C Max. at rated current

Humidity Range: 0% to 95% R.H.

Termination: A: QC – Quick Connect C: IEC Receptacle
B: Wire P: PC – P.C. Board

Maximum Leakage Current: Each Line to Ground

	F1300	F1350	D1399	F1360	F1370	F1380	F1390
115VAC, 60Hz:	0.4mA	0.25mA	0.25mA	.15mA	.002mA	.015mA	.030mA
250VAC, 50Hz:	.75mA	.40mA	0.45mA	.25mA	.005mA	.025mA	.050mA

Agency Approvals:



General Purpose

SINGLE PHASE FILTERS

F1300AA (1, 3, 6, 10 and 15Amp) F1350AA (1, 3, 6 and 10Amp) Dimensions

Amps	A	B	C	D	E
1A	2.750 (69,9)	1.750 (44,5)	1.125 (28,5)	2.375 (60,3)	2.925 (74,3)
3A	3.312 (84,1)	2.000 (50,8)	1.125 (28,5)	2.940 (74,7)	3.49 (88,7)
6A	3.312 (84,1)	2.000 (50,8)	1.125 (28,5)	2.940 (74,7)	3.49 (88,7)
10A	3.312 (84,1)	2.000 (50,8)	1.500 (38,1)	2.940 (74,7)	3.49 (88,7)
15A	3.312 (84,1)	2.000 (50,8)	1.500 (38,1)	2.940 (74,7)	3.49 (88,7)

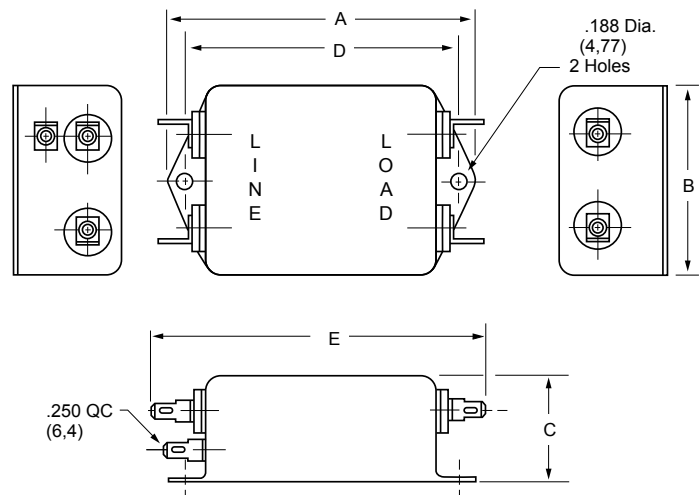

F1300BB/F1350BB (1, 3, 6 and 10Amp) Dimensions

Amps	A	B	C	D	E
1A	2.750 (69,9)	1.750 (44,5)	1.125 (28,5)	2.375 (60,3)	2.000 (50,8)
3A	3.312 (84,1)	2.000 (50,8)	1.125 (28,5)	2.940 (74,7)	2.500 (63,5)
6A	3.312 (84,1)	2.000 (50,8)	1.125 (28,5)	2.940 (74,7)	2.500 (63,5)
10A	3.312 (84,1)	2.000 (50,8)	1.500 (38,1)	2.940 (74,7)	2.500 (63,5)

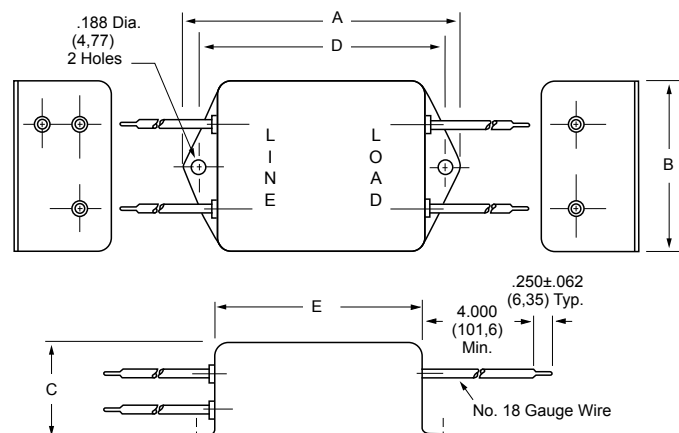

F1300/F1350 Simplified Schematic

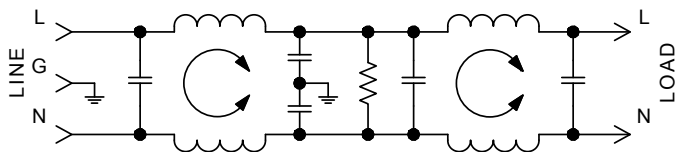

F1300CA (3, 6 and 10Amp) F1350CA (3 and 6Amp) Dimensions

Refer to Page 40
for Standard
Mounting Cutouts

Amps	A	B	C	D	E
3A	2.500 (63,6)	2.000 (50,8)	1.500 (38,1)	.550 (14,0)	.565 (14,3)
6A	2.500 (63,5)	2.000 (50,8)	1.500 (38,1)	.550 (14,0)	.565 (14,3)
10A	2.880 (73,1)	2.120 (53,8)	1.500 (38,1)	.65 (16,0)	.565 (14,3)

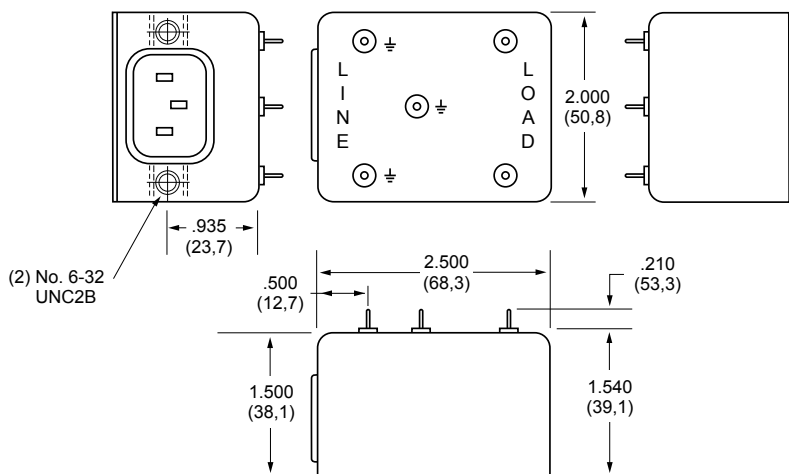
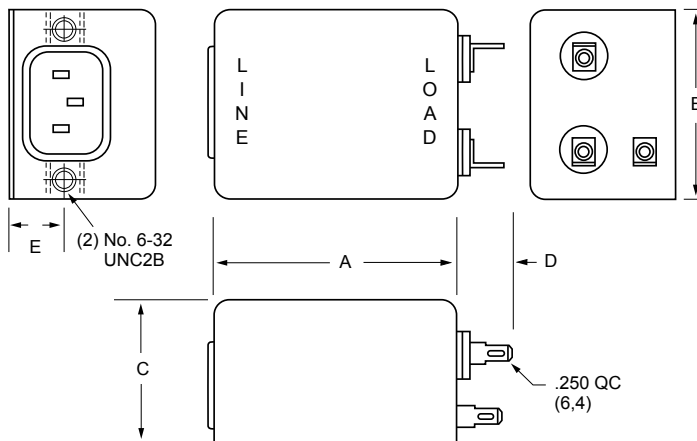

F1300CP/F1350CP (3Amp Only) Dimensions

Refer to Page 40
for Standard
Mounting Cutouts

F1300AA/F1350AA (20Amp Only) Dimensions

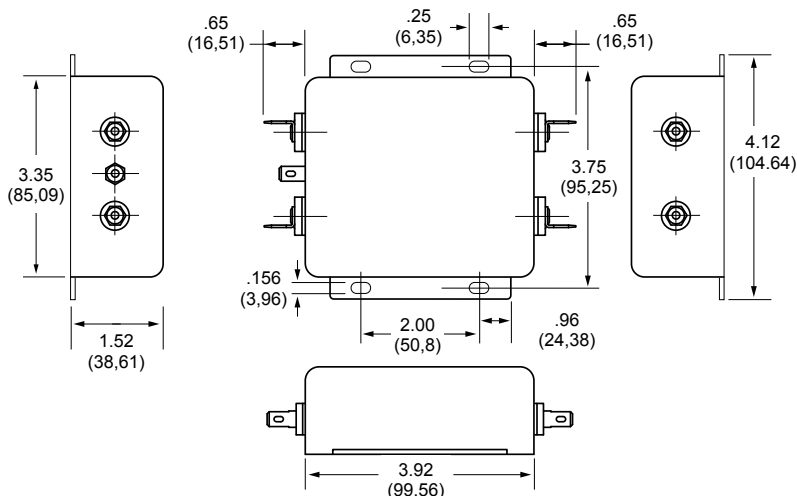

Dimensions are in inches and millimeters
unless otherwise specified.
Values in parentheses are metric equivalents.



F1300/F1399 RFI Filters (continued)

General Purpose

SINGLE PHASE FILTERS

F1399 Simplified Schematic

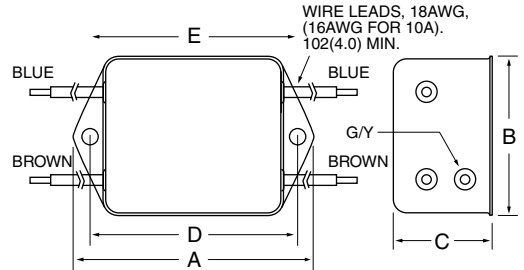
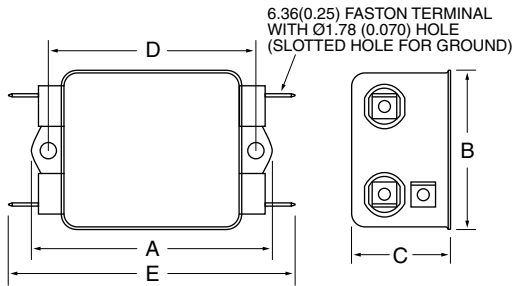
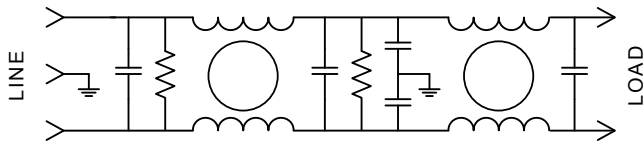

F1399BB (2, 3, 6 and 10Amp) Dimensions

Amps	A	B	C	D	E
2A	2.07 (52,6)	1.81 (46,0)	1.16 (29,5)	2.375 (60,33)	2.78 (70,6)
3A	2.56 (65,0)	2.07 (52,6)	1.16 (29,5)	2.938 (74,63)	3.35 (85,1)
6A	2.56 (65,0)	2.07 (52,6)	1.16 (29,5)	2.938 (74,63)	3.35 (85,1)
10A	2.56 (65,0)	2.07 (52,6)	1.53 (38,9)	2.938 (74,63)	3.35 (85,1)

F1399AA (2, 3, 6, 10 and 20Amp) Dimensions

Amps	A	B	C	D	E
2A	3.35 (85,1)	1.81 (46,0)	1.16 (29,5)	2.375 (60,33)	2.78 (70,6)
3A	3.85 (97,8)	2.07 (52,6)	1.16 (29,5)	2.938 (74,63)	3.35 (85,1)
6A	3.85 (97,8)	2.07 (52,6)	1.16 (29,5)	2.938 (74,63)	3.35 (85,1)
10A	3.85 (97,8)	2.07 (52,6)	1.53 (38,9)	2.938 (74,63)	3.35 (85,1)
20A	5.23 (132,8)	3.37 (85,6)	1.53 (38,9)	3.75 (95,25)	4.20 (106,7)

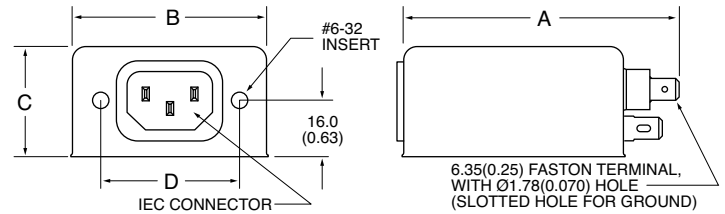

F1399CA (3, 6 and 10Amp) Dimensions

Amps	A	B	C	D
3A	4.33 (110,0)	2.25 (57,2)	1.28 (32,5)	1.575 (40,0)
6A	4.33 (110,0)	2.25 (57,2)	1.28 (32,5)	1.575 (40,0)
10A	4.33 (110,0)	2.25 (57,2)	1.53 (38,9)	1.575 (40,0)

F1399DD (10 and 20Amp) Dimensions

Amps	A	B	C	D	E
10A	3.96 (100,6)	2.07 (52,6)	1.53 (38,9)	2.938 (74,63)	3.35 (85,1)
20A	5.34 (135,6)	3.37 (85,6)	1.53 (38,9)	3.75 (95,25)	4.20 (106,7)

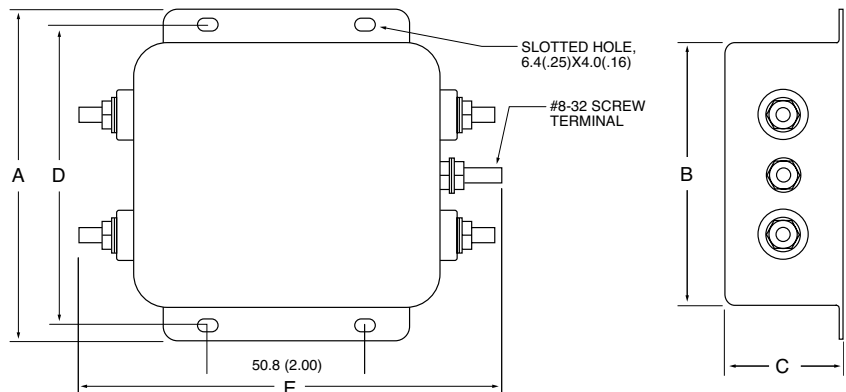
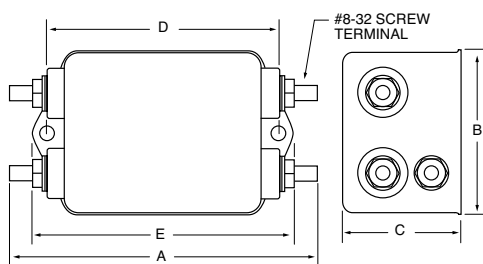

F1900 RFI Filters

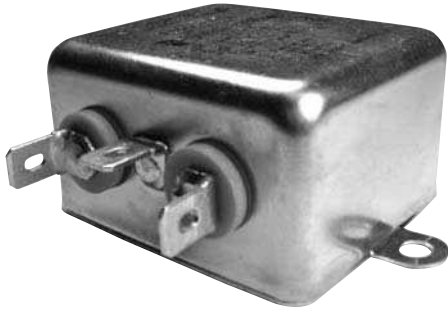

Features:

- Designed for Equipment Requiring UL1410 Approval (Consumer Electronics)
- Utilizes UL1414 Approved Components
- Greater Differential Mode Protection

F1900 Simplified Schematic

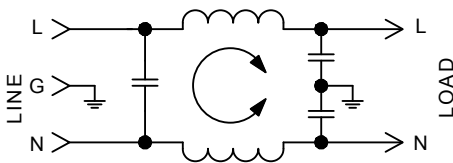

F1900AA

(3 and 6Amp) Dimensions

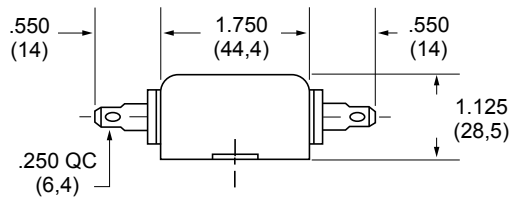
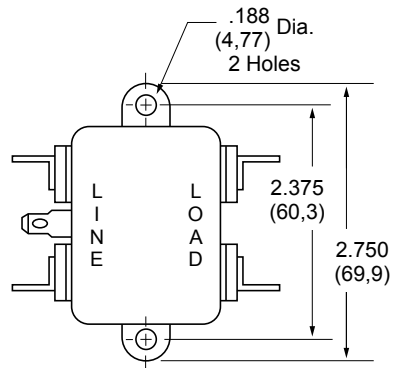
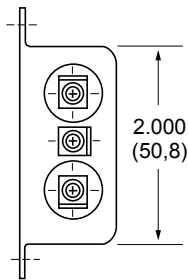

Specifications:

Rated Voltage: 125VAC Maximum - 50/60 Hz

Rated Current: 120VAC
3A
6A

Current Overload: 6X for 8 seconds

Hi-Pot Test (1 min):

Line to Ground 1500VAC

Line to Line 1768VDC

Insulation Resistance: $9 \times 10^9 \Omega$ at 100VDC

Ambient Temperature: 40°C Max. at rated current

Humidity Range: 0% to 95% R.H.

Termination:

A: QC – Quick Connect

Maximum Leakage Current:

Each Line to Ground **F1900**
115VAC, 60Hz: 0.25mA

Agency Approvals:



General Purpose

SINGLE PHASE FILTERS

Nominal Current Rating	Part Number	Termination Line/Load	MINIMUM INSERTION LOSS - dB (50 ohm Circuit)						
			MODE	Frequency - MHz					
				.15	.50	1.0	5.0	10	30
3A	F1900AA03	QC/QC	Common	20	30	37	50	50	50
			Differential	7	19	28	50	57	70
6A	F1900AA06	QC/QC	Common	10	20	27	45	45	45
			Differential	8	18	24	45	52	64

NOTE: Other combinations of terminals may be specified on special order.

Dimensions are in inches and millimeters unless otherwise specified. Values in parentheses are metric equivalents.



Curtis Industries
A Division of Powers Holdings, Inc.

1-800-657-0853

15

F1400 RFI Filters

High Performance

SINGLE PHASE FILTERS



Features:

- High Peak Current Design — High Insertion Loss for Switching Power Supply Emissions
- Low-Leakage Current
- Compact Case Sizes in 6 and 10Amp Models
- Available with Integral IEC Connector in 3 and 6Amp Models

F1400 Simplified Schematic

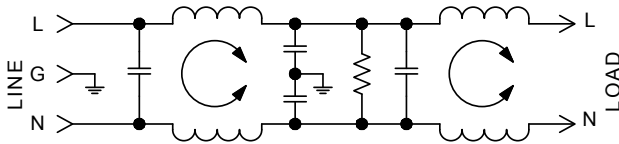

Specifications:

Rated Voltage: 250VAC Maximum - 50/60 Hz

Rated Current:

115VAC	250VAC
3A	1.5A
6A	4A
10A	6A

Current Overload: 6X for 8 seconds

Hi-Pot Test (1 min):

Line to Ground	1500VAC
Line to Line	1768VDC

Insulation Resistance: $9 \times 10^9 \Omega$ at 100VDC

Ambient Temperature: 40°C Max. at rated current

Humidity Range: 0% to 95% R.H.

Termination:

- A: QC – Quick Connect
- B: Wire
- C: IEC Receptacle

Maximum Leakage Current:

Each Line to Ground	F1400
115VAC, 60Hz:	0.25mA
250VAC, 50Hz:	0.40mA

Agency Approvals:



Nominal Current Rating	Part Number	Termination Line/Load	MINIMUM INSERTION LOSS - dB (50 ohm Circuit)						
			MODE	Frequency - MHz					
				.15	.50	1.0	5.0	10	30
3A	F1400AA03 F1400BB03 F1400CA03	QC/QC Wire/Wire IEC/QC	Common	58	65	65	65	60	44
			Differential	40	60	65	65	65	60
6A	F1400AA06 F1400BB06 F1400CA06	QC/QC Wire/Wire IEC/QC	Common	58	65	65	65	60	54
			Differential	36	55	60	60	55	50
10A	F1400AA10 F1400BB10	QC/QC Wire/Wire	Common	56	65	65	65	60	54
			Differential	40	50	60	65	65	60

NOTE: Other combinations of terminals may be specified on special order.



F1400AA (3, 6 and 10Amp) Dimensions

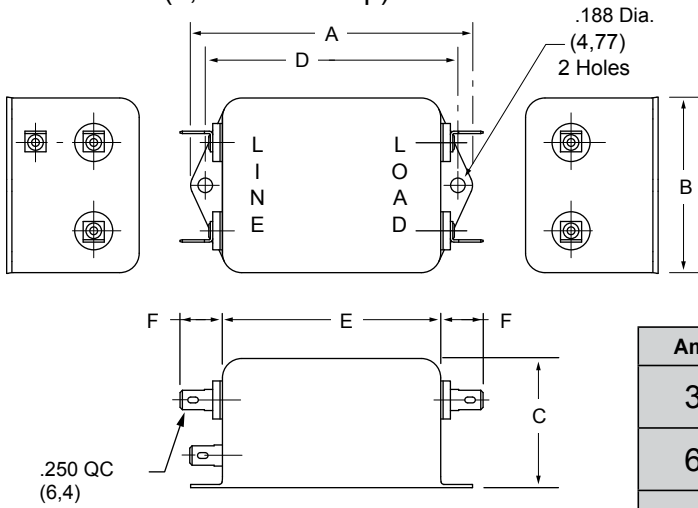

Amps	A	B	C	D	E	F
3A	3.310 (84,1)	2.000 (50,8)	1.500 (38,2)	2.940 (74,7)	2.500 (63,5)	.550 (14,0)
6A	3.310 (84,1)	2.000 (50,8)	1.500 (38,2)	2.940 (74,7)	2.500 (63,5)	.550 (14,0)
10A	4.70 (119,4)	2.250 (57,1)	1.750 (44,4)	4.250 (107,9)	3.750 (95,3)	.550 (14,0)

F1400BB (3, 6 and 10Amp) Dimensions

Amps	A	B	C	D	E
3A	3.310 (84,1)	2.000 (50,8)	1.500 (38,1)	2.940 (74,7)	2.500 (63,5)
6A	3.310 (84,1)	2.000 (50,8)	1.500 (38,1)	2.940 (74,7)	2.500 (63,5)
10A	4.70 (119,4)	2.250 (57,1)	1.750 (44,4)	4.250 (107,9)	3.750 (95,3)

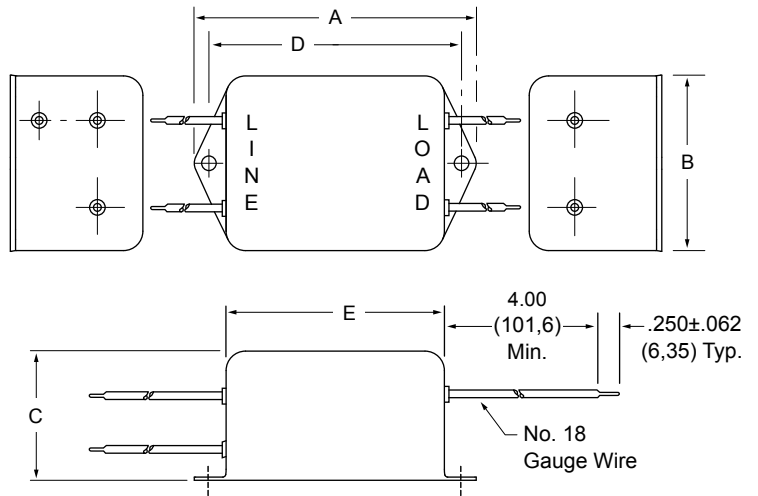

F1400CA (3 and 6Amp) Dimensions

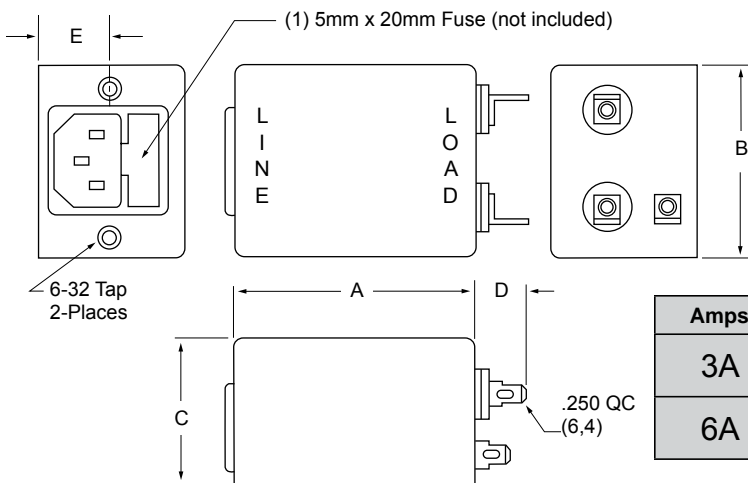

Refer to Page 40
for Standard
Mounting Cutouts

Amps	A	B	C	D	E
3A	2.880 (73,1)	2.120 (53,8)	1.500 (38,1)	.550 (14,0)	.565 (14,3)
6A	2.880 (73,1)	2.120 (53,8)	1.500 (38,1)	.550 (14,0)	.565 (14,3)



F1500 RFI Filters

High Performance

SINGLE PHASE FILTERS



Features:

- IEC Connector Plus Common and Differential Mode Performance in Compact Case
- “L” Circuit Configuration — Cost-Effective in Many Linear and Switching Power Supply Applications
- High-Inductance Design for Greater Attenuation
- Available with 0.250" Quick Connect Terminals or Wire Leads on the Load Side

F1500AX/F1500CX Simplified Schematic

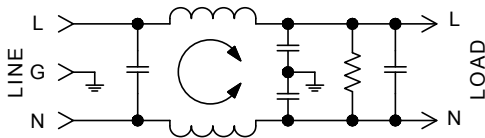

Specifications:

Rated Voltage: 250VAC Maximum - 50/60 Hz

Rated Current:	115VAC	250VAC
	3A	1.5A
	6A	3A
	10A	6A
	15A	8A

Current Overload: 6X for 8 seconds

Hi-Pot Test (1 min):

Line to Ground	1500VAC
Line to Line	1768VDC

Insulation Resistance: $9 \times 10^9 \Omega$ at 100VDC

Ambient Temperature: 40°C Max. at rated current

Humidity Range: 0% to 95% R.H.

Termination:

- A: QC – Quick Connect
- B: Wire
- C: IEC Receptacle
- F: IEC Receptacle with Fuse Holder

Maximum Leakage Current:

Each Line to Ground	F1500
115VAC, 60Hz:	0.25mA
250VAC, 50Hz:	0.40mA

Agency Approvals:



F1500FX Simplified Schematic

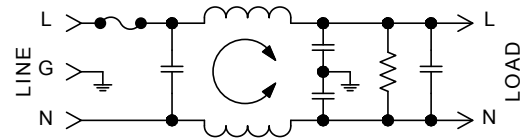

Nominal Current Rating	Part Number	Termination Line/Load	MINIMUM INSERTION LOSS - dB (50 ohm Circuit)						
			MODE	Frequency - MHz					
				.15	.50	1.0	5.0	10	30
3A	F1500AA03	QC/QC	Common Differential	32 35	43 60	50 65	50 60	50 55	50 40
	F1500CA03	IEC/QC							
	F1500FA03	Fused IEC/QC							
	F1500CB03	QC/Wire							
6A	F1500AA06	IEC/QC	Common Differential	32 30	42 60	45 65	45 65	45 60	45 50
	F1500CA06	Fused IEC/QC							
	F1500FA06	QC/Wire							
	F1500CB06								
10A	F1500AA10	QC/QC	Common Differential	29 15	36 50	39 65	45 65	45 60	45 50
	F1500CA10	IEC/QC							
	F1500FA10	Fused IEC/QC							
	F1500CB10								
15A	F1500CA15	IEC/QC	Common Differential	26 35	32 60	36 65	44 65	46 65	52 65
	F1500CB15	IEC/Wire							

NOTE: Other combinations of terminals may be specified on special order.



F1500AA (3 and 10Amp) Dimensions

Refer to Page 40
for Standard
Mounting Cutouts

Amps	A	B	C	D	E
3A	3.31 (84,1)	2.000 (50,8)	1.13 (28,7)	2.938 (74,6)	2.50 (63,5)
10A	3.31 (84,1)	2.000 (50,8)	1.50 (38,1)	2.938 (74,6)	2.50 (63,5)

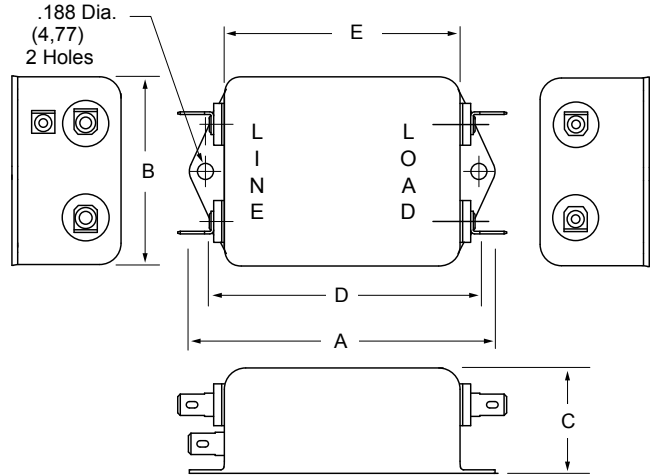

F1500CA (3, 6, 10 and 15Amp) Dimensions

F1500CB (3, 6, 10 and 15Amp) Dimensions

Refer to Page 40
for Standard
Mounting Cutouts

Amps	A	B	C	D	E
3A	2.000 (50,8)	2.000 (50,8)	1.500 (38,1)	.550 (14,0)	.565 (14,3)
6A	2.500 (63,5)	2.000 (50,8)	1.500 (38,1)	.550 (14,0)	.565 (14,3)
10A	2.500 (63,5)	2.000 (50,8)	1.500 (38,1)	.550 (14,0)	.565 (14,3)
15A	3.25 (82,6)	2.25 (57,2)	1.75 (44,5)	.550 (14,0)	.705 (17,9)

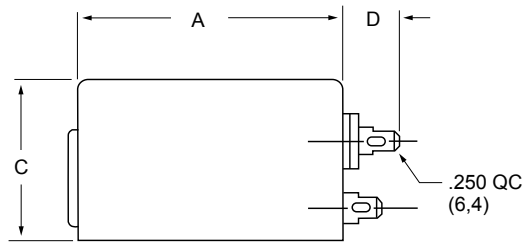
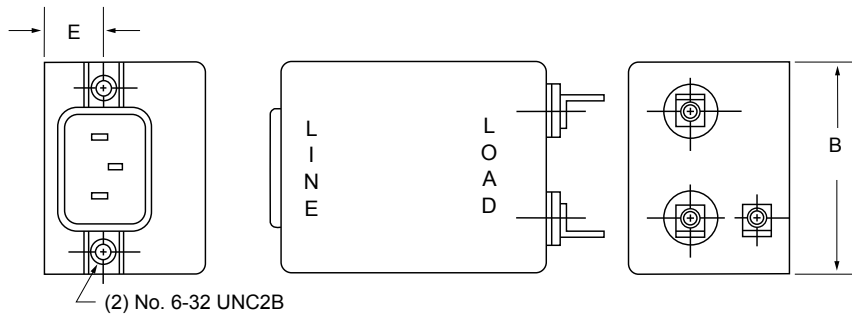

F1500FA (3, 6 and 10Amp) Dimensions

Refer to Page 40
for Standard
Mounting Cutouts

Amps	A	B	C	D	E
3A	2.000 (50,8)	2.000 (50,8)	1.500 (38,1)	.550 (14,0)	.752 (19,1)
6A	2.500 (63,5)	2.000 (50,8)	1.500 (38,1)	.550 (14,0)	.752 (19,1)
10A	2.500 (63,5)	2.000 (50,8)	1.500 (38,1)	.550 (14,0)	.752 (19,1)

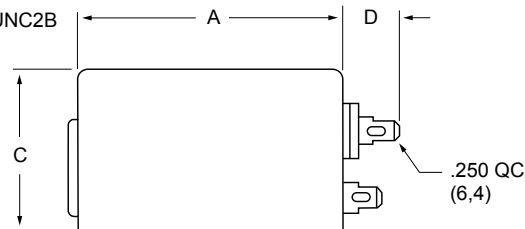
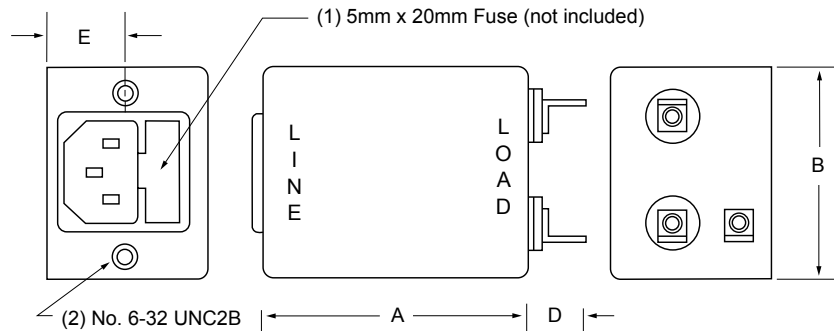

F1600 RFI Filters

High Performance

SINGLE PHASE FILTERS



Features:

- T Section, Dual Coil Design – High Insertion Loss for Switching Power Supply Emissions
- Low-Leakage Current Design
- Space-Efficient with Integral IEC Connector and Compact Case in Current Ratings up to 10Amps
- Available in Fused IEC Connector and PC Mounted Versions

F1600CX Simplified Schematic

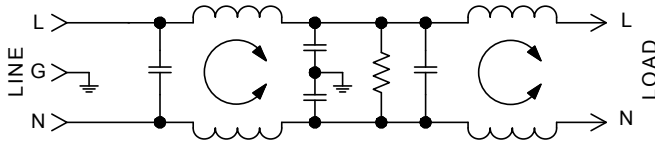

F1600FA Simplified Schematic

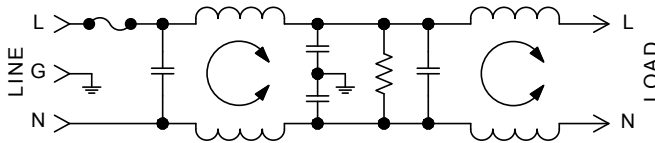

Specifications:

Rated Voltage: 250VAC Maximum - 50/60 Hz

Rated Current:

115VAC	250VAC
3A	1.5A
6A	3A
10A	6A

Current Overload: 6X for 8 seconds

Hi-Pot Test (1 min):

Line to Ground	1500VAC
Line to Line	1768VDC

Insulation Resistance: $9 \times 10^9 \Omega$ at 100VDC

Ambient Temperature: 40°C Max. at rated current

Humidity Range: 0% to 95% R.H.

Termination:

- A: QC – Quick Connect
- B: Wire
- C: IEC Receptacle
- P: PC – P.C. Board

Maximum Leakage Current:

Each Line to Ground	F1600
115VAC, 60Hz:	0.25mA
250VAC, 50Hz:	0.40mA

Agency Approvals:



Nominal Current Rating	Part Number	Termination Line/Load	MINIMUM INSERTION LOSS - dB (50 ohm Circuit)						
			MODE	Frequency - MHz					
				.15	.50	1.0	5.0	10	30
3A	F1600CA03 F1600CP03 F1600FA03 F1600CB03	IEC/QC IEC/PC Fused IEC/QC IEC/Wire	Common	52	65	65	65	65	65
			Differential	40	50	60	65	65	50
6A	F1600CA06 F1600CP06 F1600FA06 F1600CB06	IEC/QC IEC/PC Fused IEC/QC IEC/Wire	Common	45	65	65	65	65	59
			Differential	30	45	55	50	50	50
10A	F1600CA10 F1600CB10	IEC/QC IEC/Wire	Common	50	65	65	65	65	54
			Differential	23	45	55	50	50	50

NOTE: Other combinations of terminals may be specified on special order.



F1600CA (3, 6 and 10Amp) Dimensions **F1600CB** (3, 6 and 10Amp) Dimensions

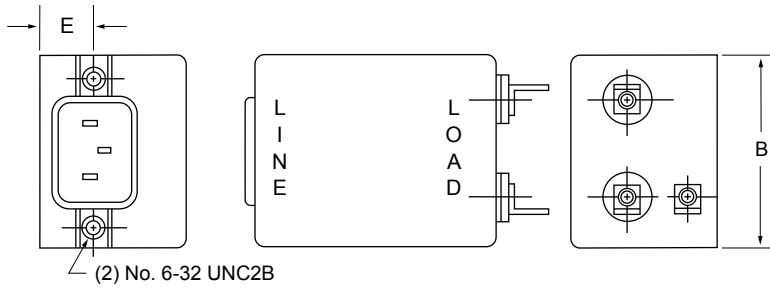

Refer to Page 40
for Standard
Mounting Cutouts

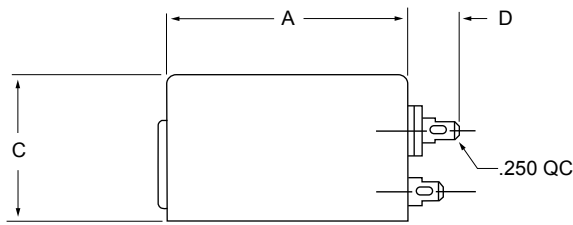

Amps	A	B	C	D	E
3A	2.500 (63,5)	2.000 (50,8)	1.500 (38,2)	.550 (14,0)	.565 (14,3)
6A	2.500 (63,5)	2.000 (50,8)	1.500 (38,2)	.550 (14,0)	.565 (14,3)
10A	3.750 (95,2)	2.250 (57,2)	1.750 (44,5)	.550 (14,0)	.640 (16,3)

F1600CP
(3 and 6Amp)
Dimensions

Refer to Page 40
for Standard
Mounting Cutouts

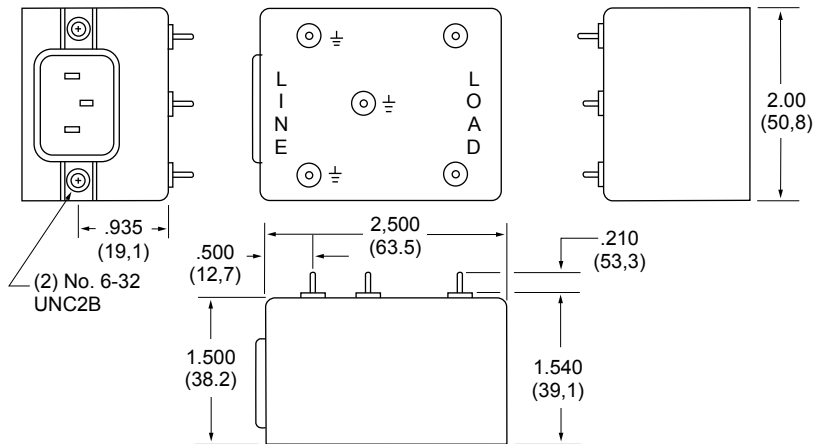

F1600FA
(3 and 6Amp)
Dimensions

Refer to Page 40
for Standard
Mounting Cutouts

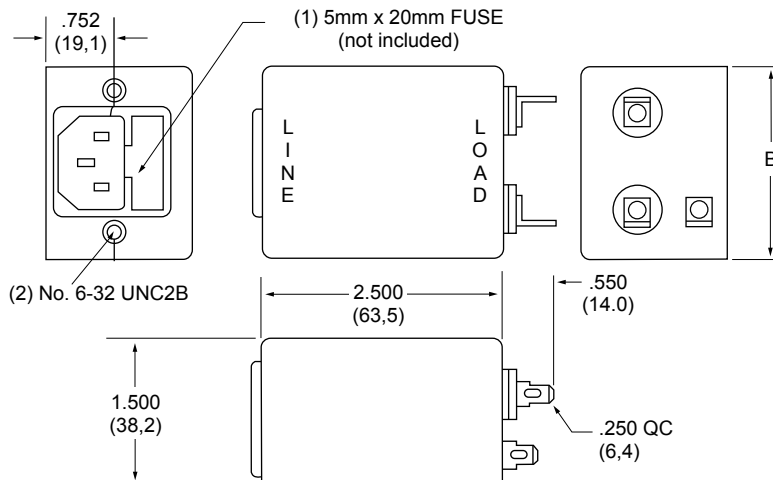

F1700/F1799 RFI Filters

High Performance

Features:

- General Purpose — Designed for Applications with Higher Differential Mode Noise
- Higher Line-to-Line Capacitance for Protection from Pulsed, Intermittent or Continuous RFI
- A Cost-Effective Replacement for Independent Coil Design in Many SMPS Applications
- Available with Integral IEC Connector



Specifications:

Rated Voltage: 250VAC Maximum - 50/60 Hz

Rated Current:	115VAC	250VAC
	3A	2.5A
	6A	4A
	10A	6A
	20A	10A
	30A	15A

Current Overload: 6X for 8 seconds

Hi-Pot Test (1 min):

Line to Ground	1500VAC
Line to Line	1768VDC

Insulation Resistance: $9 \times 10^9 \Omega$ at 100VDC

Ambient Temperature: 40°C Max. at rated current

Humidity Range: 0% to 95% R.H.

Termination:

A: QC – Quick Connect	C: IEC Receptacle
B: Wire	D: Screw

Maximum Leakage Current:

Each Line to Ground	F1700	F1710	F1720	F1740	F1799
115VAC, 60Hz:	0.40mA	.15mA	.002mA	.060mA	0.25mA
250VAC, 50Hz:	0.75mA	.25mA	.005mA	.120mA	0.45mA

Agency Approvals:



F1700 Simplified Schematic

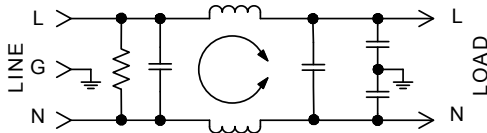

F1799 Simplified Schematic

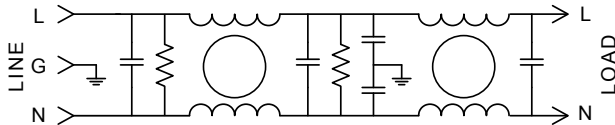

SINGLE PHASE FILTERS

Nominal Current Rating	Part Number	Termination Line/Load	MINIMUM INSERTION LOSS - dB (50 ohm Circuit)						
			MODE	.15	.50	1.0	5.0	10	30
3A	F1700AA03	QC/QC	Common	20	35	43	52	55	50
	F1700BB03	Wire/Wire	Differential	25	60	65	65	50	50
	F1700CA03	IEC/QC							
	F1710AA03	QC/QC	Common	20	34	40	45	45	40
6A	F1720AA03	QC/QC	Differential	35	60	65	60	55	40
	F1740AA03	QC/QC	Common	20	30	35	35	35	40
			Differential	35	60	65	60	55	40
	F1700AA06	QC/QC	Common	10	22	30	46	50	45
10A	F1700BB06	Wire/Wire	Differential	15	50	65	60	60	60
	F1700CA06	IEC/QC							
	F1700AA10	QC/QC	Common	10	22	30	46	50	45
	F1700BB10	Wire/Wire	Differential	20	45	60	65	60	55
20A	F1700CA10	IEC/QC							
	F1700AA20	QC/QC	Common	10	22	30	42	47	40
	F1700DD20	Screw/Screw	Differential	15	45	60	65	60	55
	F1720DD20	Screw/Screw	Common	10	22	30	42	47	52
30A	F1700DD20	Screw/Screw	Differential	15	45	60	65	60	55
	F1700DD30	Screw/Screw	Common	7	15	20	34	42	40
			Differential	15	45	60	65	60	55
	F1799DD30	Screw/Screw	Common	10	45	55	60	60	50
			Differential	15	65	65	65	60	55

NOTE: Other combinations of terminals may be specified on special order.



F1700AA, 1710, 1720, 1740 (3, 6 and 10Amp) Dimensions

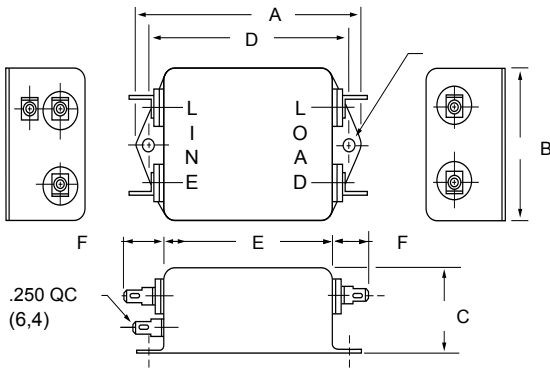

Amps	A	B	C	D	E	F
3A	2.750 (69,8)	1.750 (44,4)	1.125 (28,5)	2.375 (60,3)	2.000 (50,8)	.550 (14,0)
6A	3.312 (84,1)	2.000 (50,8)	1.125 (28,5)	2.940 (74,7)	2.500 (63,5)	.550 (14,0)
10A	3.312 (84,1)	2.000 (50,8)	1.500 (38,2)	2.940 (74,7)	2.500 (63,5)	.550 (14,0)
20A	See 1700DD20 for Case Dimensions					

F1700BB (3, 6 and 10Amp) Dimensions

Amps	A	B	C	D	E
3A	2.750 (69,8)	1.750 (44,4)	1.125 (28,5)	2.375 (60,3)	2.000 (50,8)
6A	3.312 (84,1)	2.000 (50,8)	1.125 (28,5)	2.940 (74,7)	2.500 (63,5)
10A	3.312 (84,1)	2.000 (50,8)	1.500 (38,1)	2.940 (74,7)	2.500 (63,5)

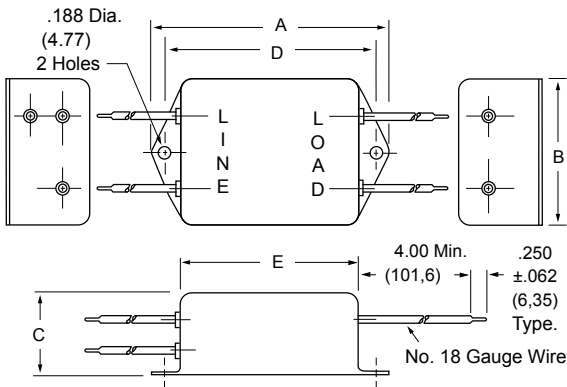

F1700CA (3, 6 and 10Amp) Dimensions

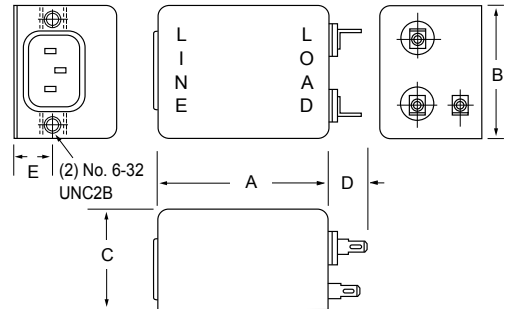

Refer to Page 40 for Standard Mounting Cutouts

Amps	A	B	C	D	E
3A	2.000 (50,8)	2.000 (50,8)	1.500 (38,1)	.550 (14,0)	.565 (14,3)
6A	2.500 (63,5)	2.000 (50,8)	1.500 (38,1)	.550 (14,0)	.565 (14,3)
10A	2.500 (63,5)	2.000 (50,8)	1.500 (38,1)	.550 (14,0)	.565 (14,3)

F1700DD20 (20Amp) Dimensions

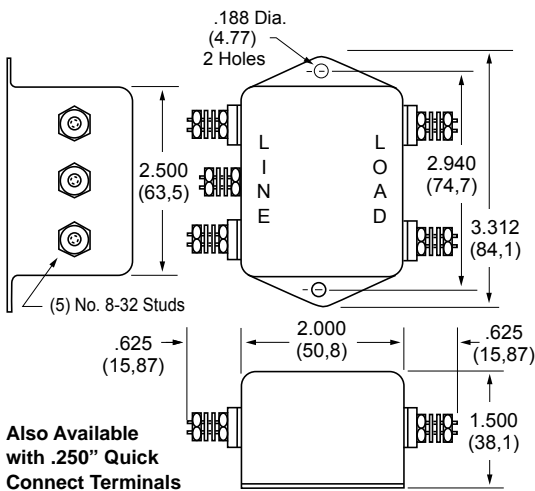

Also Available with .250" Quick Connect Terminals

F1700DD30 (30Amp) Dimensions

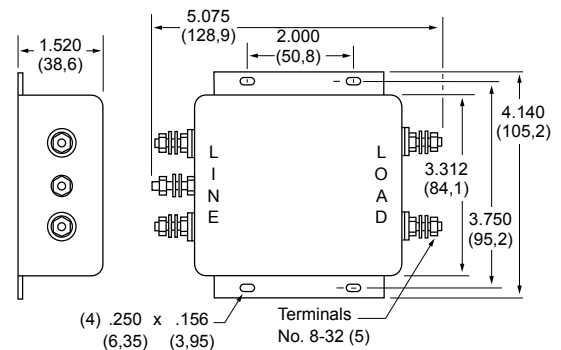

F1799DD (30Amp) Dimensions

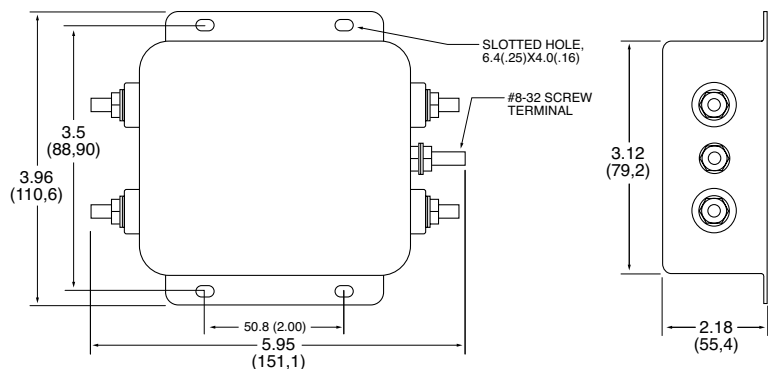

Dimensions are in inches and millimeters unless otherwise specified. Values in parentheses are metric equivalents.



F1760/F1770/F1780 RFI Filters

High Performance

SINGLE PHASE FILTERS



Features:

- Designed for Applications Where Switching Power Supplies, SCR's and TTL Circuits Are Utilized
- Protection from Pulsed, Intermittent or Continuous RFI
- Effective CM and DM Suppression for Most FCC VDE Requirements Down to 150KHz
- Available in Stud and Quick Connect Terminal Versions

Specifications:

Rated Voltage: 250VAC, Maximum - 50/60 Hz

Rated Current: 115VAC 250VAC
20A 14A

Current Overload: 6X for 8 seconds

Hi-Pot Test (1 min):

Line to Ground 1500VAC
Line to Line 1768VDC

Insulation Resistance: $9 \times 10^9 \Omega$ at 100VDC

Ambient Temperature: 40°C Max. at rated current

Humidity Range: 0% to 95% R.H.

Termination:

A: QC – Quick Connect
D: Screw

Maximum Leakage Current:

Each Line to Ground **F1760/1770/1780**
115VAC, 60Hz: 0.5mA
250VAC, 50Hz: 1.0mA

Agency Approvals:



F1760 Simplified Schematic

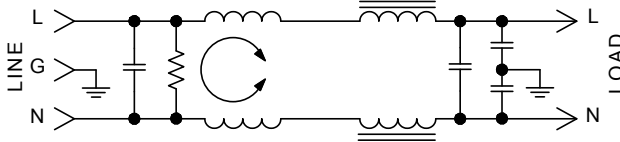

F1770 Simplified Schematic

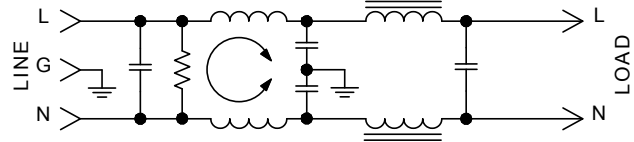

Nominal Current Rating	Part Number	Termination Line/Load	MINIMUM INSERTION LOSS - dB (50 ohm Circuit)								
			MODE	Frequency - MHz						20	30
				.15	.50	1.0	5.0	10			
3A	F1760AA03	QC/QC	Common	15	30	40	45	50	45	45	
	F1760DD03	Screw/Screw	Differential	40	65	65	60	55	55	55	
3A	F1780AA03	QC/QC	Common	13	25	40	60	60	55	50	
	F1780DD03	Screw/Screw	Differential	40	65	65	62	55	45	45	
6A	F1760AA06	QC/QC	Common	15	30	35	35	44	43	42	
	F1760DD06	Screw/Screw	Differential	40	65	65	65	53	52	50	
6A	F1780AA06	QC/QC	Common	13	30	40	65	65	53	48	
	F1780DD06	Screw/Screw	Differential	40	65	65	62	55	45	45	
10A	F1760AA10	QC/QC	Common	15	30	35	50	50	40	40	
	F1760DD10	Screw/Screw	Differential	40	65	65	55	50	50	50	
10A	F1780AA10	QC/QC	Common	13	20	35	65	65	55	50	
	F1780DD10	Screw/Screw	Differential	40	65	65	62	55	45	45	
20A	F1760AA20	QC/QC	Common	12	25	31	42	47	50	40	
	F1760DD20	Screw/Screw	Differential	41	65	65	65	60	60	55	
20A	F1780AA20	QC/QC	Common	12	30	32	60	60	60	55	
	F1780DD20	Screw/Screw	Differential	41	65	65	65	60	60	55	



F1780 Simplified Schematic

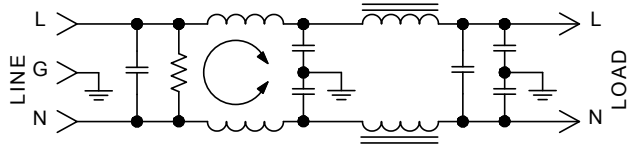

Amps	A	B	C	D	E	F
3A	2.750 (69,8)	1.750 (44,4)	1.125 (28,5)	2.375 (60,3)	2.000 (50,8)	.550 (14,0)
6A	3.312 (84,1)	2.000 (50,8)	1.500 (38,2)	2.940 (74,7)	2.500 (63,5)	.550 (14,0)
10A	3.312 (84,1)	2.000 (50,8)	1.500 (38,2)	2.940 (74,7)	2.500 (63,5)	.550 (14,0)

F1760/F1770/1780AA
(3, 6, and 10Amp) Dimensions

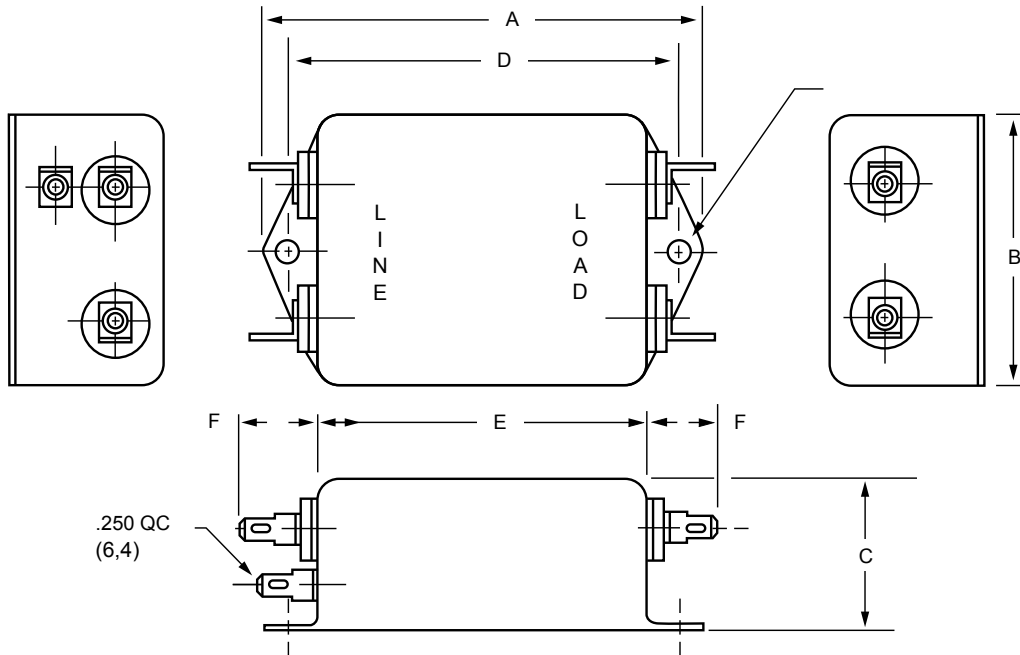

F1760/F1770/1780 (20Amp Only) Dimensions

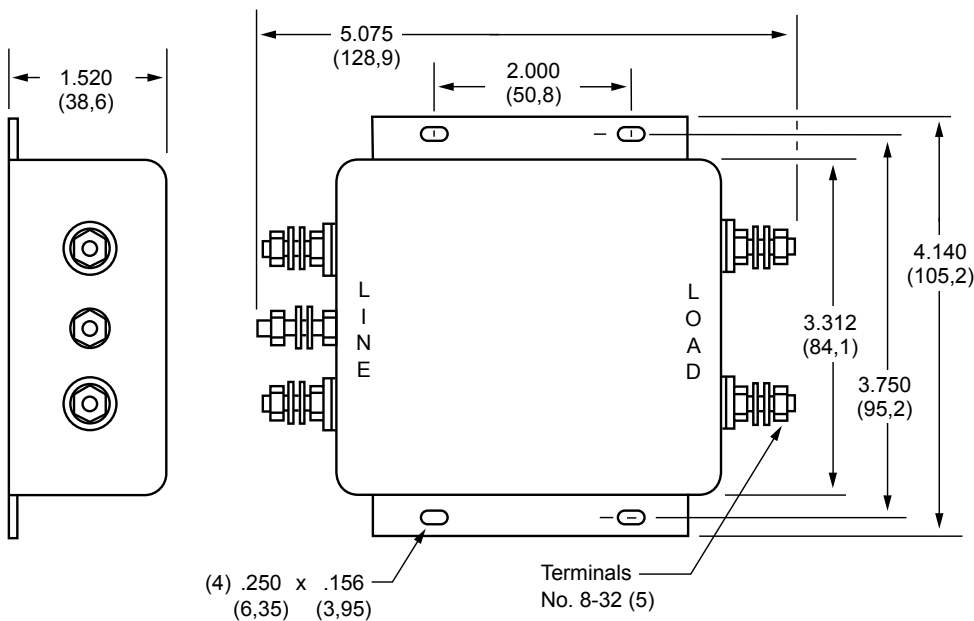

Dimensions are in inches and millimeters unless otherwise specified. Values in parentheses are metric equivalents.



F2800 RFI Filters

High Performance

SINGLE PHASE FILTERS

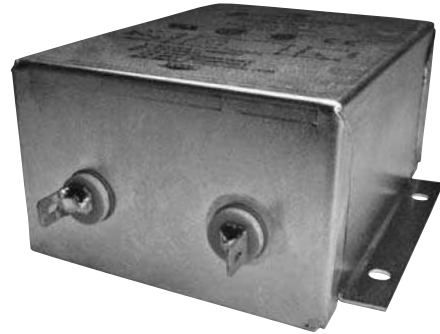

Features:

- Designed for VDE "A" and FCC "B" Switching Power Supply Applications
- Low-Leakage Current
- Compact Case Sizes in Current Ratings up to 15A
- Effective Reduction of Common Mode and Differential Mode Noise from 100KHz to 30MHz

F2800 Simplified Schematic 3 & 6Amp

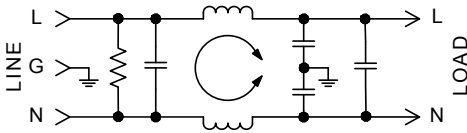

F2800 Simplified Schematic 10 & 15Amp

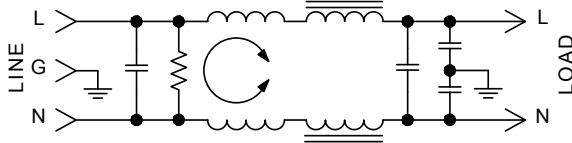

Specifications:

Rated Voltage: 250VAC Maximum - 50/60 Hz

Rated Current:	115VAC	250VAC
	3A	1.5A
	6A	4A
	10A	6A
	15A	12A

Current Overload: 6X for 8 seconds

Hi-Pot Test (1 min):

Line to Ground	1500VAC
Line to Line	1768VDC

Insulation Resistance: $9 \times 10^9 \Omega$ at 100VDC

Ambient Temperature: 40°C Max. at rated current

Humidity Range: 0% to 95% R.H.

Termination:

A: QC – Quick Connect
B: Wire

Maximum Leakage Current:

Each Line to Ground	F2800
115VAC, 60Hz:	0.25mA
250VAC, 50Hz:	0.40mA

Agency Approvals:



Nominal Current Rating	Part Number	Termination Line/Load	MINIMUM INSERTION LOSS - dB (50 ohm Circuit)										
			MODE	Frequency - MHz									
				.01	.05	.15	.50	1.0	5.0	10	30		
3A	F2800AA03	QC/QC	Common	10	30	35	35	35	40	45	50		
	F2800BB03	Wire/Wire	Differential	5	25	50	60	65	50	45	45		
6A	F2800AA06	QC/QC	Common	5	20	30	35	40	40	40	50		
	F2800BB06	Wire/Wire	Differential	5	10	40	60	60	50	50	45		
10A	F2800AA10	QC/QC	Common	5	15	25	30	35	40	45	50		
	F2800BB10	Wire/Wire	Differential	7	20	50	60	60	60	60	55		
15A	F2800AA15	QC/QC	Common	8	21	29	33	36	38	45	50		
	F2800BB15	Wire/Wire	Differential	10	30	70	70	70	70	70	60		



F2800AA (3, 6 and 10Amp) Dimensions

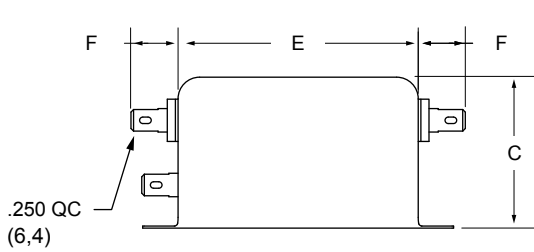
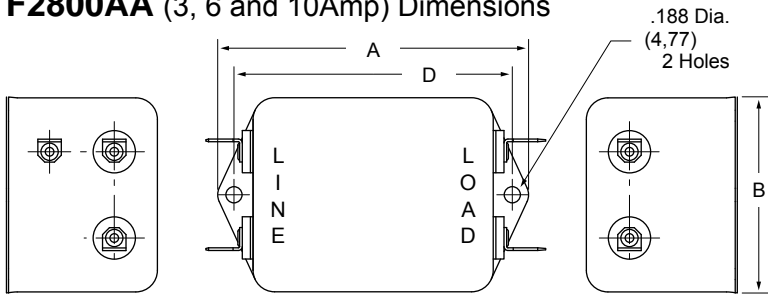

Amps	A	B	C	D	E	F
3A	3.310 (84,1)	2.000 (50,8)	1.500 (38,2)	2.940 (74,7)	2.500 (63,5)	.550 (14,0)
6A	3.310 (84,1)	2.000 (50,8)	1.500 (38,2)	2.940 (74,7)	2.500 (63,5)	.550 (14,0)
10A	4.44 (113)	2.250 (57,1)	1.750 (44,4)	4.063 (103,2)	3.630 (92,2)	.650 (16,5)

F2800BB (3, 6 and 10Amp) Dimensions

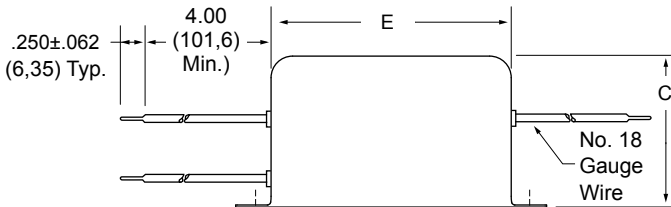
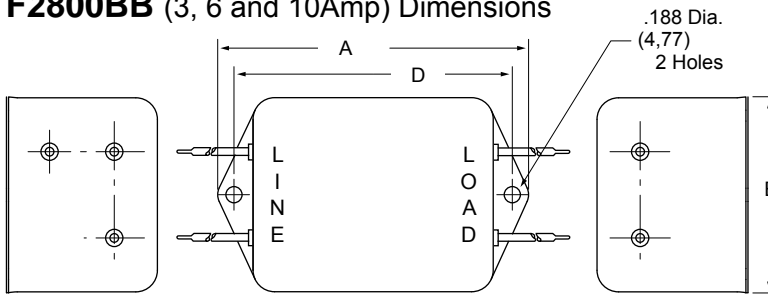

Amps	A	B	C	D	E
3A	3.310 (84,1)	2.000 (50,8)	1.500 (38,1)	2.940 (74,7)	2.500 (63,5)
6A	3.310 (84,1)	2.000 (50,8)	1.500 (38,1)	2.940 (74,7)	2.500 (63,5)
10A	4.690 (119)	2.250 (57,1)	1.750 (44,4)	4.063 (103,2)	3.630 (92,2)

**F2800AA
F2800BB
(15Amp)
Dimensions**

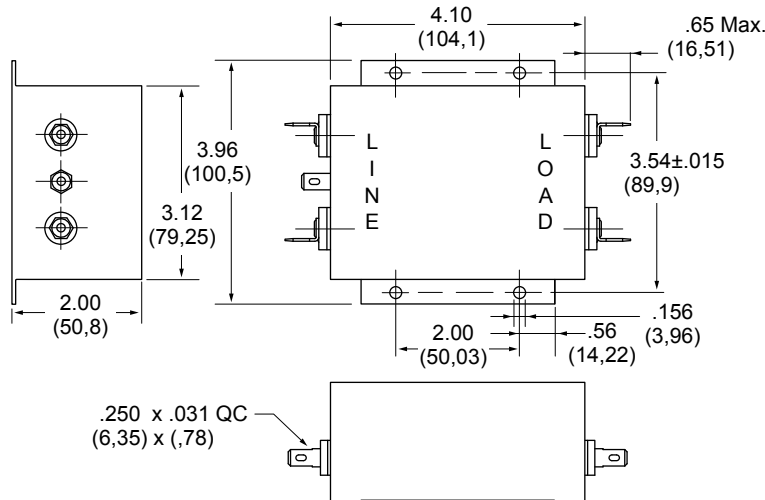

Dimensions are in inches and millimeters unless otherwise specified. Values in parentheses are metric equivalents.



F5100 RFI Filters

Wide Band

SINGLE PHASE FILTERS

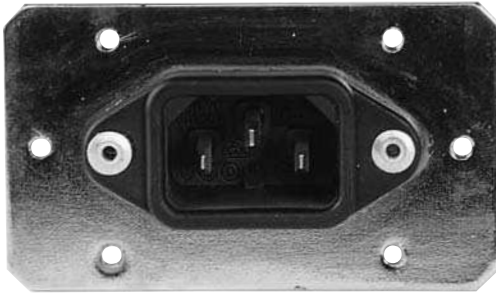

Ideal for Linear Power Supplies in Digital Equipment

Features:

- General Purpose Filter with Extended High-Frequency Insertion Loss Characteristics
- Effective Suppression of Incoming Common Mode and Differential Mode Noise
- Low-Profile Package with Integral IEC Connector
- Available in 3, 6 and 10Amp Ratings

Nominal Current Rating	Part Number	Termination Line/Load
3A	F5100CG03	IEC/ Solder Tab
6A	F5100CG06	IEC/ Solder Tab
10A	F5100CG10	IEC/ Solder Tab

Specifications:

Rated Voltage: 250VAC Maximum - 50/60 Hz

Rated Current:

115VAC	250VAC
3A	1.5A
6A	4A
10A	6A

Current Overload: 6X for 8 seconds

Hi-Pot Test (1 min):

Line to Ground	1400VDC
Line to Line	1450VDC

Insulation Resistance: $9 \times 10^9 \Omega$ at 100VDC

Ambient Temperature: 40°C Max. at rated current

Humidity Range: 0% to 95% R.H.

Termination:

C: IEC Receptacle
G: Wire Wrap/Solder

Maximum Leakage Current:

Each Line to Ground	F5100
115VAC, 60Hz:	0.25mA
250VAC, 60Hz:	0.50mA

Agency Approvals:



F5100 Simplified Schematic

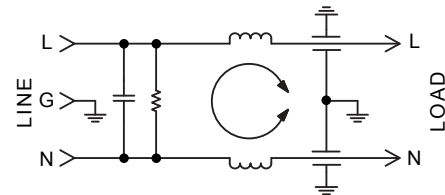

**F5100 SERIES
TYPICAL COMMON MODE
INSERTION LOSS — dB
(50 OHM CIRCUIT)**

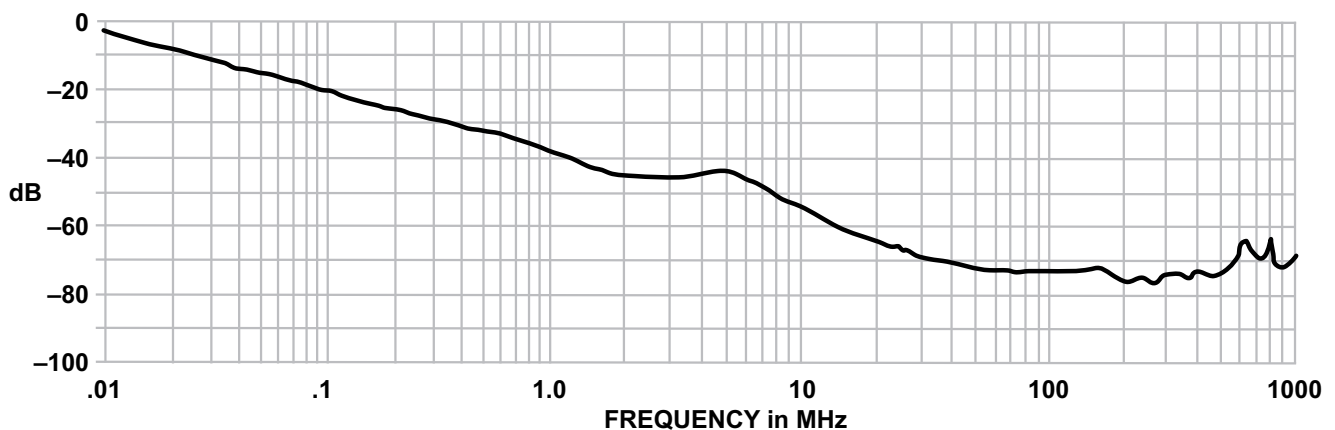

F5100CG (3, 6 and 10Amp) Dimensions

Refer to Page 41
for Standard
Mounting Cutouts

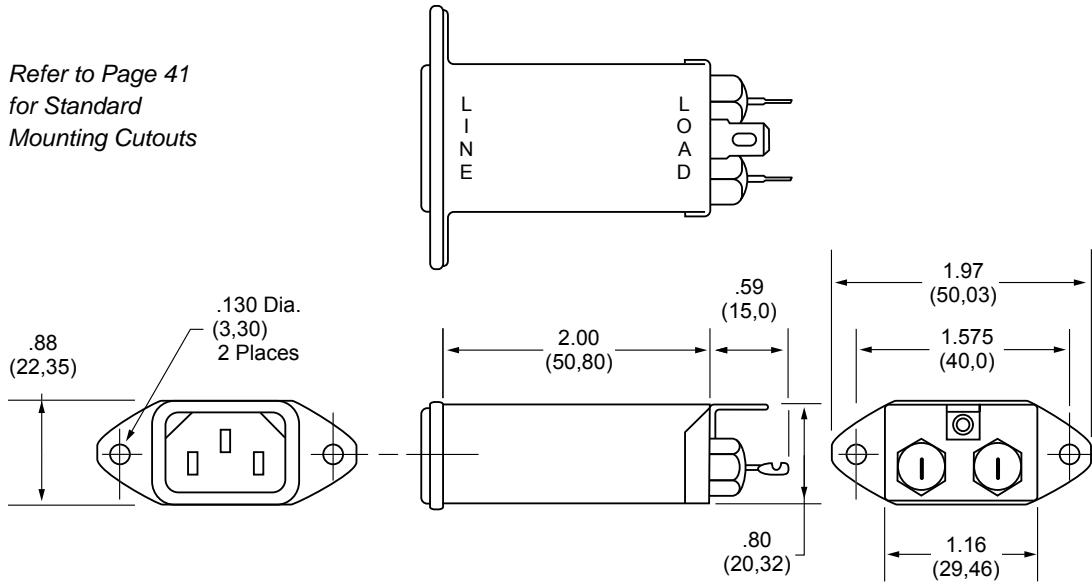
**F5101CG** (3, 6 and 10Amp) Dimensions with attached mounting plate

Refer to Page 41
for Standard
Mounting Cutouts

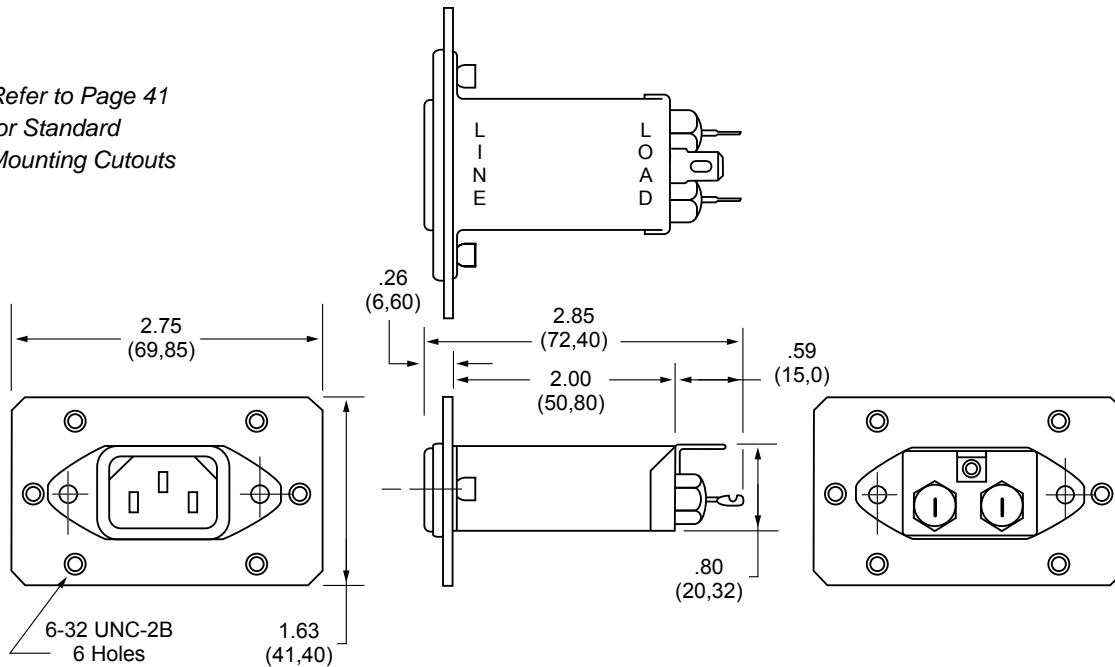

F5200 RFI Filters

Wide Band

SINGLE PHASE FILTERS

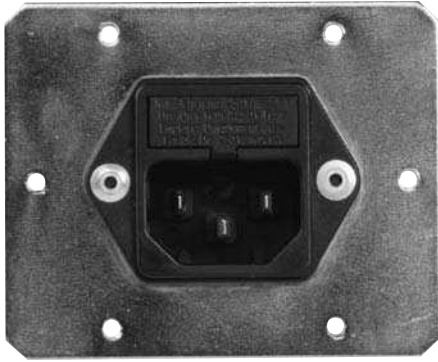

Ideal for Linear Power Supplies in Digital Equipment

Features:

- General Purpose Filter with Extended High-Frequency Insertion Loss Characteristics
- Effective Suppression of Incoming Common Mode and Differential Mode Noise
- Low-Profile Package with Integral IEC Connector
- Available in 3 and 6Amp Ratings

Nominal Current Rating	Part Number	Termination Line/Load
3A	F5200FG03	Fused IEC/ Solder Tab
6A	F5200FG06	Fused IEC/ Solder Tab

Specifications:

Rated Voltage: 250VAC Maximum - 50/60 Hz

Rated Current: 115VAC 250VAC
 3A 1.5A
 6A 4A

Current Overload: 6X for 8 seconds

Hi-Pot Test (1 min):

Line to Ground 1400VDC
Line to Line 1450VDC

Insulation Resistance: $9 \times 10^9 \Omega$ at 100VDC

Ambient Temperature: 40°C Max. at rated current

Humidity Range: 0% to 95% R.H.

Termination:

F: Fused IEC Receptacle
G: Wire Wrap/Solder

Maximum Leakage Current:

Each Line to Ground **F5200**
115VAC, 60Hz: 0.25mA
250VAC, 60Hz: 0.50mA

Agency Approvals:



F5200 Simplified Schematic

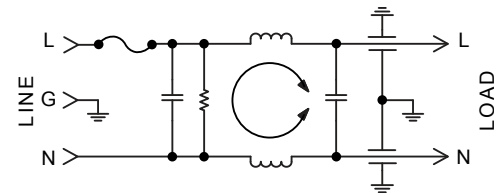

**F5200 SERIES
TYPICAL COMMON MODE
INSERTION LOSS — dB
(50 OHM CIRCUIT)**

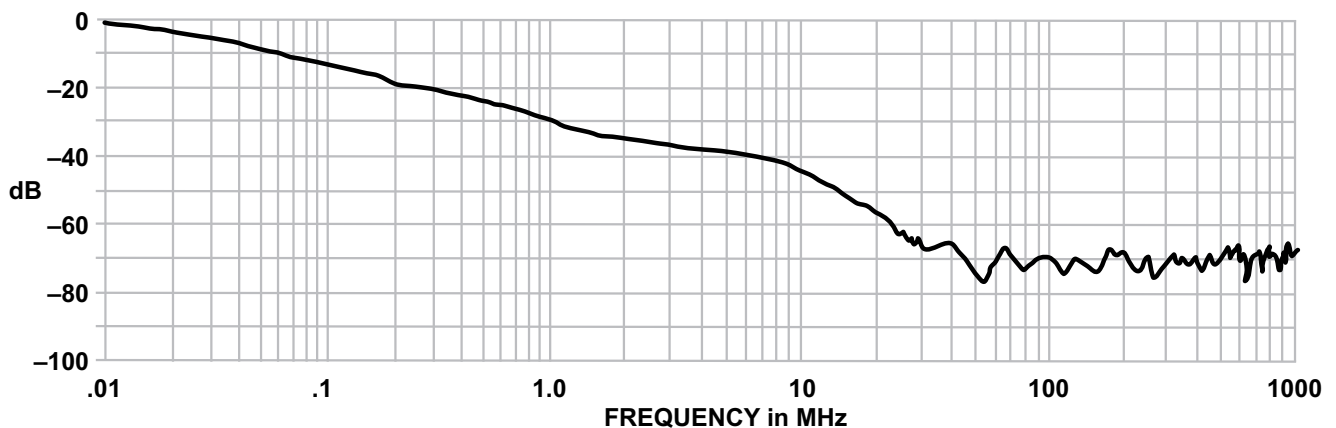

F5200FG (3 and 6Amp) Dimensions

Refer to Page 41
for Standard
Mounting Cutouts

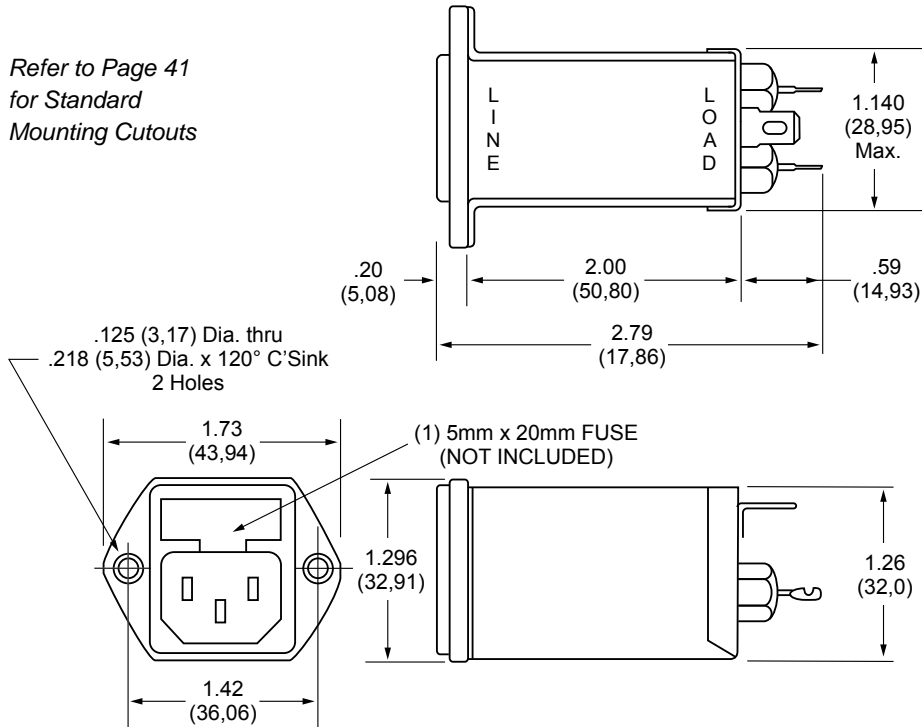
**F5201FG (3 and 6Amp) Dimensions with attached mounting plate**

Refer to Page 41
for Standard
Mounting Cutouts

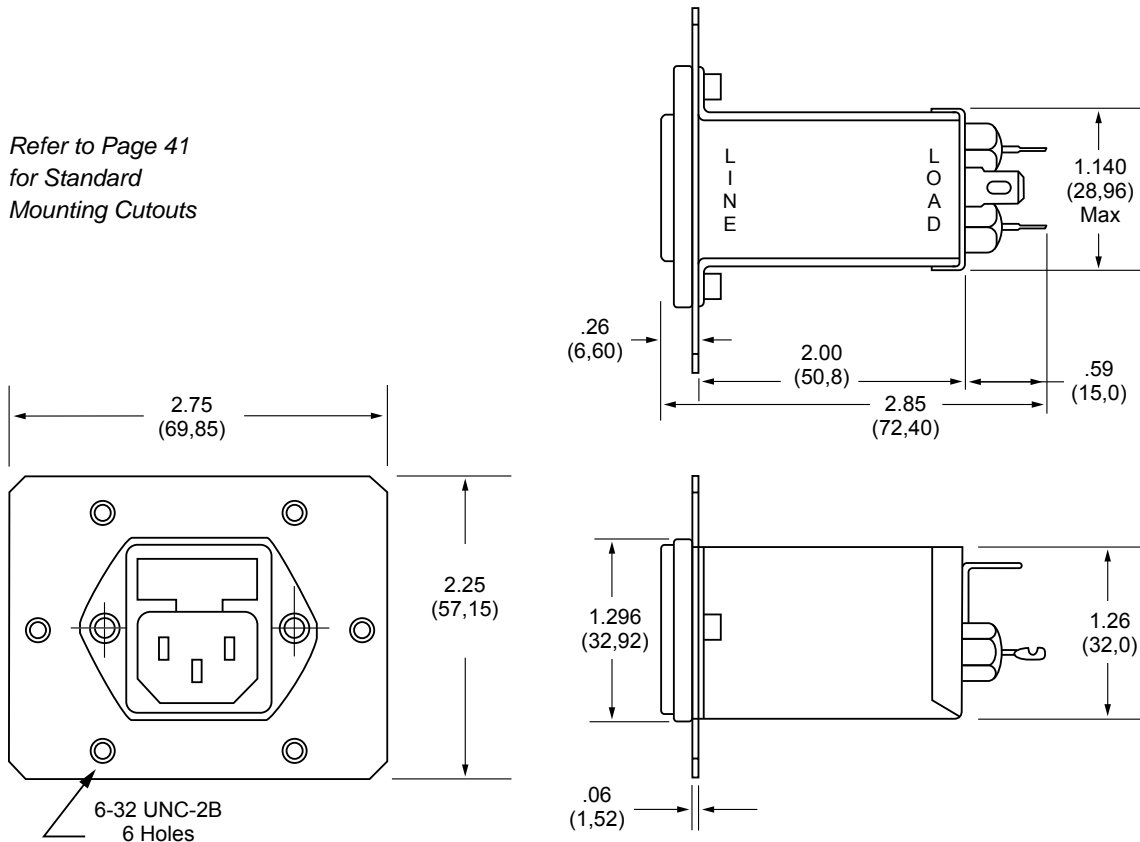

Dimensions are in inches and millimeters
unless otherwise specified.
Values in parentheses are metric equivalents.



Curtis Industries
A Division of Powers Holdings, Inc.

F5500 RFI Filters

Wide Band

SINGLE PHASE FILTERS



Ideal for Linear and Switching Power Supplies

Features:

- FCC and VDE Level "A" Applications
- High Inductance Single Coil Design Provides High Common Mode and Differential Mode Performance Above 150KHz
- High-Frequency Construction Techniques Maintain >50dB Insertion Loss from 10MHz to 1GHz
- Compact, Space-Saving Package Available in 3, 6 and 10-Amp Ratings

F5500 Simplified Schematic

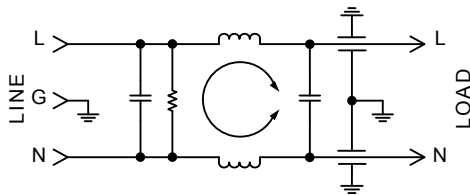

Specifications:

Rated Voltage: 250VAC Maximum - 50/60 Hz

Rated Current:

115VAC	250VAC
3A	3A
6A	4A
10A	6A

Current Overload: 6X for 8 seconds

Hi-Pot Test (1 min):

Line to Ground	1400VDC
Line to Line	1450VDC

Insulation Resistance: $9 \times 10^9 \Omega$ at 100VDC

Ambient Temperature: 40°C Max. at rated current

Humidity Range: 0% to 95% R.H.

Termination:

C: IEC Receptacle
G: Wire Wrap/Solder

Maximum Leakage Current:

Each Line to Ground	F5500
115VAC, 60Hz:	0.25mA
250VAC, 60Hz:	0.50mA

Agency Approvals:



Nominal Current Rating	Part Number	Termination Line/Load
3A	F5500CG03	IEC/ Solder Tab
6A	F5500CG06	IEC/ Solder Tab
10A	F5500CG10	IEC/ Solder Tab

**F5500 SERIES
TYPICAL COMMON MODE
INSERTION LOSS — dB
(50 OHM CIRCUIT)**

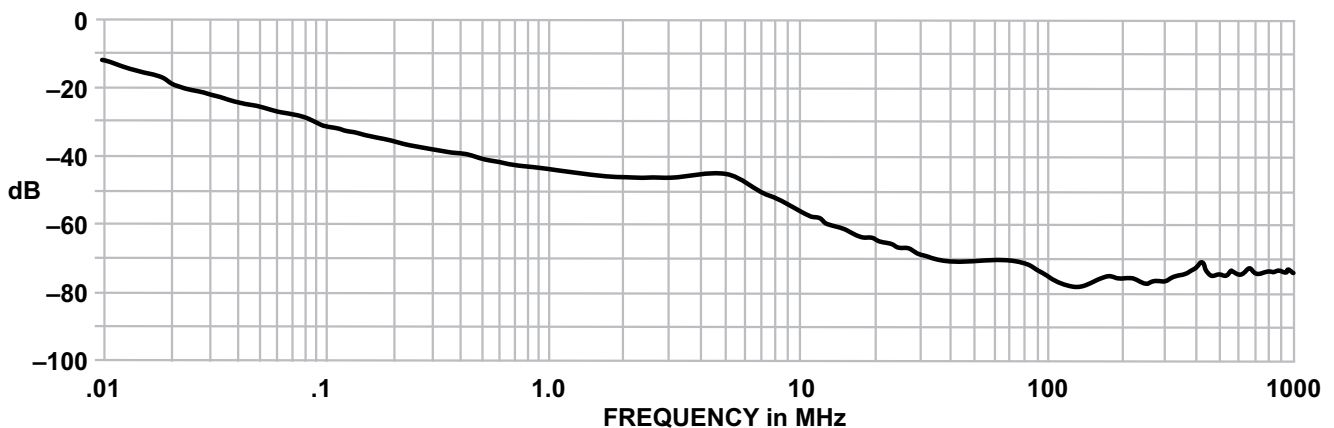

F5500CG (3, 6 and 10Amp) Dimensions

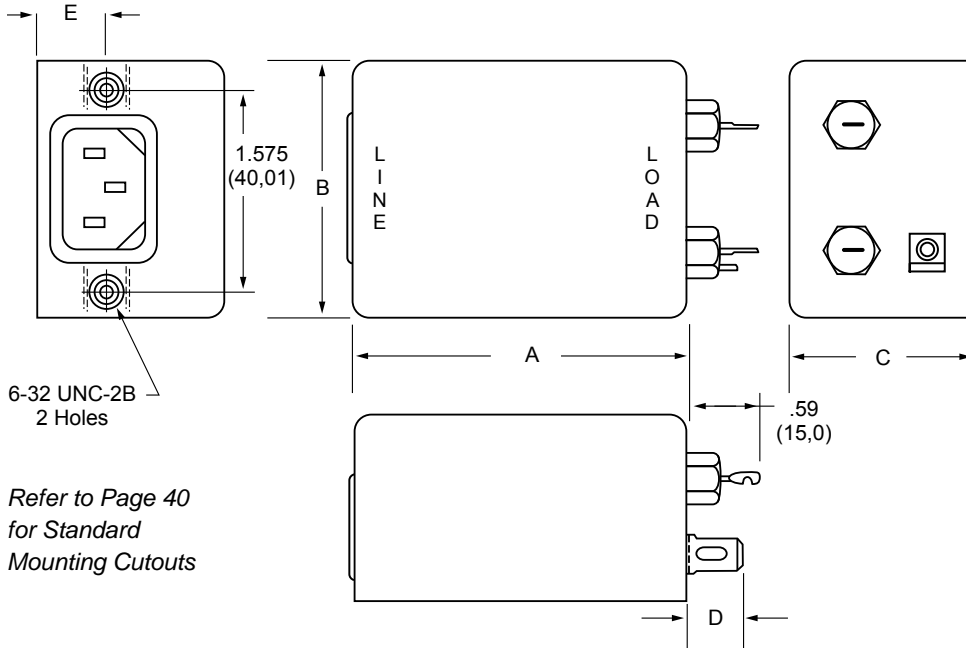

6-32 UNC-2B
2 Holes

Refer to Page 40
for Standard
Mounting Cutouts

Amps	A	B	C	D	E
3A	2.000 (50,8)	2.000 (50,8)	1.500 (38,2)	.450 (11,4)	.565 (14,3)
6A	2.88 (73,1)	2.13 (54,1)	1.500 (38,2)	.450 (11,4)	.565 (14,3)
10A	2.88 (73,1)	2.13 (54,1)	1.500 (38,2)	.450 (11,4)	.565 (14,3)

F5501CG (3, 6 and 10Amp) Dimensions
with attached mounting plate

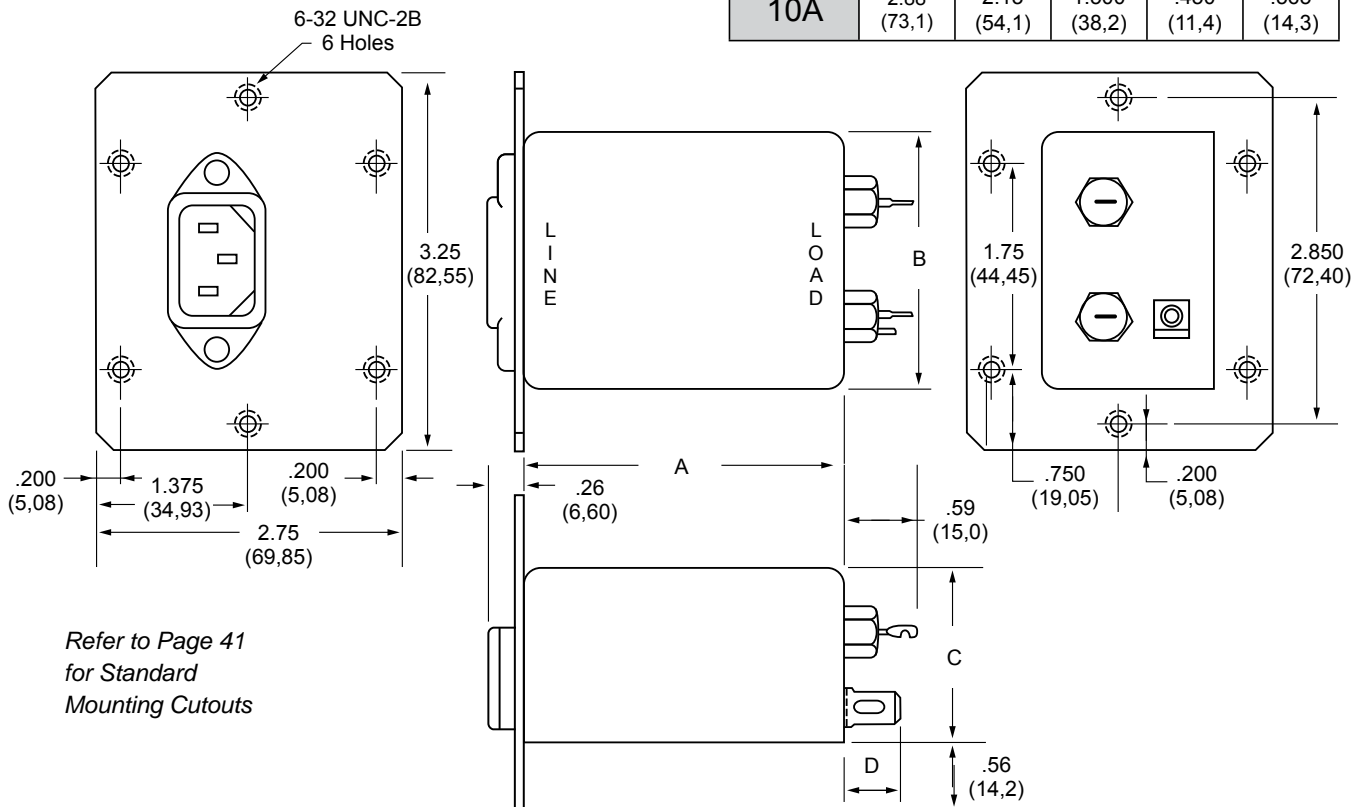

Refer to Page 41
for Standard
Mounting Cutouts

Dimensions are in inches and millimeters
unless otherwise specified.
Values in parentheses are metric equivalents.



F5600 RFI Filters

Wide Band

SINGLE PHASE FILTERS

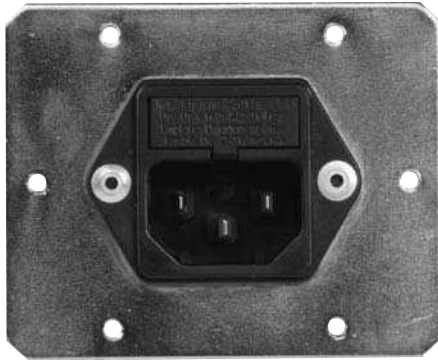

Features:

- Suited for FCC "B" and VDE "A" Switching Power Supply Applications
- High Inductance, Multi-Stage Design with High Common Mode and Differential Mode Insertion Loss for Switching Power Supply Emissions
- >70dB Insertion Loss from 200KHz to 1GHz
- Compact, Space-Efficient Package Available in 3 and 6Amp Ratings

Specifications:

Rated Voltage: 250VAC Maximum - 50/60 Hz

Rated Current:

115VAC	250VAC
3A	1.5A
6A	4A

Current Overload: 6X for 8 seconds

Hi-Pot Test (1 min):

Line to Ground	1400VDC
Line to Line	1450VDC

Insulation Resistance: $9 \times 10^9 \Omega$ at 100VDC

Ambient Temperature: 40°C Max at rated current

Humidity Range: 0% to 95% R.H.

Termination:

- C: IEC Receptacle
- F: Fused IEC Receptacle
- G: Wire Wrap/Solder

Termination: Quick Connect

Maximum Leakage Current:

Each Line to Ground	F5600
115VAC, 60Hz:	0.50mA
250VAC, 60Hz:	1.20mA

Agency Approvals:



Nominal Current Rating	Part Number	Termination Line/Load
3A	F5600CG03	IEC/Solder Tab
	F5600FG03	Fused IEC/Solder Tab
6A	F5600CG06	IEC/Solder Tab
	F5600FG06	Fused IEC/Solder Tab

F5600 Simplified Schematic

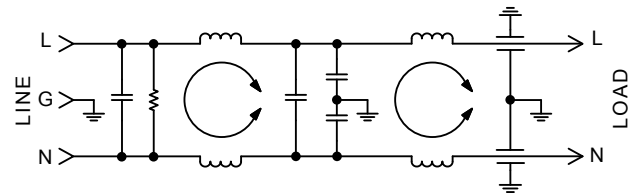

**F5600 SERIES
TYPICAL COMMON MODE
INSERTION LOSS — dB
(50 OHM CIRCUIT)**

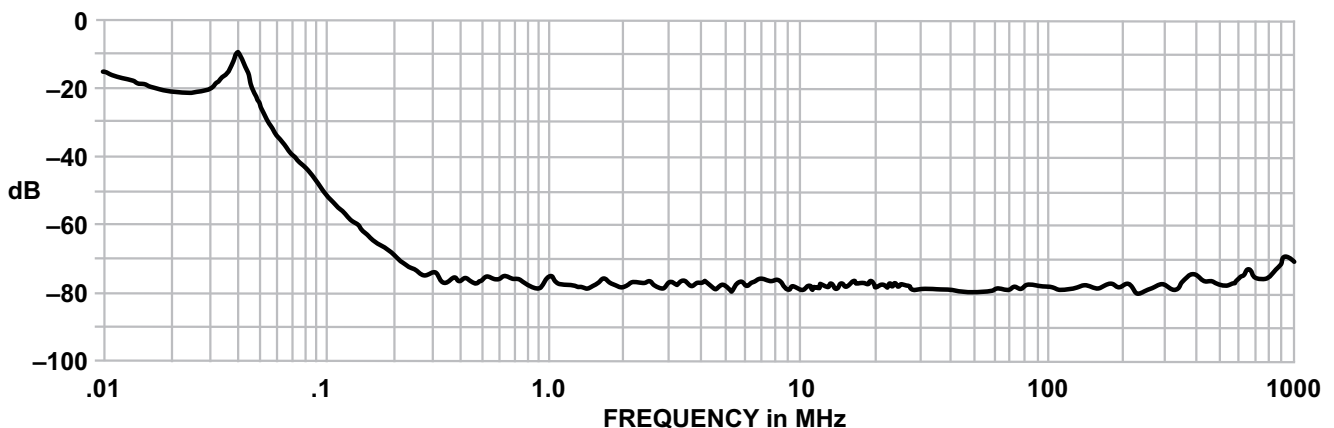

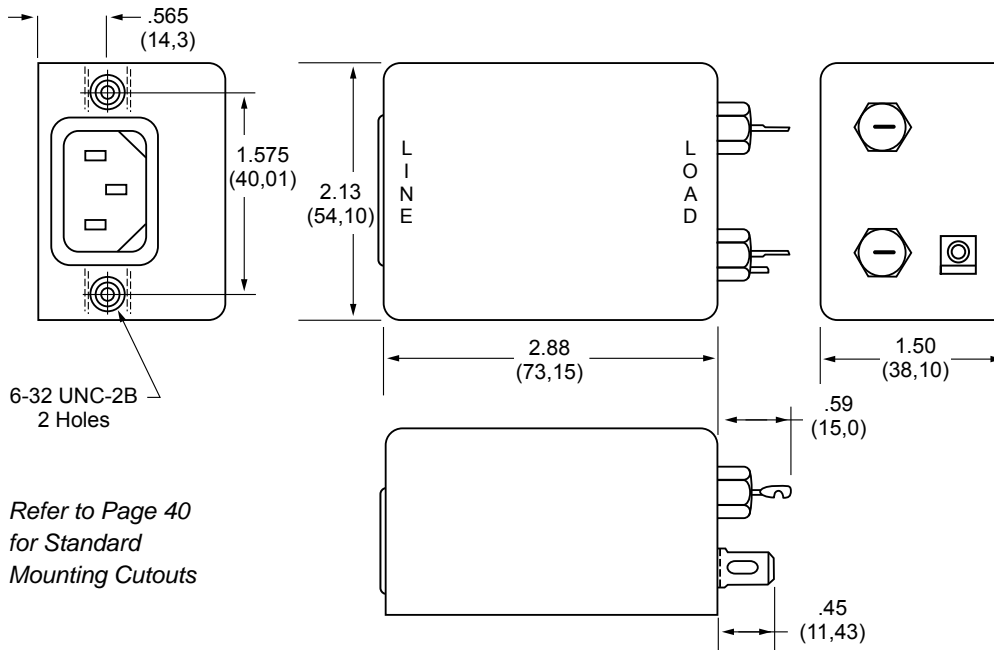
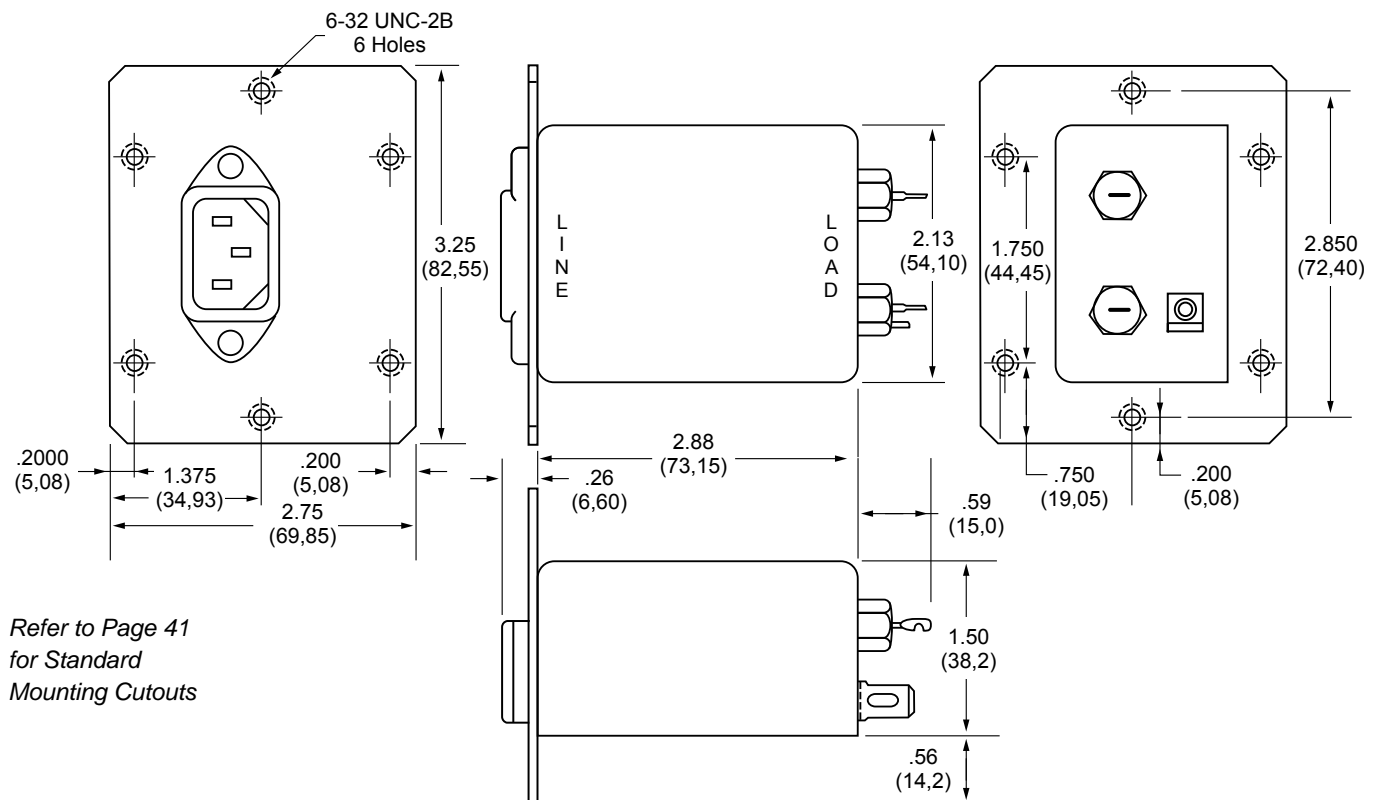
F5600CG (3 and 6Amp) Dimensions**F5601CG (3 and 6Amp) Dimensions with attached mounting plate**

F5700 RFI Filters

Wide Band

SINGLE PHASE FILTERS



Features:

- Ideal for VDE "B" and MIL-STD-461 Switching Power Supply Applications
- Very High Inductance Design with Differential Mode Choke to Provide Improved Performance Below 100KHz
- Wide-Band Insertion Loss >60dB from 10MHz to 1GHz
- Compact, Space-Efficient Package Available in 3 and 6Amp Ratings

F5700 Simplified Schematic

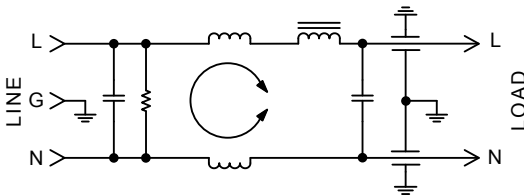

Specifications:

Rated Voltage: 250VAC Maximum - 50/60 Hz

Rated Current: 115VAC 250VAC
3A 2A
6A 4A

Current Overload: 6X for 8 seconds

Hi-Pot Test (1 min):

Line to Ground 1400VDC

Line to Line 1450VDC

Insulation Resistance: $9 \times 10^9 \Omega$ at 100VDC

Ambient Temperature: 40°C Max. at rated current

Humidity Range: 0% to 95% R.H.

Termination:

C: IEC Receptacle

G: Wire Wrap/Solder

Maximum Leakage Current:

Each Line to Ground **F5700**

115VAC, 60Hz: 0.50mA

250VAC, 60Hz: 1.20mA

Agency Approvals:



Nominal Current Rating	Part Number	Termination Line/Load
3A	F5700CG03	IEC/ Solder Tab
6A	F5700CG06	IEC/ Solder Tab

F5700 SERIES
TYPICAL COMMON MODE
INSERTION LOSS — dB
(50 OHM CIRCUIT)

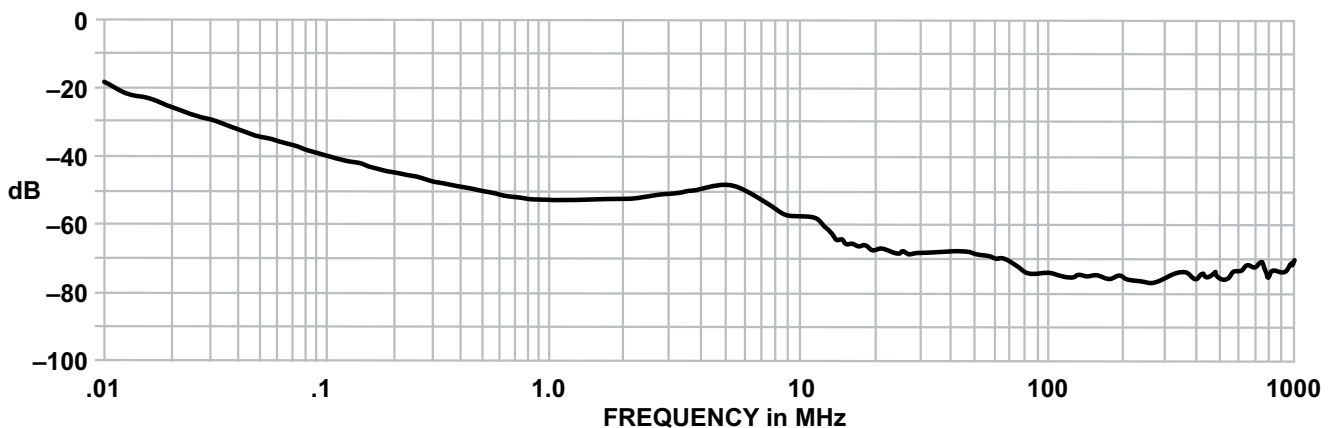

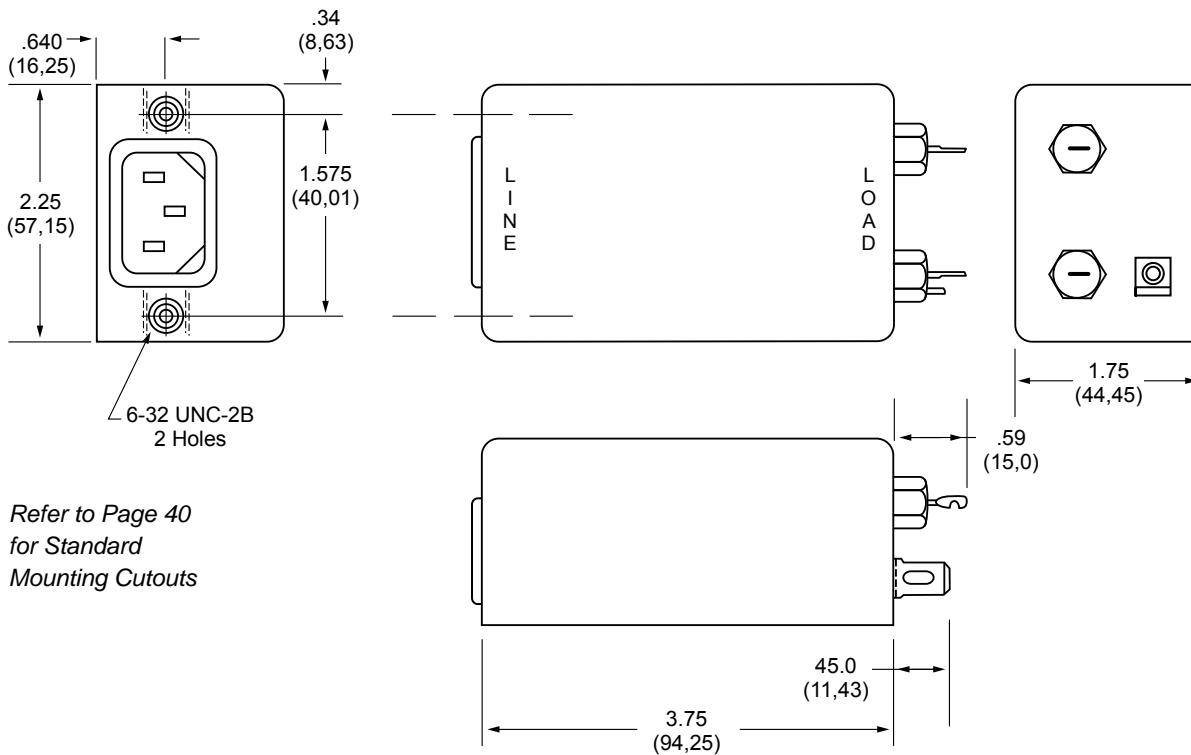
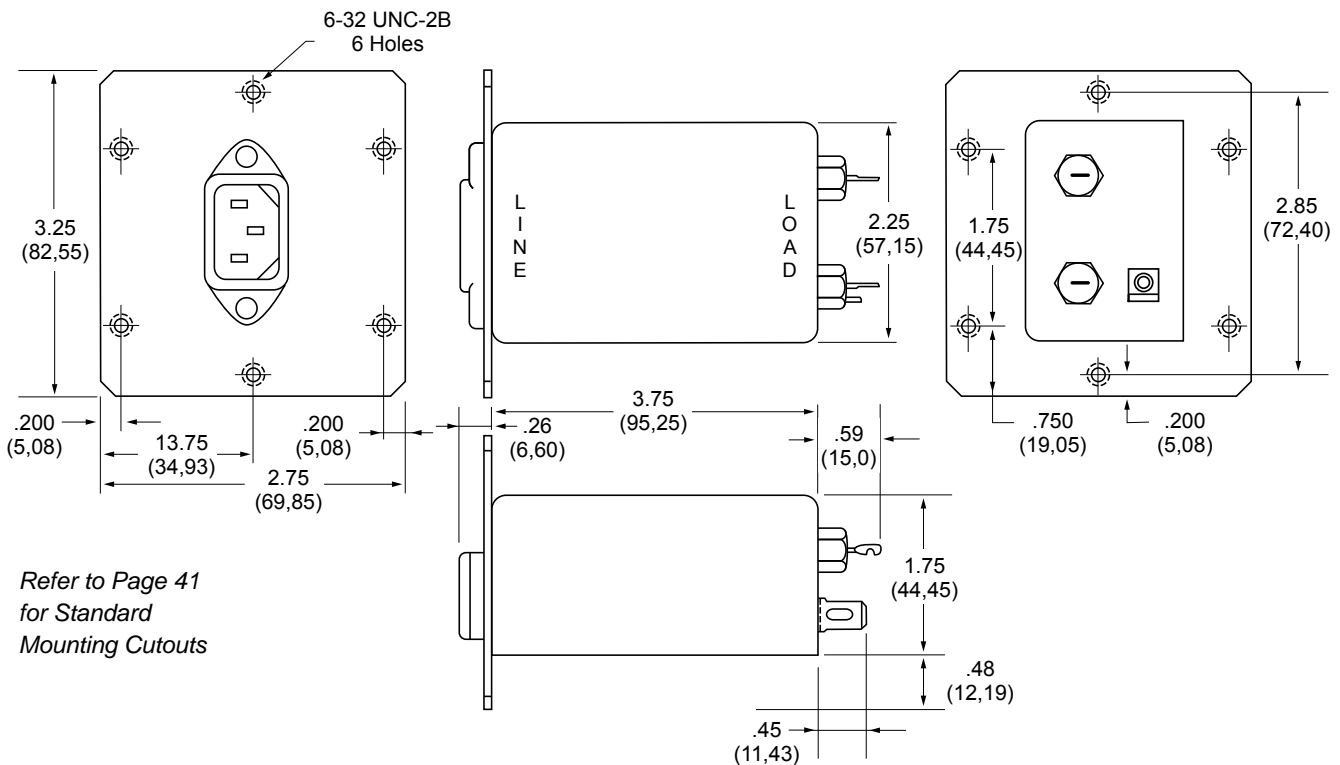
F5700CG (3 and 6Amp) Dimensions**F5701CG (3 and 6Amp) Dimensions with attached mounting plate**

F5900 RFI Filters

Wide Band

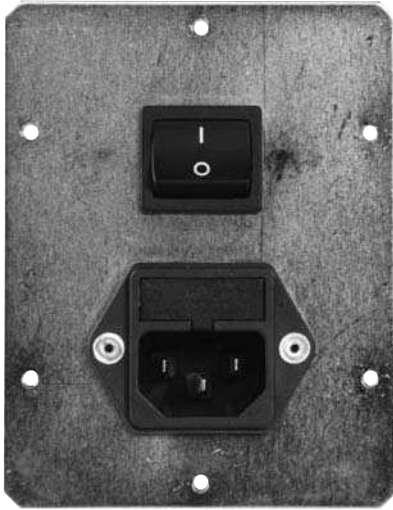

Features:

- High Performance Filter Designed for Switching Power Supply Emissions
- >70dB Insertion Loss from 200KHz to 1GHz
- Integral Power Switch and 5 x 20mm Fuse Holder
- Available in 3 and 6Amp Versions with Optional Mounting Faceplates

F5900 Simplified Schematic without Switch

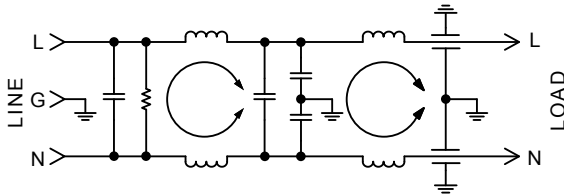

Specifications:

Rated Voltage: 250VAC Maximum - 50/60 Hz

Rated Current:

115VAC	250VAC
3A	1.5A
6A	4A

Current Overload: 6X for 8 seconds

Hi-Pot Test (1 min):

Line to Ground	1500VDC
Line to Line	1450VDC

Insulation Resistance: $9 \times 10^9 \Omega$ at 100VDC

Ambient Temperature: 40°C Max. at rated current

Humidity Range: 0% to 95% R.H.

Termination:

- C: IEC Receptacle
- F: Fused IEC
- G: Wire Wrap/Solder
- J: Switched IEC

Maximum Leakage Current:

Each Line to Ground	F5900
115VAC, 60Hz:	0.50mA
250VAC, 60Hz:	1.20mA

Agency Approvals:



F5900 Simplified Schematic with Switch

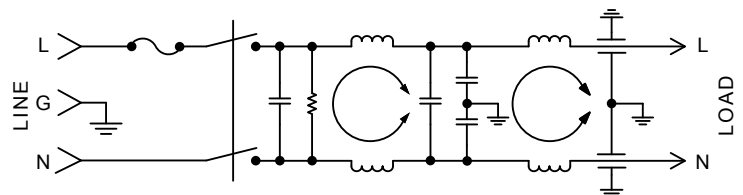

**F5900 SERIES
TYPICAL COMMON MODE
INSERTION LOSS — dB
(50 OHM CIRCUIT)**

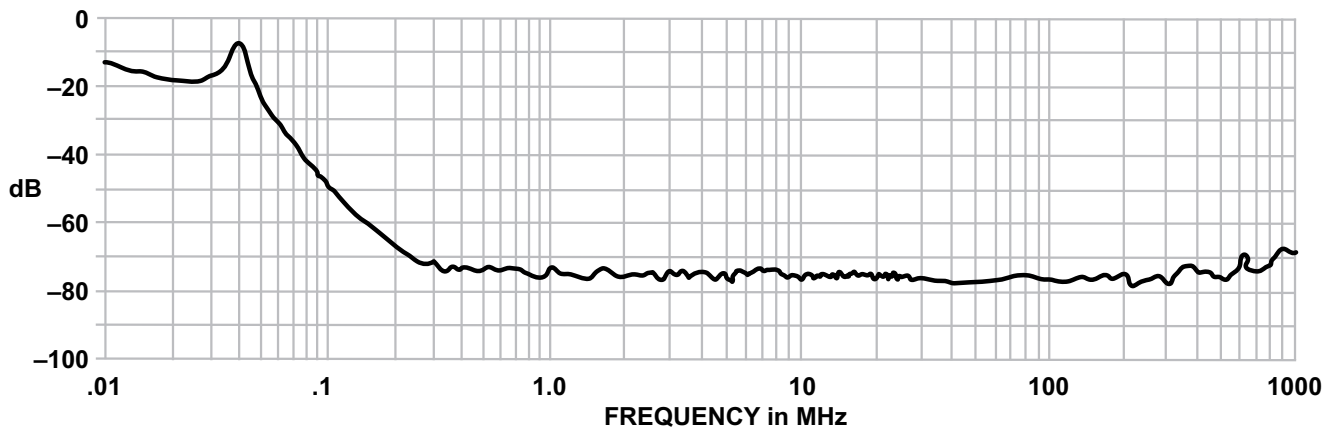

F5900CG (3 and 6Amp) Dimensions

Refer to Page 42
for Standard
Mounting Cutouts

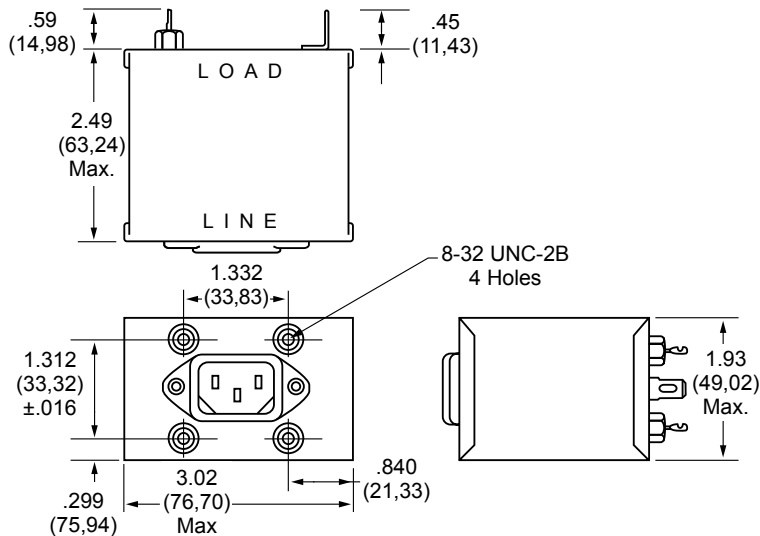

F5900FG (3 and 6Amp) Dimensions

Refer to Page 42 for Standard Mounting Cutouts

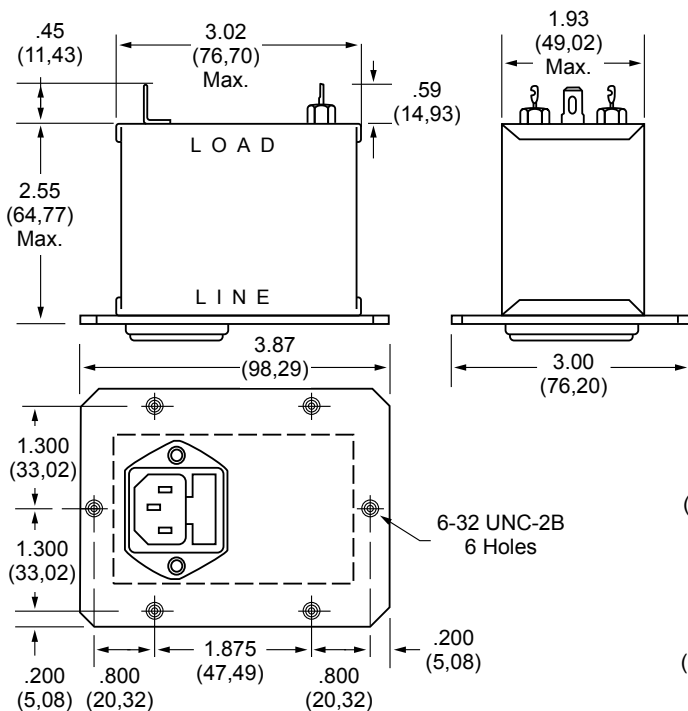

Nominal Current Rating	Part Number	Termination Line/Load
3A	F5900CG03	IEC/Solder Tab
	F5900FG03	Fused IEC/Solder Tab
	F5900JG03	Switched IEC/Solder Tab
6A	F5900CG06	IEC/Solder Tab
	F5900FG06	Fused IEC/Solder Tab
	F5900JG06	Switched IEC/Solder Tab

F5900JG (3 and 6Amp) Dimensions

Refer to Page 42
for Standard
Mounting Cutouts

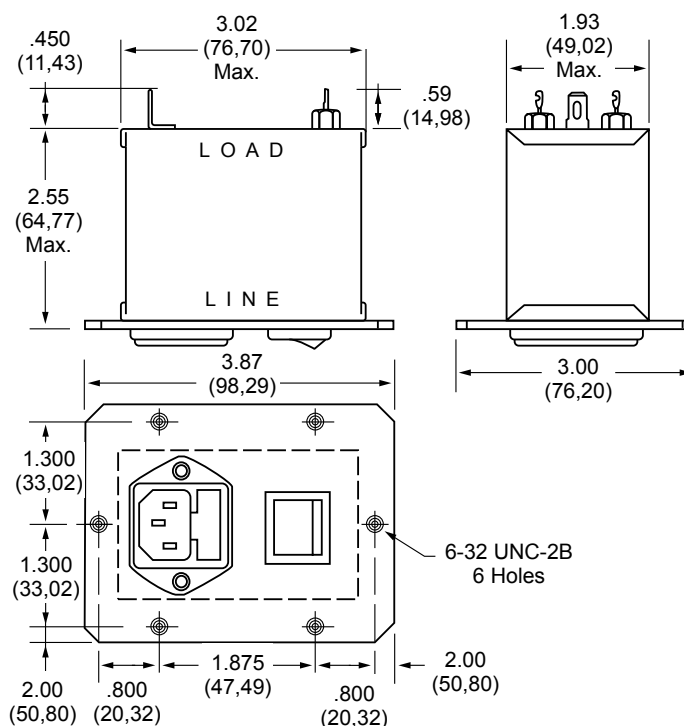

Standard Mounting Cutouts

F1200CA, F1300CA, F1400CA, F1500CA, F1600CA, F1700CA

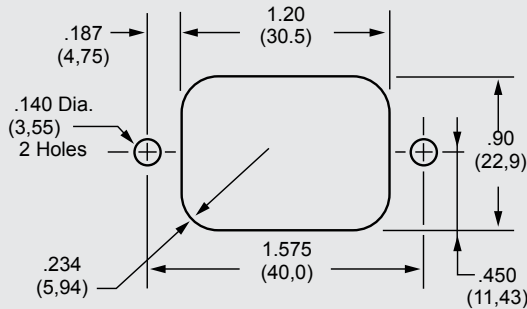

F1500FA, F1600FA,

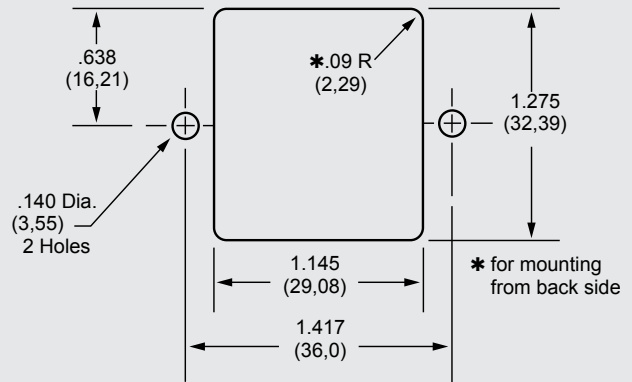

How to Order

The Curtis part numbering system is made up of four elements. Each element denotes a specific requirement (mechanical or electrical) which, when properly sequenced, fully identifies the required catalog filter. As shown, the first five alpha/numeric characters denote the series type; the sixth character (alpha) denotes the type of line termination; the seventh character (alpha) denotes the type of load termination; the last two characters (numeric) denote the current rating.

Compose your part number as follows: Select the series required, add two alpha character for the line and load termination, followed by two numeric characters for the required current rating. For example, F1100AB06 completely identifies an F1100 series filter with quick connects on line side and wire leads on load side, with a 6-amp rating.

SINGLE PHASE FILTERS

F1300CP, F1600CP

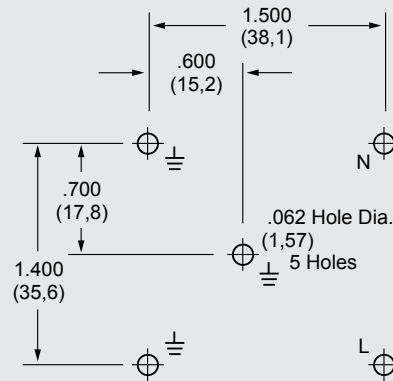

F5500/5600/5700 SERIES

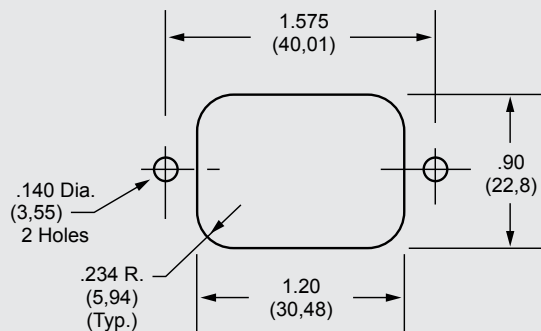

F1100	X	X	X
SERIES	LINE TERMINATION	LOAD TERMINATION	CURRENT RATING
PE = Power Entry PM = Medical Power Entry	A = Quick Connects B = Wire Leads C = IEC Connector D = Screw Terminals (20 & 30 amp only) F = Fused IEC P = Printed Circuit Pins W = Dual Fused IEC J = Switched IEC	A = Quick Connects B = Wire Leads (20 & 30 amp only) D = Screw Terminals P = Printed Circuit Pins S = Solder Tab	01 = 1 Amp 03 = 3 Amps 06 = 6 Amps 10 = 10 Amps 15 = 15 Amps 20 = 20 Amps 30 = 30 Amps



F5100 SERIES

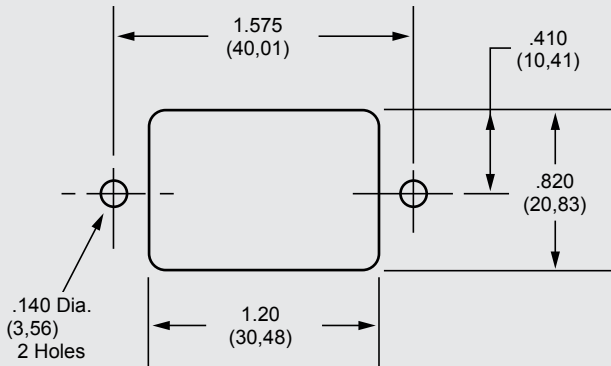

F5200 SERIES

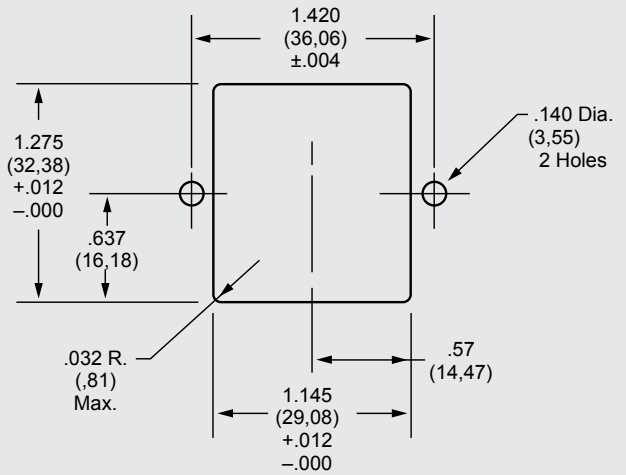

F5101 SERIES

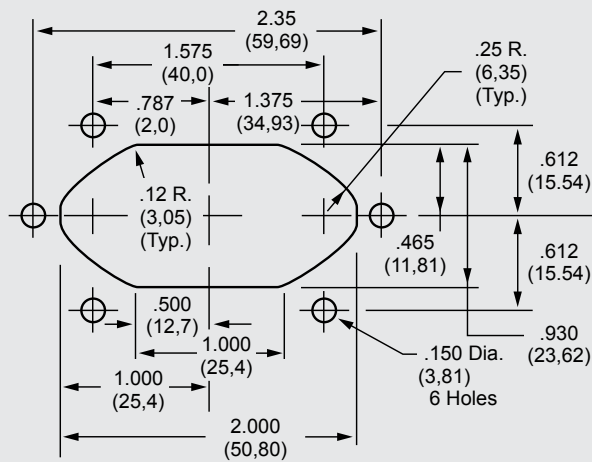

F5201 SERIES

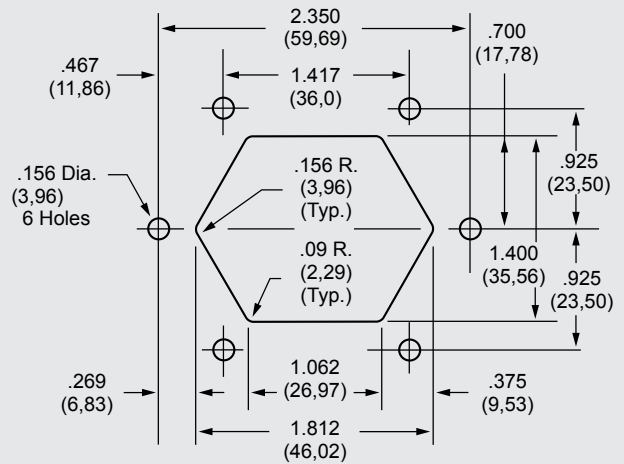

F5501/5601/5701 SERIES

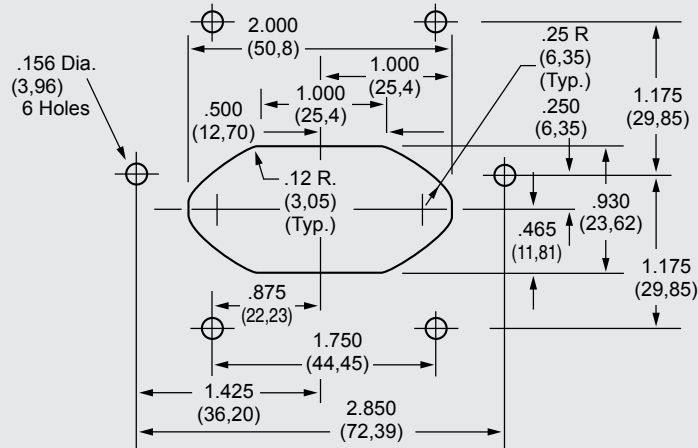

NOTE: Tolerance for all dimensions unless otherwise specified: .XXX three place ± .004, .XX two place ± 0.10

Dimensions are in inches and millimeters unless otherwise specified. Values in parentheses are metric equivalents.



Curtis Industries
A Division of Powers Holdings, Inc.

1-800-657-0853

Standard Mounting Cutouts

SINGLE PHASE FILTERS

F5900FG

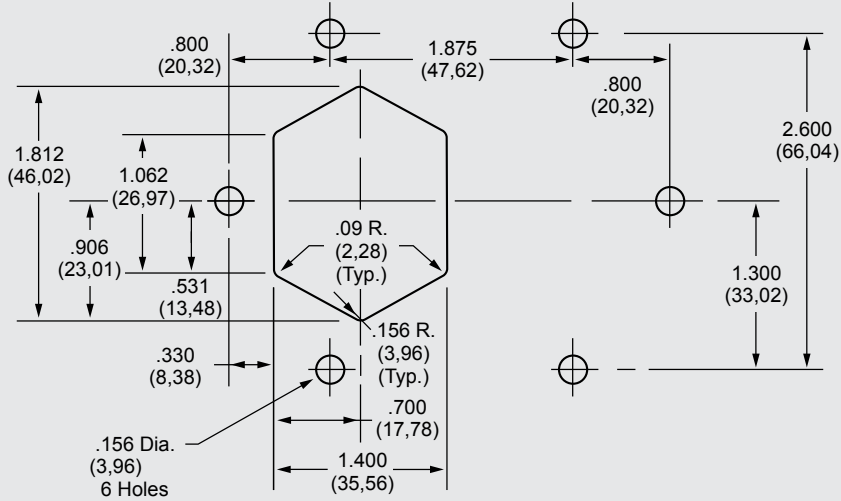

F5900CG

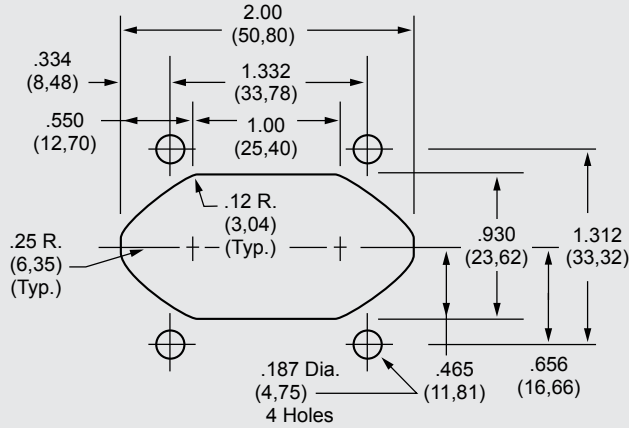

F5900JG

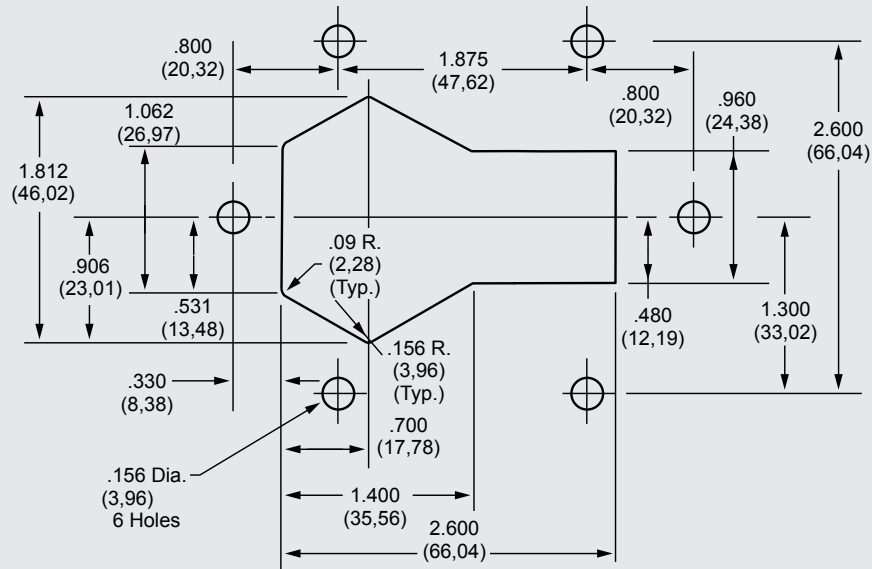

NOTE: Tolerance for all dimensions unless otherwise specified: .XXX three place $\pm .004$, .XX two place ± 0.10



POWER ENTRY MODULES]

General Purpose Combination



F2199/F2200 RFI Filters



Features:

- General Purpose Filters — Designed for Common Mode Emissions or Susceptibility Applications
- Integral IEC Connector in Space-Efficient Package
- Ideal for Linear Power Supplies in Digital Equipment

F2199/F2200 Simplified Schematic

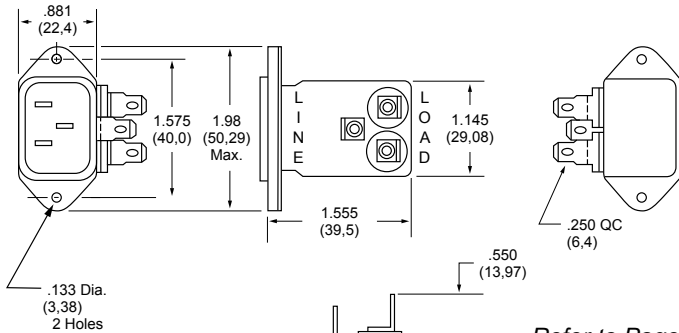
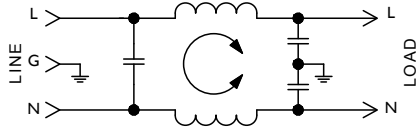

F2200CA (1, 3 and 6Amp) Dimensions

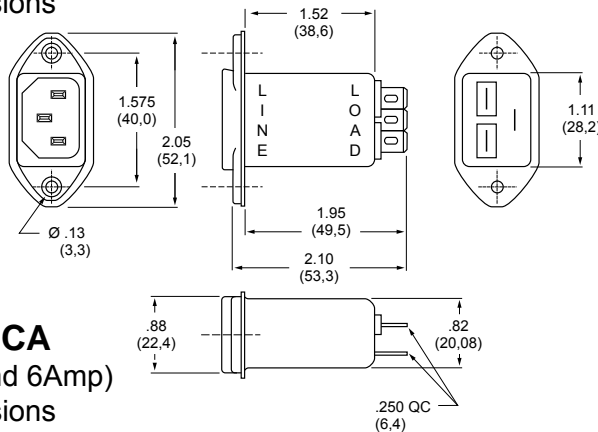

F2199CA (1, 3 and 6Amp) Dimensions

Specifications:

Rated Voltage: 250VAC Maximum - 50/60 Hz

Rated Current:	115VAC	250VAC
	1A	1A
	3A	3A
	6A	6A
	10A	8A

Current Overload: 6X for 8 seconds

Hi-Pot Test (1 min):

Line to Ground	1500VAC
Line to Line	1768VDC

Insulation Resistance: $9 \times 10^9 \Omega$ at 100VDC

Ambient Temperature: 40°C Max. at rated current

Humidity Range: 0% to 95% R.H.

Termination:

- A: QC – Quick Connect
- C: IEC Receptacle

Maximum Leakage Current:

Each Line to Ground	F2100/F2200
115VAC, 60Hz:	0.25mA
250VAC, 50Hz:	0.40mA

Agency Approvals:



Refer to Page 58
for Standard
Mounting Cutouts

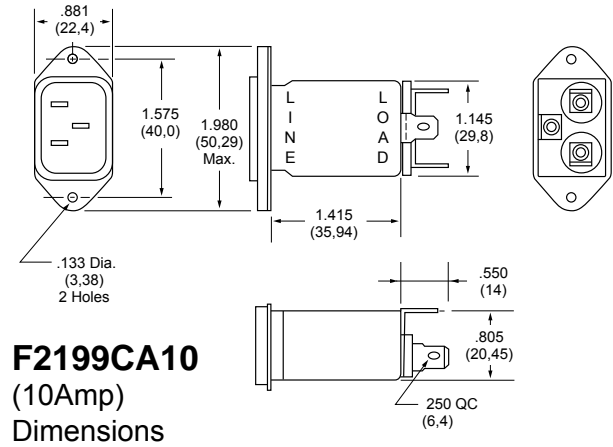

F2199CA10 (10Amp) Dimensions

Nominal Current Rating	Part Number	Termination Line/Load	MINIMUM INSERTION LOSS - dB (50 ohm Circuit)						
			MODE	Frequency - MHz					
				.15	.50	1.0	5.0	10	30
1A	F2199CA01 F2200CA01	IEC/QC IEC/QC	Common	22	35	40	46	50	50
			Differential	—	2	3	35	40	40
3A	F2199CA03 F2200CA03	IEC/QC IEC/QC	Common	15	25	30	45	50	50
			Differential	—	2	3	35	40	40
6A	F2199CA06 F2200CA06	IEC/QC IEC/QC	Common	10	20	29	43	45	50
			Differential	—	2	7	28	46	57
10A	F2199CA10	IEC/QC	Common	9	17	23	39	45	45
			Differential	—	2	7	12	37	60

NOTE: Other combinations of terminals may be specified on special order.



F2300 RFI Filters



Features:

- Effective Protection from Pulsed, Intermittent or Continuous RFI for FCC "A" Applications
- High-Performance Low-Leakage Filter in Low Profile Package with Integral IEC Connector
- Increased Inductance and Line-to-Line Capacitance Provide Enhanced Common Mode and Differential Mode Attenuation

F2300CA Simplified Schematic

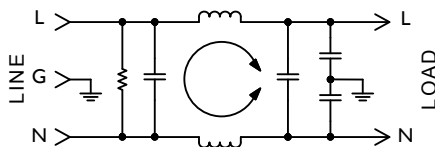

F2300CA (6Amp) Dimensions

Refer to Page 58
for Standard
Mounting Cutouts

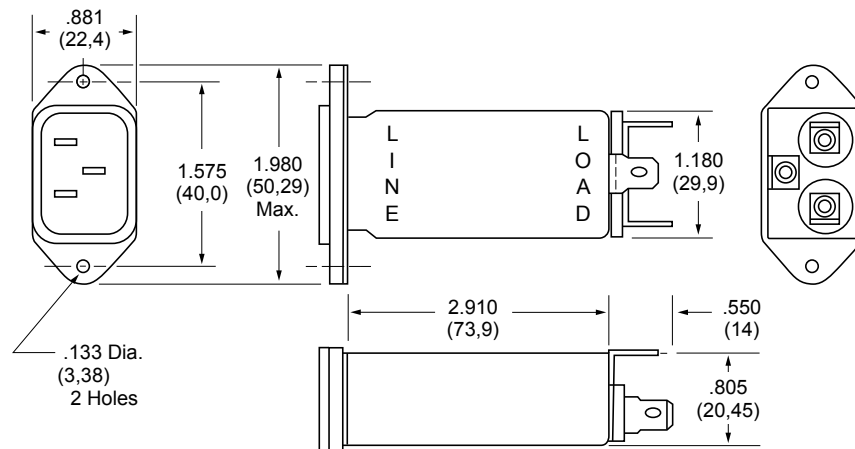

Specifications:

Rated Voltage: 250VAC Maximum - 50/60 Hz

Rated Current: 115VAC 250VAC
6A 6A

Current Overload: 6X for 8 seconds

Hi-Pot Test (1 min):

Line to Ground 1500VAC
Line to Line 1768VDC

Insulation Resistance: $9 \times 10^9 \Omega$ at 100VDC

Ambient Temperature: 40°C Max at rated current

Humidity Range: 0% to 95% R.H.

Termination:

A: QC – Quick Connect
C: IEC Receptacle

Maximum Leakage Current:

Each Line to Ground **F2300**
115VAC, 60Hz: 0.25mA
250VAC, 50Hz: 0.40mA

Agency Approvals:



Nominal Current Rating	Part Number	Termination Line/Load	MINIMUM INSERTION LOSS - dB (50 ohm Circuit)						
			MODE	Frequency - MHz					
6A	F2300CA06	IEC/QC	Common Differential	.15	.50	1.0	5.0	10	30
								25 12	37 30

NOTE: Other combinations of terminals may be specified on special order.

Dimensions are in inches and millimeters unless otherwise specified. Values in parentheses are metric equivalents.



Curtis Industries
A Division of Powers Holdings, Inc.

1-800-657-0853

F2400/2500 RFI Filters



Features:

- Higher Performance Filters Designed for Common Mode and Differential Mode Applications
- 4X Greater Differential Mode Insertion Loss at 1 MHz than F2100/F2200 Series with No Increase in Physical Size
- Especially Suited for Use with Linear Power Supplies and FCC "A" Applications

F2400/2500 Simplified Schematic

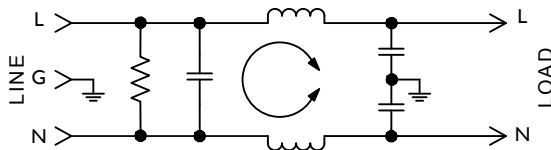

Specifications:

Rated Voltage: 250VAC Maximum - 50/60 Hz

Rated Current:	115VAC	250VAC
	3A	1.5A
	6A	3A
	10A	10A
	15A	10A

Current Overload: 6X for 8 seconds

Hi-Pot Test (1 min):

Line to Ground	1500VAC
Line to Line	1768VDC

Insulation Resistance: $9 \times 10^9 \Omega$ at 100VDC

Ambient Temperature: 40°C Max. at rated current

Humidity Range: 0% to 95% R.H.

Termination:

A: QC – Quick Connect
C: IEC Receptacle

Maximum Leakage Current:

Each Line to Ground	F2400/F2500
115VAC, 60Hz:	0.25mA
250VAC, 50Hz:	0.40mA

Agency Approvals:



Nominal Current Rating	Part Number	Termination Line/Load	MINIMUM INSERTION LOSS - dB (50 ohm Circuit)						
			MODE	Frequency - MHz					
				.15	.50	1.0	5.0	10	30
3A	F2400CA03 F2500CA03	IEC/QC IEC/QC	Common	22	35	40	46	50	50
			Differential	8	18	24	40	50	40
6A	F2400CA06 F2500CA06	IEC/QC IEC/QC	Common	15	24	31	42	45	50
			Differential	8	18	24	40	50	40
10/15A	F2400CA10 F2400CA15	IEC/QC IEC/QC	Common	4	10	13	28	35	40
			Differential	2	8	15	30	35	35

NOTE: Other combinations of terminals may be specified on special order.



F2400CA (3, 6, 10 and 15Amp) Dimensions

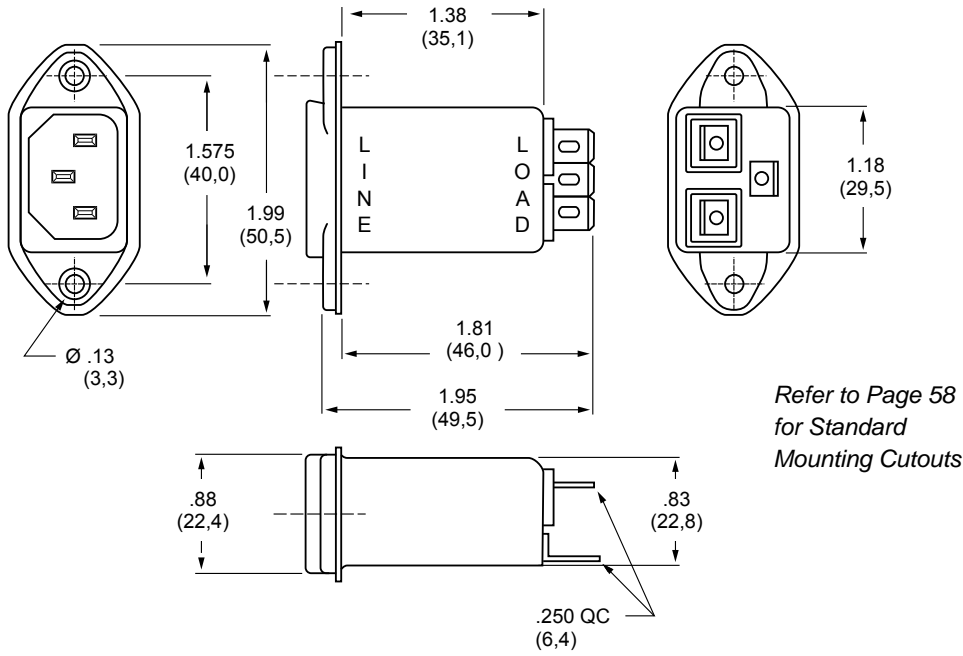

F2500CA (3 and 6Amp) Dimensions

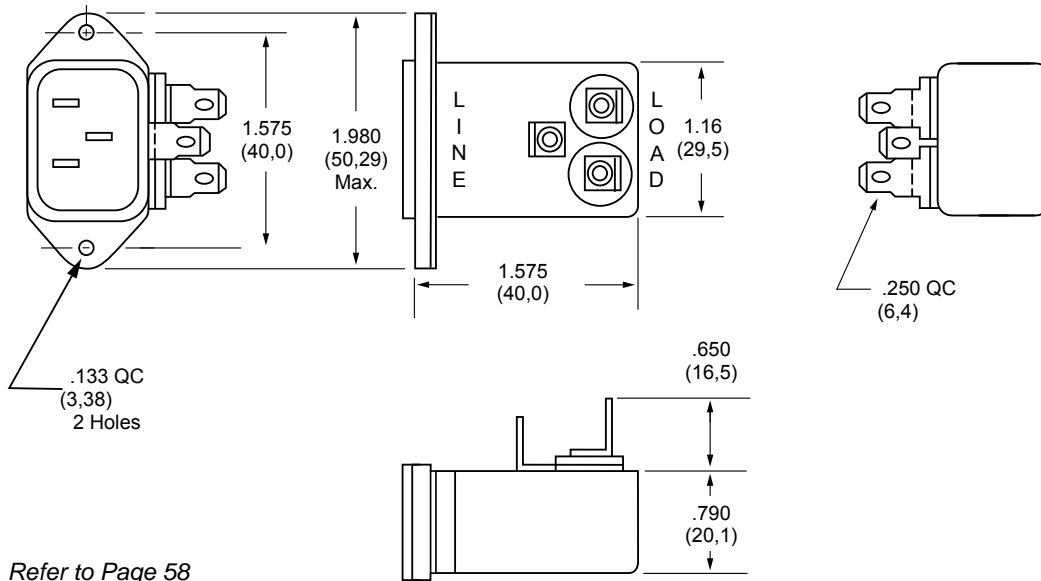

F2600 RFI Filters



Features:

- General Purpose “L-Type” Circuit Effective in Reducing Both Incoming and Outgoing Powerline Noise Levels in FCC “A” Applications
- Integral 5 X 20mm Single or Dual Fused IEC Connector
- Optional SST Switched IEC Connector
- All Series Available in Labor-Saving PC Mounted Case Style

Specifications:

Rated Voltage: 250VAC Maximum - 50/60 Hz

Rated Current: 115VAC 250VAC
 3A 3A
 6A 6A

Current Overload: 6X for 8 seconds

Hi-Pot Test (1 min):

Line to Ground 1500VAC
Line to Line 1768VDC

Insulation Resistance: 9 x 10⁹ Ω at 100VDC

Ambient Temperature: 40°C Max at rated current

Humidity Range: 0% to 95% R.H.

Termination:

- A: QC – Quick Connect
- F: Fused IEC
- J: Switched IEC
- P: PC – P.C. Board
- W: Dual Fused IEC

Maximum Leakage Current:

Each Line to Ground **F2600**
115VAC, 60Hz: 0.25mA
250VAC, 50Hz: 0.40mA

Agency Approvals:



F2600F Simplified Schematic

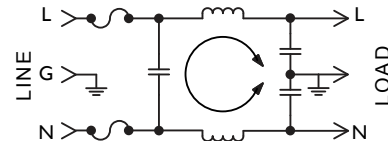

Nominal Current Rating	Part Number	Termination Line/Load	MINIMUM INSERTION LOSS - dB (50 ohm Circuit)						
			MODE	Frequency - MHz					
				.15	.50	1.0	5.0	10	30
3A	F2600FA03 F2600FP03	Fused IEC/QC Fused IEC/PC	Common	21	35	41	50	50	50
			Differential	8	18	24	40	50	40
6A	F2600FA06 F2600FP06	Fused IEC/QC Fused IEC/PC	Common	18	34	41	45	45	45
			Differential	8	18	24	40	50	50
3A	F2600WA03 F2600WP03	Dual Fused IEC/QC Dual Fused IEC/PC	Common	21	35	41	45	45	50
			Differential	8	18	24	40	50	40
6A	F2600WA06 F2600WP06	Dual Fused IEC/QC Dual Fused IEC/PC	Common	18	34	41	40	40	45
			Differential	8	18	24	40	50	50
3A	F2600JA03 F2600JP03	Switched IEC/QC Switched IEC/PC	Common	21	35	41	45	45	50
			Differential	8	18	24	40	50	40
6A	F2600JA06 F2600JP06	Switched IEC/QC Switched IEC/PC	Common	18	34	41	40	40	45
			Differential	8	18	24	40	50	50

NOTE: Other combinations of terminals may be specified on special order.



F2600FA (3 and 6Amp) Dimensions

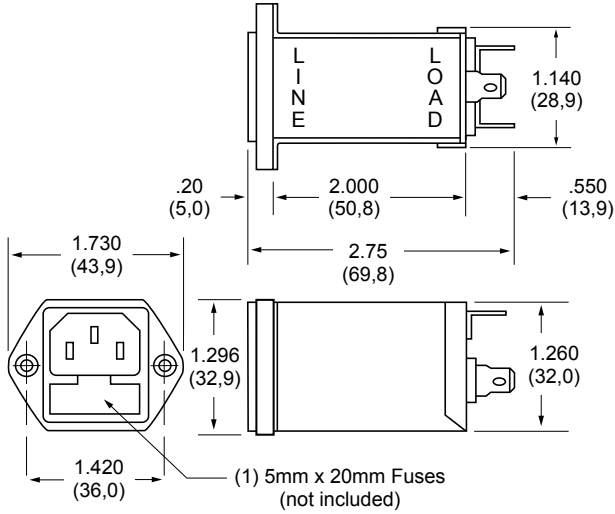

F2600FP (3 and 6Amp) Dimensions

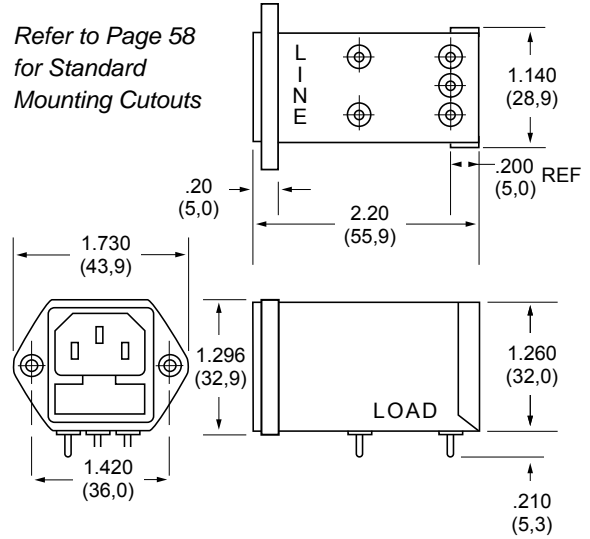

F2600WA (3 and 6Amp) Dimensions

F2600W Simplified Schematic

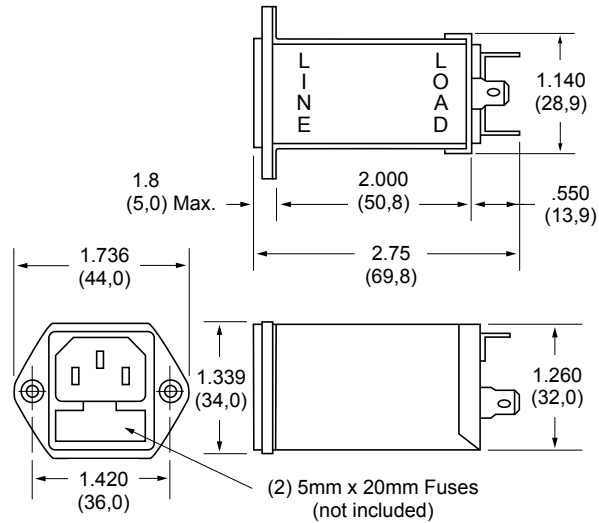
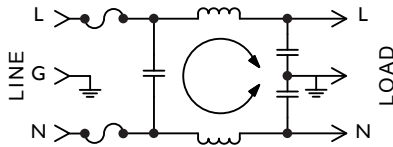

F2600JA (3 and 6Amp) Dimensions

F2600J Simplified Schematic

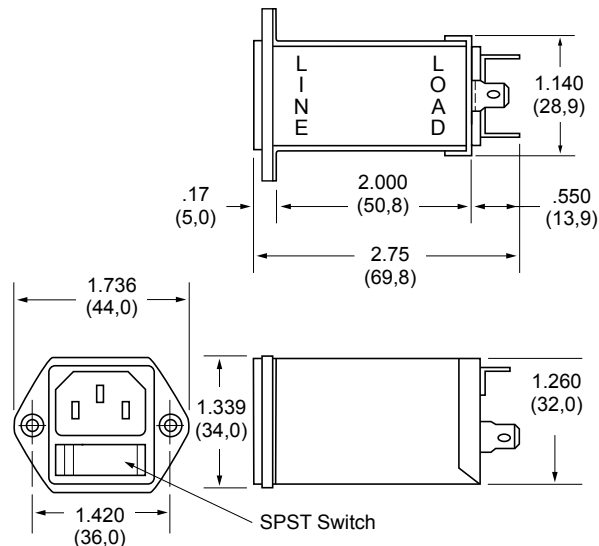
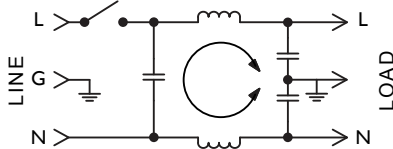

Dimensions are in inches and millimeters unless otherwise specified. Values in parentheses are metric equivalents.



F2700 RFI Filters

General Purpose Filtered Modules



Features:

- Designed for FCC "B" and VDE "B" Switching Power Supply Applications
- Very High Inductance Design with Differential Mode Choke to Provide Improved Performance Below 100KHz
- Compact, Space-Efficient Package Available in 3 and 6Amp Ratings
- Also Available with Integral Fused IEC Connector and "ON/OFF" Power Switch

POWER ENTRY MODULES

Specifications:

Rated Voltage: 250VAC Maximum - 50/60 Hz

Rated Current:

115VAC	250VAC
3A	2A
6A	4A

Current Overload: 6X for 8 seconds

Hi-Pot Test (1 min):

Line to Ground	1500VAC
Line to Line	1768VDC

Insulation Resistance: $9 \times 10^9 \Omega$ at 100VDC

Ambient Temperature: 40°C Max. at rated current

Humidity Range: 0% to 95% R.H.

Termination:

- A: QC – Quick Connect
- B: Wire
- C: IEC Receptacle
- F: Fused IEC

Maximum Leakage Current:

Each Line to Ground	F2700
115VAC, 60Hz:	0.25mA
250VAC, 50Hz:	0.40mA

Agency Approvals:



F2700 Without Switch Simplified Schematic

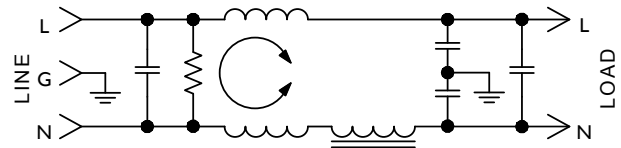

F2700 Without Switch Simplified Schematic (3Amp Only)

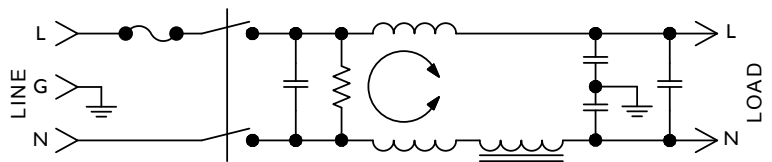

Nominal Current Rating	Part Number	Termination Line/Load	MINIMUM INSERTION LOSS - dB (50 ohm Circuit)										
			MODE	Frequency - MHz									
				.01	.02	.05	.15	.50	1.0	5.0	10	30	
3A	F2700AA03	QC/QC	Common	20	27	36	45	42	42	42	40	38	
	Differential	5	27	52	70	70	70	70	70	60	58		
3A	F2700CA03	IEC/QC Fused IEC/Wire	Common	20	27	36	45	42	42	42	40	38	
	Differential		5	27	52	70	70	70	70	60	58		
6A	F2700AA06	QC/QC	Common	10	18	28	39	42	45	45	45	45	
	Differential	5	20	48	70	70	70	70	70	70	65		

NOTE: Other combinations of terminals may be specified on special order.



F2700AA (3 and 6Amp) Dimensions

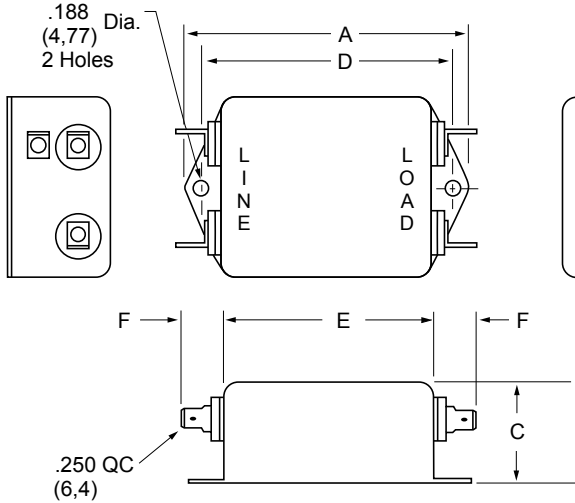

Amps	A	B	C	D	E	F
3A	3.315 (84,2)	2.000 (50,8)	1.500 (38,1)	2.940 (74,7)	2.500 (63,5)	.550 (14,0)
6A	4.440 (112,8)	2.250 (57,2)	1.750 (44,5)	4.063 (103,2)	3.620 (91,9)	.550 (14,0)

F2700FB03 (3Amp) Dimensions

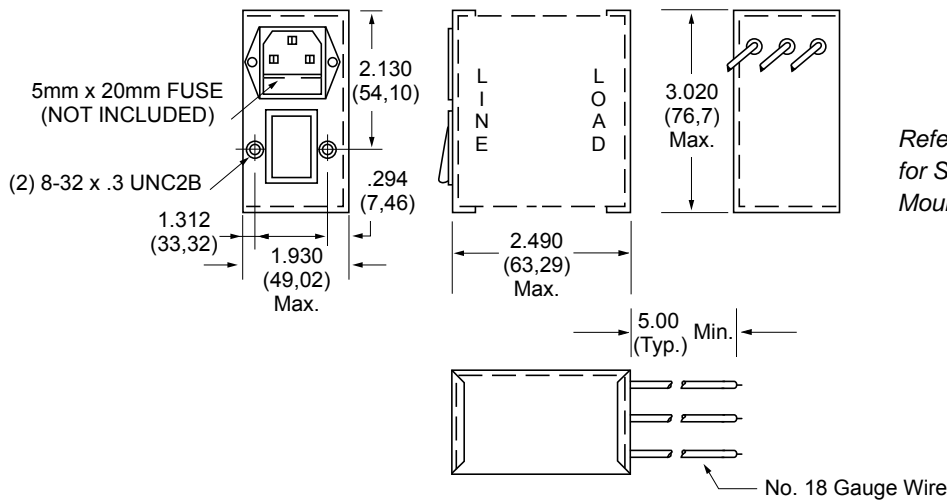

Refer to Page 58
for Standard
Mounting Cutouts

F2700CA (3 and 6Amp) Dimensions

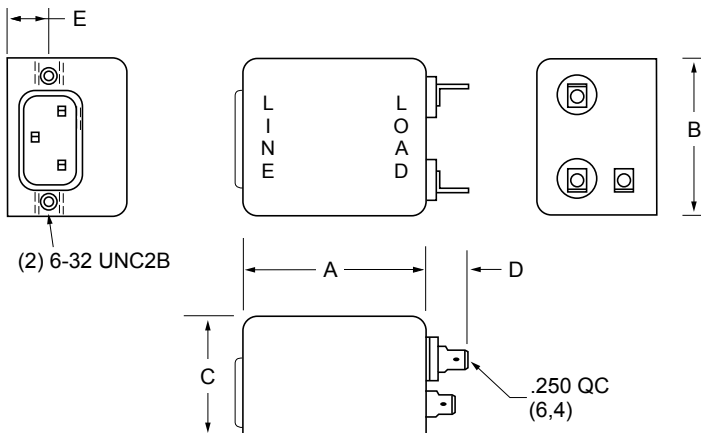

Refer to Page 58
for Standard
Mounting Cutouts

Amps	A	B	C	D	E
3A	2.880 (73,2)	2.125 (54,0)	1.719 (43,6)	.550 (14,0)	.575 (14,6)
6A	3.750 (95,2)	2.250 (57,1)	1.750 (44,4)	.550 (14,0)	.640 (16,29)



PE7/PE8 Series

Combination



Specifications:

Rated Voltage: 250VAC Maximum - 50/60 Hz

Rated Current: 115VAC 250VAC
 3A 3A
 6A 6A

Current Overload: 6X for 8 Seconds

Hi-Pot Test (1 min):

Line to Ground 1500VAC
 Line to Line 1768VDC

Insulation Resistance: $9 \times 10^9 \Omega$ at 100VDC

Ambient Temperature: 40°C Max. at Rated Current

Humidity Range: 0% to 95% R.H.

Termination:

- IEC Receptacle
- Wire Wrap/Solder

Maximum Leakage Current:

Each Line to Ground	PE7, PE 8
115VAC, 60Hz:	0.25mA
250VAC, 50Hz:	0.40mA

Voltage Select Card: Installed in 120VAC position unless otherwise specified

Agency Approvals:



Refer to Page 55 for Ordering Instructions

Features:

- RFI Filter Module Combines IEC Connector, Fusing, and Voltage Select Features in One Unit
- PE7 Series Filters Provide 20% More Differential Mode Attenuation Than Comparable Units
- Accepts Either U.S. or European Standard Fuse Sizes

PE7 Series Simplified Schematic

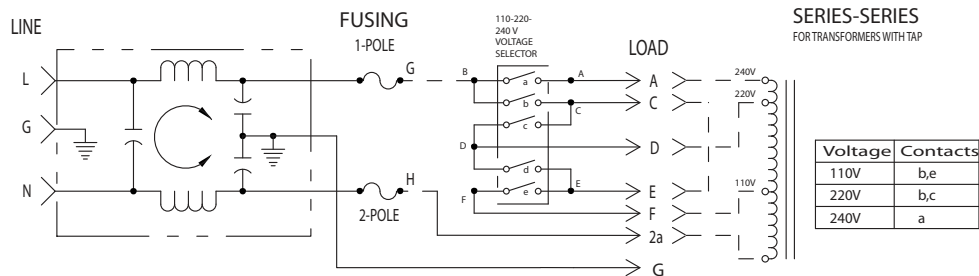

Nominal Current Rating	Part Number	Termination Line/Load	MINIMUM INSERTION LOSS - dB (50 ohm Circuit)						
			MODE	Frequency - MHz					
				.15	.50	1.0	5.0	10	30
3A	PE7XXX03	IEC/Solder Tabs	Common	18	24	30	45	45	50
	Differential		8	18	24	46	50	40	
6A	PE7XXX06	IEC/Solder Tabs	Common	10	19	24	39	44	50
	Differential		8	18	24	39	40	40	



PE7 Series Simplified Schematic

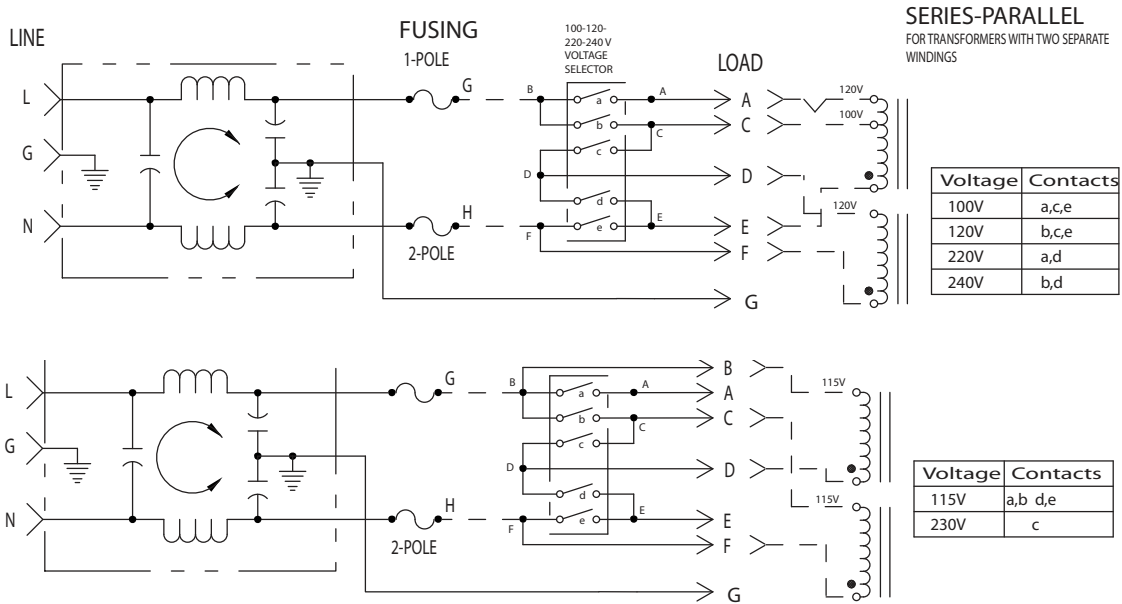

PE8 Series Simplified Schematic

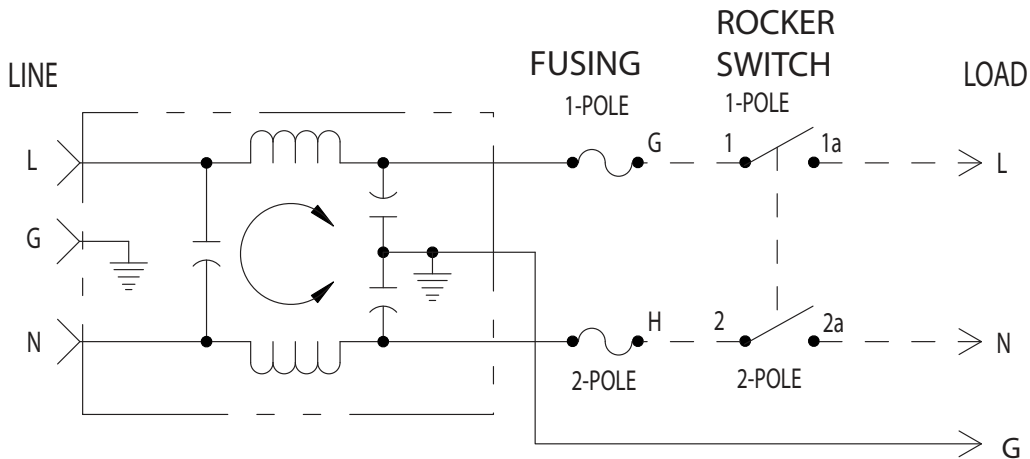

PE7/PE8 Series *(continued)*

PE7/PE8 Snap-Mount Series (3 and 6Amp) Dimensions

Refer to Page 55
for Standard
Mounting Cutouts

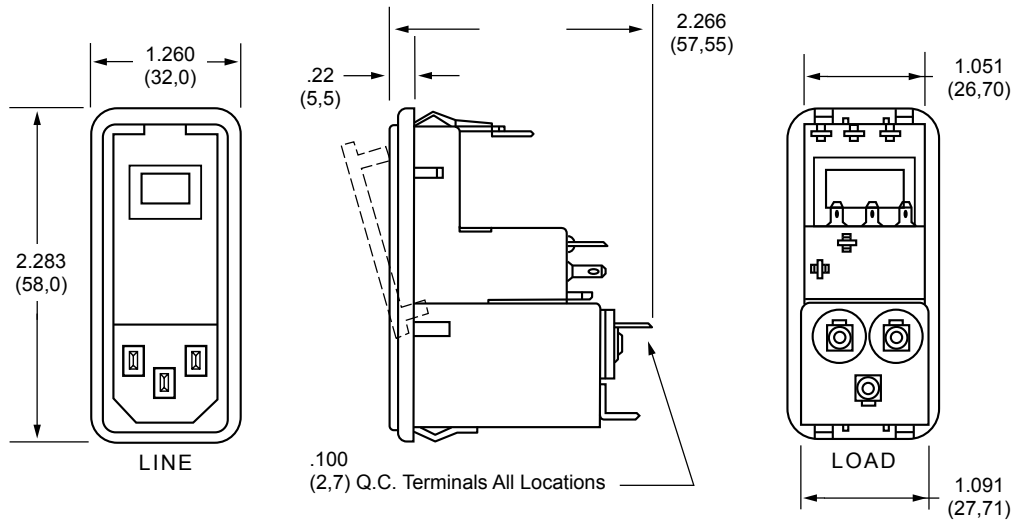

Combination

PE7/PE8 Screw-Mount Series (3 and 6Amp) Dimensions

Refer to Page 55
for Standard
Mounting Cutouts

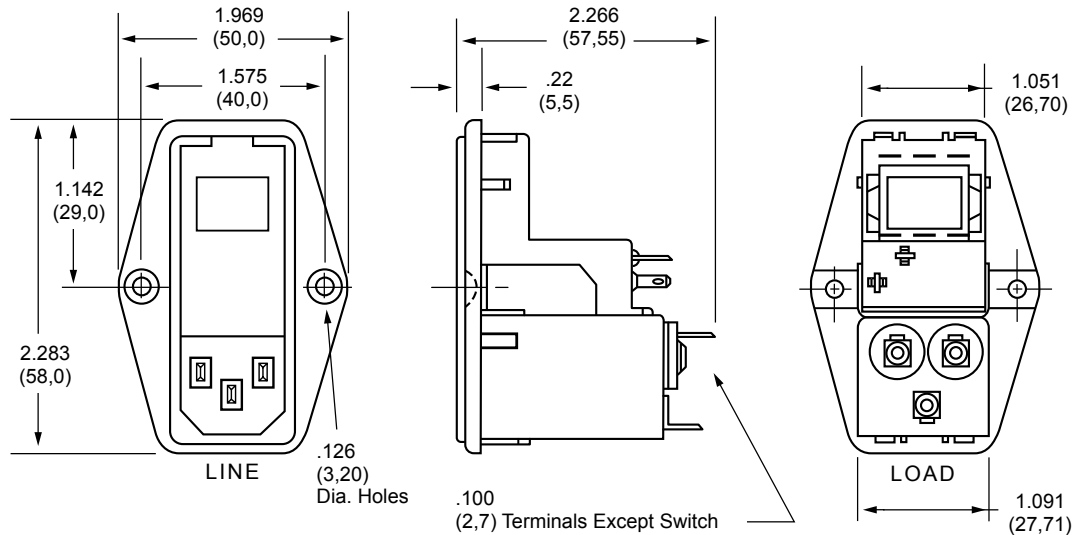

POWER ENTRY MODULES



How to Order

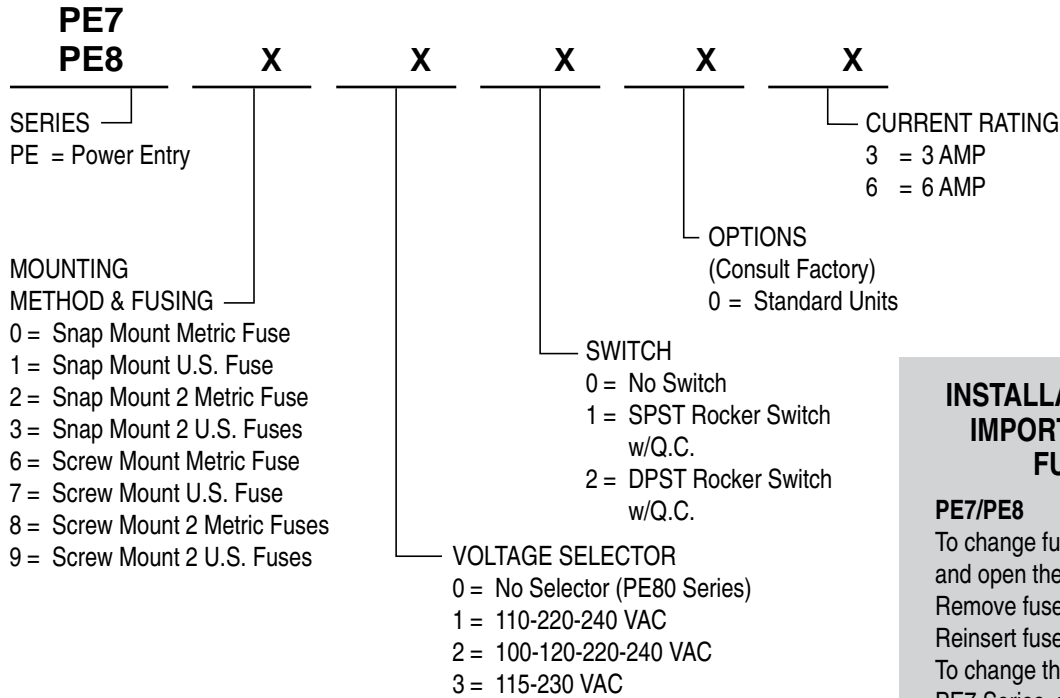

INSTALLATION INSTRUCTION IMPORTANT – CHANGING FUSE/VOLTAGE

PE7/PE8

To change fuse, remove power cord and open the front cover on the module. Remove fuse holder and replace fuse. Reinsert fuse holder and close cover. To change the operating voltage on the PE7 Series, remove the power cord and open front cover. Rotate voltage select wheel until desired voltage appears in window of cover.

- Filter shipped without fuse.

Always use caution when selecting and changing fuses and voltage requirements. Curtis Industries is not responsible for malfunction due to improper installation/selection of fuse and/or voltage select.

PE7/PE8 Snap-Mount Series

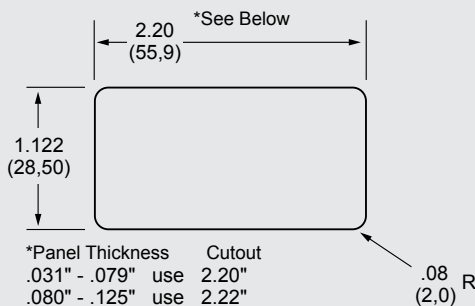

PE7/PE8 Screw Mount Series

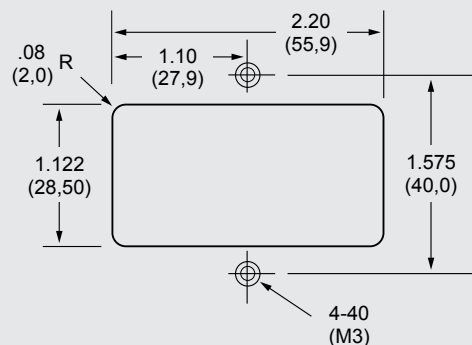

PE1 Series



Specifications:

Rated Voltage: 250VAC Maximum - 50/60 Hz

Rated Current: 115VAC 250VAC
10A 10A

Current Overload: 6X for 8 seconds

Hi-Pot Test (1 min):

Line to Ground 1500VAC
Line to Line 2250VDC

Insulation Resistance: $9 \times 10^9 \Omega$ at 100VDC

Ambient Temperature: 40°C Max at rated current

Humidity Range: 0% to 95% R.H.

Termination:

- QC – Quick Connect
- IEC Receptacle

Maximum Leakage Current:

Each Line to Ground	PE1	PE1-PO
115VAC, 60Hz:	0.25mA	0.4mA
250VAC, 50Hz:	0.40mA	.75mA

Voltage Select Card: Installed in 120VAC position unless otherwise specified

Agency Approvals:



Features:

- RFI Filter Module Combines IEC Connector, Fusing, Optional Voltage Select and On/Off Switch into a Single, Space-Efficient Assembly
- Enhanced Low Frequency Response with No Resonant Peaks
- Fully Shielded for Radiative Noise Control
- Accepts Either U.S. or European Standard Fuse Sizes. Dual or Single Power Line Fusing

PE1 Series Simplified Schematic without Voltage Selector

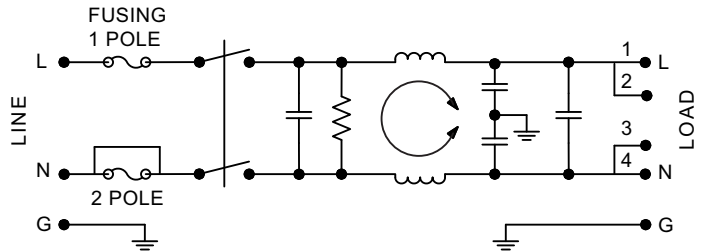

PE1 Series Simplified Schematic with Voltage Selector

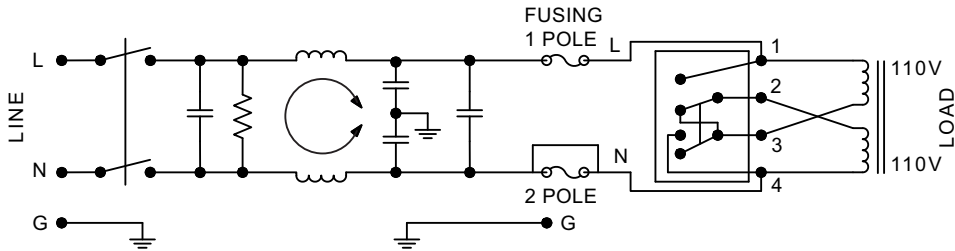

Nominal Current Rating	Part Number	Termination Line/Load	MINIMUM INSERTION LOSS - dB (50 ohm Circuit)							
			MODE	Frequency - MHz						
				.05	.15	.50	.10	5.0	10	30
10A	PE1XXX10	IEC/QC	Common	10	20	30	38	45	50	50
			Differential	10	20	30	35	55	60	55
10A	PE1XXXP0	IEC/QC	Common	13	24	33	38	48	54	54
			Differential	10	20	30	35	65	65	55

NOTE: Other combinations of terminals may be specified on special order.



PE1
(10Amp)
Dimensions

Refer to Standard
Mounting Cutouts on
Page 58

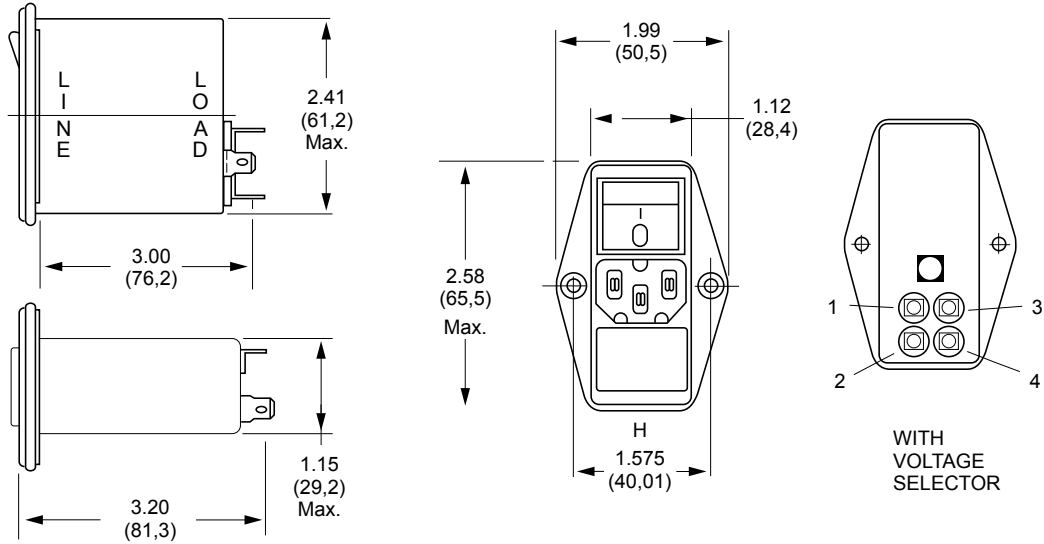

How to Order

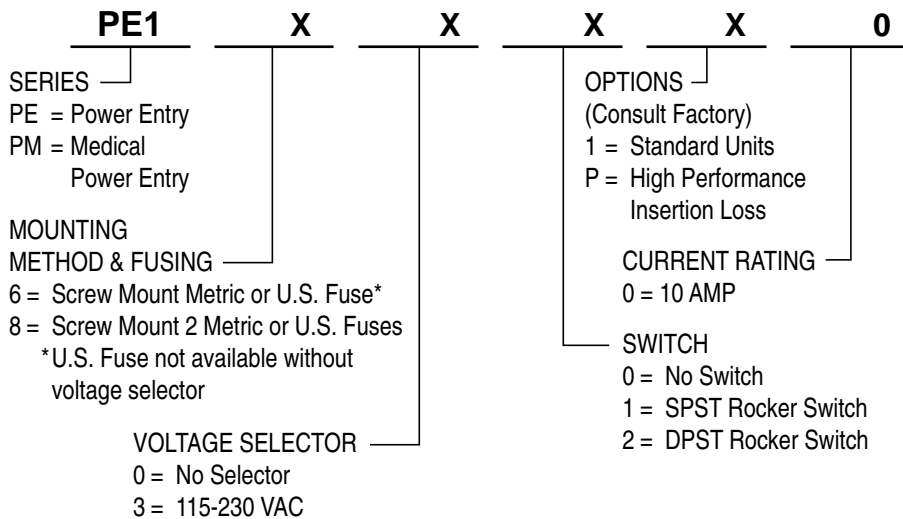

**INSTALLATION INSTRUCTION
IMPORTANT – CHANGING
FUSE/VOLTAGE**

PE1

To change fuse, remove power cord. Remove voltage selector and replace fuse. Reinsert fuse holder. To change the operating voltage on the PE1 Series, remove the power cord and rotate fuse holder block until desired voltage aligns with the mark on the module housing.

- **Filter shipped without fuse.**

Always use caution when selecting and changing fuses and voltage requirements. Curtis Industries is not responsible for malfunction due to improper installation/selection of fuse and/or voltage select.



Standard Mounting Cutouts

F2199CA, F2200CA, F2300CA, F2400CA, F2500CA, F2700CA, F3100CA, F3200CA, F3400CA, F3500CA

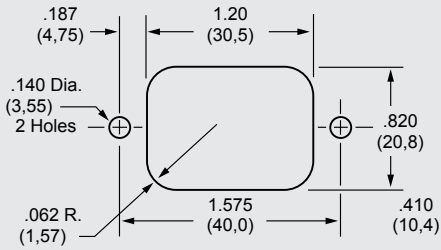

Back Mounting

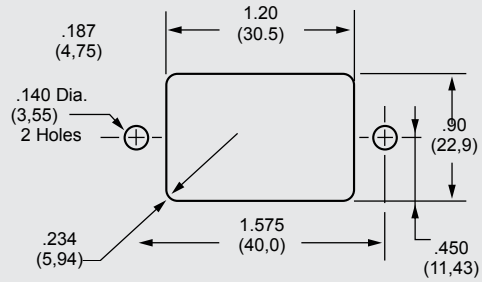

Front Mounting

F2600FP, F3300FP

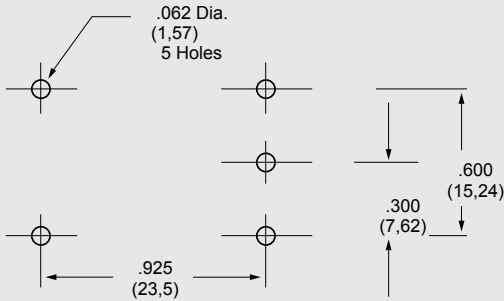

F2600, F3300

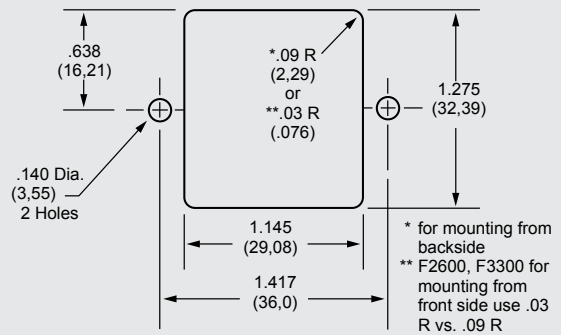

POWER ENTRY MODULES

F2700FB

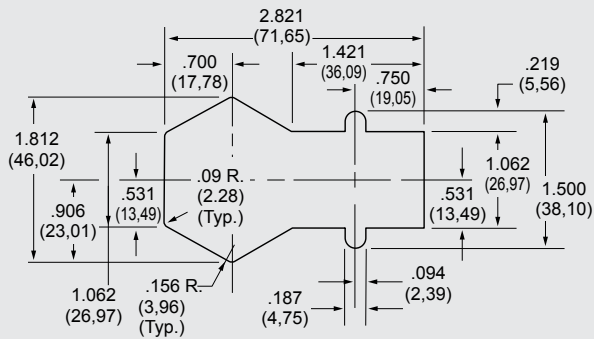

PE1 Screw Mount Series

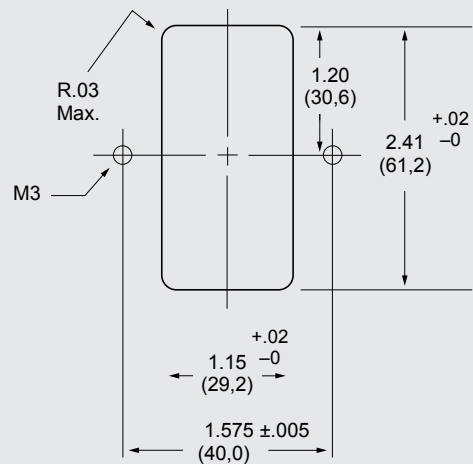

THREE-PHASE FILTERS]

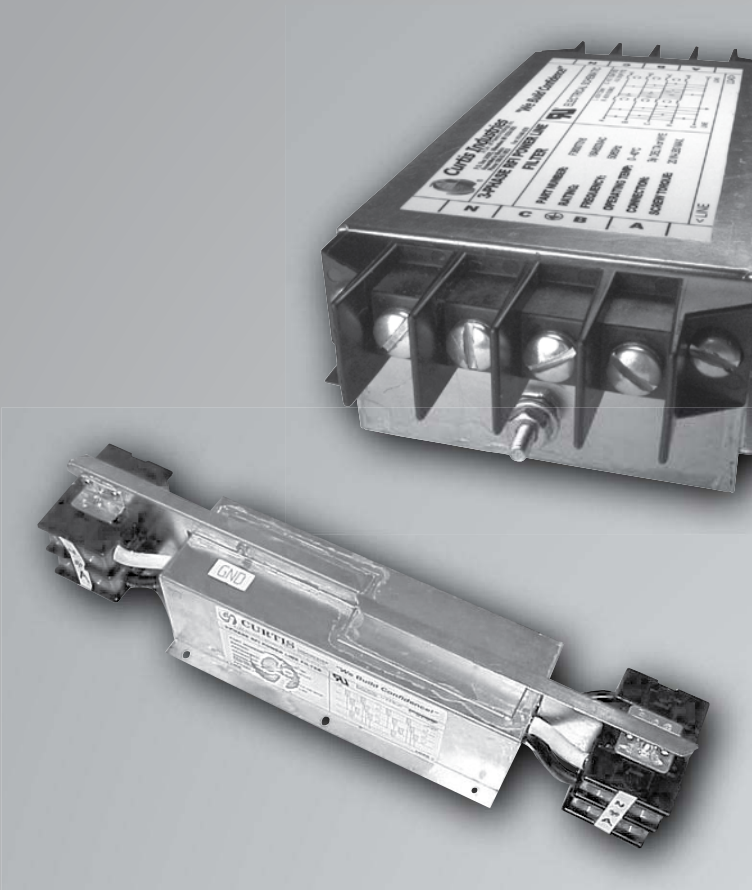

Series F3480/F3600

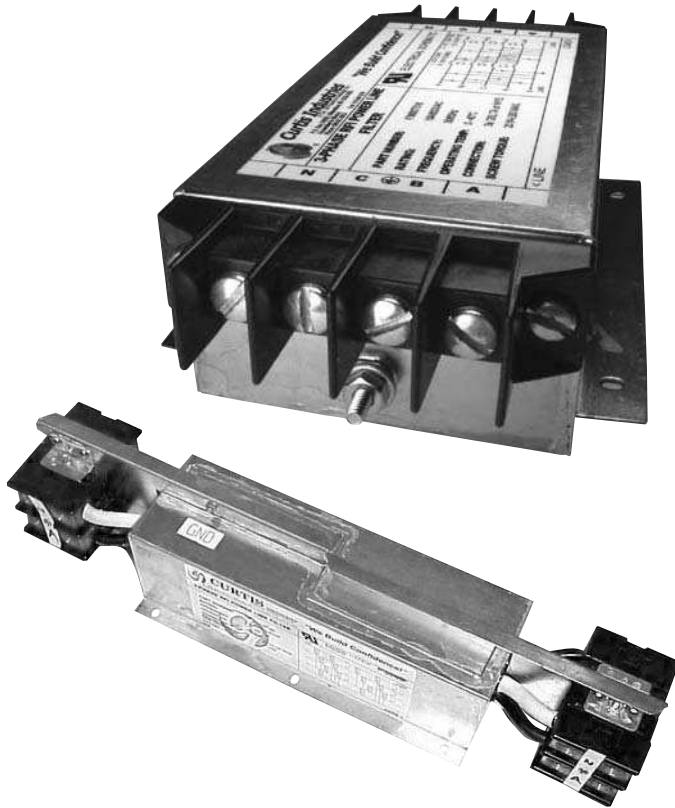

Specifications:

Rated Voltage: 480 VAC - 50/60 Hz
600 VAC - 50/60 Hz

Rated Current: 480 VAC - 9A to 608A
600 VAC - 8A to 600A

Current Overload: 6X for 8 seconds

Hi-Pot Test (1 min):	480VAC	600VAC
Line to Ground	2210 VDC	3150 VDC
Line to Line	2780 VDC	3150 VDC

Insulation Resistance: 1000 MΩ min. at 250 VDC

Ambient Temperature: 0°C to 40°C (32°F to 104°F)

Humidity Range: 0% to 95% R.H.

Termination:

- Wire
- Terminal Blocks
- Pressure Terminal Blocks

Weight: 3 to 65lbs (1.36 to 29.50kg)

Agency Approvals:



Designed to attenuate conducted interference in a small package providing excellent insertion loss, the F3480/F3600 series filters will provide effective EMC solutions up to 600A at 600VAC and power applications up to 360kVA. With effective noise suppression in the critical 150kHz-30MHz range, this advanced 2-stage filter line will support both Delta and Wye connected loads. Curtis three phase filters are designed to provide EMC solutions in many applications such as:

- Motor
- Motor Control Centers
- Facility Filters
- Uninterruptible Power Supplies
- Power Conditioning Units
- Laser Welders
- Automated Test Equipment
- Robotics
- CNC Machinery
- Elevators
- Industrial Ovens

F3480 Simplified Schematic

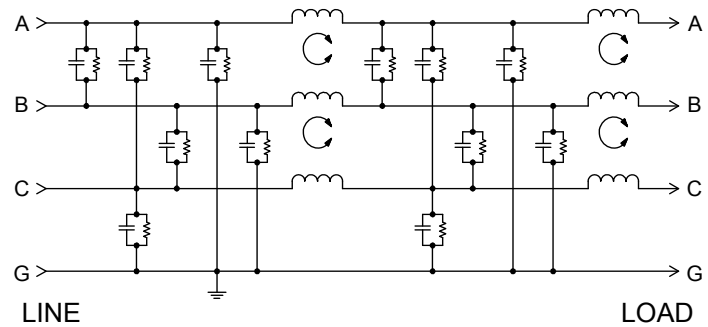

F3600 Simplified Schematic

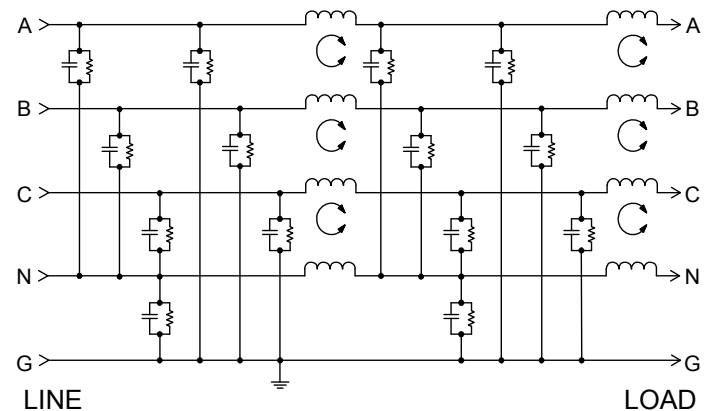

3-Phase Power Line Filters

Ordering Information:

F3600 T 600

3-Phase Series:
 F3480 = 480 VAC
 F3600 = 600 VAC

T = Terminal Blocks
 B = Wire Leads
 A = .250 Q.C. Terminal
 (8 - 50A Only)

Current Rating 008 - 608
 (Refer to Charts)

F3480 Series - 480 VAC																
Rated Current (Amps)	Part Number	Maximum Leakage Each L/G (250V, 60Hz)	Minimum Insertion Loss (dB)						Dimensions (Inches)							
									A	B	C	D	E	F	G	
608A	F3480T608	140mA	Frequency (MHz)						18.75	5.25	5.93	41.25	16.00	8.00	.28 x .40	
	.15 .5 1 5 10 30															
	CM		60	70	70	60	45	30								
	F3480B608		DM	30	40	40	35	30	20	18.75	5.25	4.50	--			
322A	F3480T322	90mA	Frequency (MHz)						10.50	5.25	4.63	23.50	8.00	4.00	.28 x .40	
	.15 .5 1 5 10 30															
	CM		60	70	70	65	55	45								
	F3480B322		DM	30	40	40	40	35	20	10.50	5.25	4.50	--			
185A	F3480T185	90mA	Frequency (MHz)						11.25	4.12	4.25	20.25	10.00	5.00	.20 x .30	
	.15 .5 1 5 10 30															
	CM		60	70	70	65	55	45								
	F3480B185		DM	30	35	35	45	40	30	11.25	4.12	3.50	--			
135A	F3480T136	80mA	Frequency (MHz)						8.50	4.12	4.25	16.00	7.00	3.50	.20 x .30	
	.15 .5 1 5 10 30															
	CM		60	65	70	60	50	40								
	F3480B136		DM	25	35	45	30	30	20	8.50	4.12	3.50	--			
112A	F3480T112	80mA	Frequency (MHz)						8.50	4.12	4.25	16.00	7.00	3.50	.20 x .30	
	.15 .5 1 5 10 30															
	CM		60	65	70	60	50	40								
	F3480B112		DM	25	35	45	30	30	20	8.50	4.12	3.50	--			
80A	F3480T080	30mA	Frequency (MHz)						8.50	4.12	4.25	16.00	7.00	3.50	.20 x .30	
	.15 .5 1 5 10 30															
	CM		60	70	70	65	55	45								
	F3480B080		DM	15	25	45	40	40	30	8.50	4.12	3.50	--			
60A	F3480T060	30mA	Frequency (MHz)						8.50	4.12	4.25	16.00	7.00	3.50	.20 x .30	
	.15 .5 1 5 10 30															
	CM		60	70	70	65	55	45								
	F3480B060		DM	15	25	45	40	40	30	8.50	4.12	3.50	--			
50A	F3480A050	15mA	Frequency (MHz)						8.00	5.12	2.25	--	5.00	--	.19 x .25	
	.15 .5 1 5 10 30															
	CM		60	75	80	75	70	50								
	F3480B050		DM	10	40	50	50	50	40	8.00	5.12	2.25	10.10			
	F3480T050		Frequency (MHz)													
32A	F3480A032	7mA	Frequency (MHz)						8.00	5.12	2.25	--	5.00	--	.19 x .25	
	.15 .5 1 5 10 30															
	CM		60	70	80	75	65	45								
	F3480B032		DM	10	45	50	50	50	40	8.00	5.12	2.25	10.10			
	F3480T032		Frequency (MHz)													
16A	F3480A016	3mA	Frequency (MHz)						6.00	3.88	2.00	--	4.00	--	.16 x .20	
	.15 .5 1 5 10 30															
	CM		50	70	80	75	65	50								
	F3480B016		DM	10	50	50	40	40	40	6.00	3.88	2.00	10.10			
	F3480T016		Frequency (MHz)													
9A	F3480A009	3mA	Frequency (MHz)						6.00	3.88	2.00	--	4.00	--	.16 x .20	
	.15 .5 1 5 10 30															
	CM		60	80	80	70	60	50								
	F3480B009		DM	30	45	50	50	50	50	6.00	3.88	2.00	10.10			
	F3480T009		Frequency (MHz)													

THREE-PHASE FILTERS

Dimensions are in inches and millimeters unless otherwise specified. Values in parentheses are metric equivalents.



Series F3480/F3600

F3480B & F3600B Dimensions

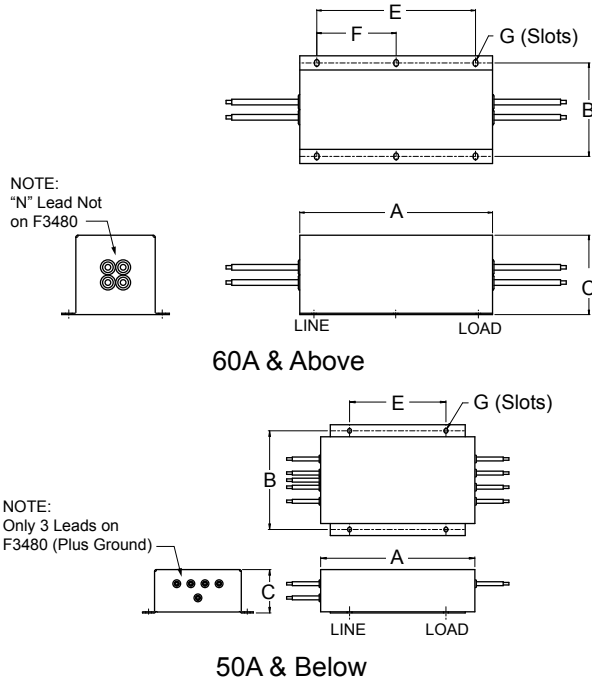

F3480T & F3600T Dimensions

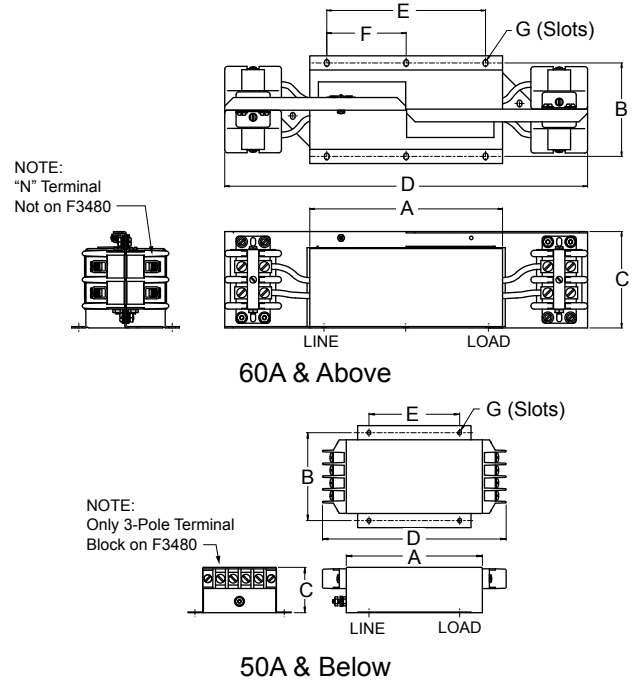

F3600 Series - 600 VAC

Rated Current (Amps)	Part Number	Maximum Leakage Each L/G (250V, 60Hz)	Minimum Insertion Loss (dB)							Dimensions (Inches)						
			Frequency (MHz)							A	B	C	D	E	F	G
600A	F3600T600	120mA	Frequency (MHz)							18.75	5.25	5.93	41.25	16.00	8.00	.28 x .40
	CM		60	60	50	50	40	30								
	DM		20	35	35	30	25	20								
300A	F3600T300	60mA	Frequency (MHz)							10.50	5.25	5.93	26.50	8.00	4.00	.28 x .40
	CM		60	60	50	50	40	30								
	DM		25	30	35	45	30	20								
180A	F3600T180	60mA	Frequency (MHz)							11.25	4.12	4.25	20.25	10.00	5.00	.20 x .30
	CM		60	60	60	60	50	40								
	DM		20	30	35	45	40	30								
80A	F3600T080	30mA	Frequency (MHz)							8.50	4.12	4.25	16.00	7.00	3.50	.20 x .30
	CM		60	60	60	60	50	40								
	DM		15	25	25	40	40	30								
45A	F3600A045	10mA	Frequency (MHz)							8.00	5.12	2.25	--	5.00	--	.19 x .25
	CM		60	60	80	70	60	45								
	DM		10	10	15	50	40	30								
25A	F3600A025	8mA	Frequency (MHz)							8.00	5.12	2.25	--	5.00	--	.19 x .25
	CM		60	60	80	70	60	45								
	DM		5	5	30	50	40	30								
16A	F3600A016	4mA	Frequency (MHz)							6.00	3.88	2.00	--	4.00	--	.16 x .20
	CM		50	70	80	70	60	45								
	DM		5	5	35	40	40	40								
8A	F3600A008	4mA	Frequency (MHz)							6.00	3.88	2.00	--	4.00	--	.16 x .20
	CM		60	70	80	70	60	45								
	DM		5	10	50	40	40	40								



DC FILTERS]

General Purpose High Performance

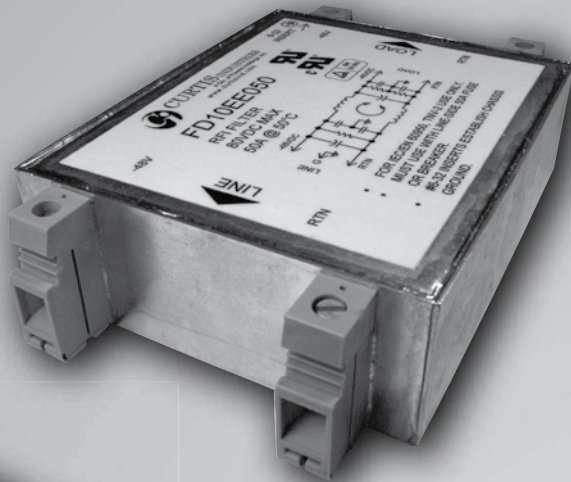

FD Series Filters

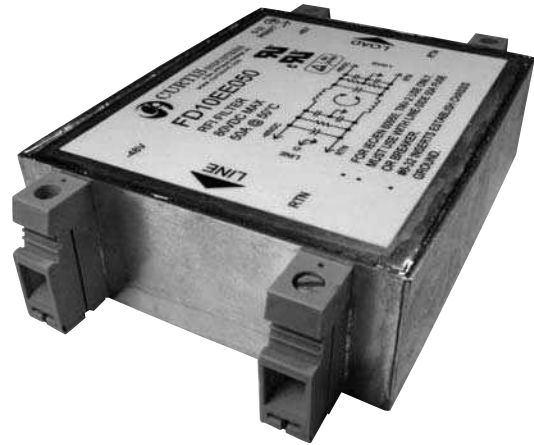

The FD Series of DC filters are designed as a general purpose line of filters for DC applications. They are designed to comply with UL/EN 60950 and UL 1459, CISPER 22 and Telecordia (Bellcore) GR-1089 at 25Amps and above. These filters are available with and without circuit breakers for additional protection.

The FD Series is a compact size that can filter up to 300MHz ideally suited for the telecom-datacom market. The FD0 Series is available from 6Amps to 100Amps in the smallest, economical package. The FD02 is a high frequency filter up to 3GHz (3,000MHz) in a compact package.

These filters are ideally used in communications and central office equipment.

- Power Supplies for Communications Equipment
- Network Routing Equipment
- Switching Equipment
- Base Stations
- Modems
- Services
- Ethernet Hubs



Specifications:

Rated Voltage: 80VDC Maximum

Rated Current: 6A
10A
20A
25A
50A
75A
100A

Current Overload: 6X for 8 seconds

Hi-Pot Rating (1 min):

Line to Ground 1060VDC
Line to Line 100VDC

Insulation Resistance: 1000 MΩ at 80VDC

Ambient Temperature: 0°C to 55°C (32°F to 131°F)

Humidity Range: 0% to 95% R.H.

Termination: See Chart at Right

Wire Leads: 18AWG 6A to 20A (FD0)
(FD0 25Amp to 100Amp not available with wire leads)
10AWG 30Amp (FD1, FD2, FD3)
6AWG 50Amp
4AWG 75Amp & 100Amp

Agency Approvals:

6Amp to 20Amp



25Amp to 100Amp

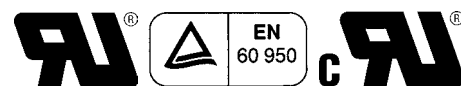

General Purpose

DC FILTERS



Power Line Filter Selection Guide

FD00 & FD02 SERIES

FILTER Part Number	Current Rating (Amps)	Termination		
		Quick Connects	Wire Leads	Studs
FD00AA006	6	X		
FD00BB006	6		X	
FD00DD006	6			X
FD00AA010	10	X		
FD00BB010	10		X	
FD00DD010	10			X
FD00AA020	20	X		
FD00DD020	20			X
FD00BD025	25		X	X
FD00DD025	25			X
FD00BD050	50		X	X
FD00DD050	50			X
FD00BD075	75		X	X
FD00DD075	75			X
FD00BD100	100		X	X
FD00DD100	100			X
FD02BD025	25		X	X
FD02DD025	25			X
FD02DD050	50			X
FD02BD050	50		X	X
FD02DD075	75			X
FD02BD075	75		X	X
FD02DD100	100			X
FD02BD100	100		X	X

FD1, FD2, FD3 SERIES

FILTER Part Number	Current Rating (Amps)	Disconnect Type			Termination			
		Single Pole Rocker Breaker	Double Pole Rocker Breaker	Double Pole Handle Breaker	Wire Leads	High Current Connector	Euro Connector	Dual Stud T-Block
FD10BB030	30				X			
FD10EE030	30						X	
FD10BB050	50				X			
FD10EE050	50						X	
FD10BB075	75				X			
FD10BB100	100				X			
FD20B_ _ _	30, 50, or 80				X			
FD20E_ _ _							X	
FD20R_ _ _		X						X
FD20D_ _ _			X					X
FD20H_ _ _				X				X
FD20_B_ _ _						X		
FD20_C_ _ _							X	
FD20_E_ _ _								X
FD20_T_ _ _								X
FD30B_ _ _		30, 50, 75, or 100				X		
FD30E_ _ _							X	
FD30R_ _ _	X							X
FD30D_ _ _			X					X
FD30H_ _ _				X				X
FD30_B_ _ _						X		
FD30_C_ _ _							X	
FD30_E_ _ _								X
FD30_T_ _ _								X

General Purpose

DC FILTERS

Dimensions are in inches and millimeters unless otherwise specified. Values in parentheses are metric equivalents.



FD Series Filters

How to Order

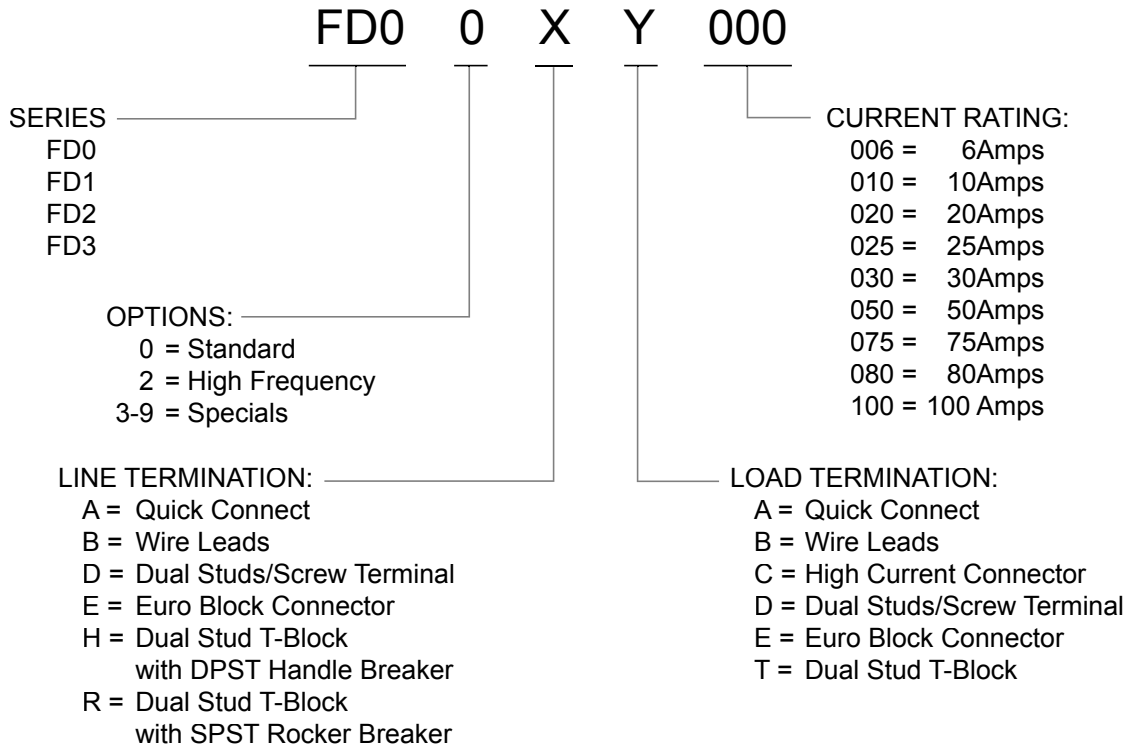

NOTE: Not all terminations are available in all models.

General Purpose

DC FILTERS

Part Number	TYPICAL INSERTION LOSS - dB (50 ohm Circuit)													
	MODE	Frequency - MHz												
		.01	.03	.10	.15	.50	1.0	5.0	10	30	100	300	1000	3000
FD00XX006 FD00XX010 FD00XX020	Common Differential	-	-	-	10	22	30	42	47	40	-	-	-	-
FD00XX025 FD00XX050 FD00XX075 FD00XX100	Common Differential	-	-	-	22	50	60	50	45	40	-	-	-	-
FD02XX025 FD02XX050 FD02XX100	Common Differential	5 40	5 45	35 45	45 45	60 48	60 50	55 45	55 55	50 48	40 45	10 15	20 58	25 40
FD10XX030 FD10XX050 FD10XX075 FD10XX100	Common Differential	5 55	15 60	48 70	60 70	65 70	65 65	60 70	60 60	55 50	25 35	25 15	-	-
FD20XX030 FD20XX050 FD20XX080	Common Differential	5 55	15 65	48 70	60 65	70 60	70 65	70 55	60 50	55 45	-	-	-	-
FD30XX030 FD30XX050 FD30XX075 FD30XX100	Common Differential	12 50	20 60	44 70	60 70	60 70	60 70	60 55	60 70	55 60	-	-	-	-



FD00 Filters

FD00AA (6, 10 and 20Amp) Dimensions

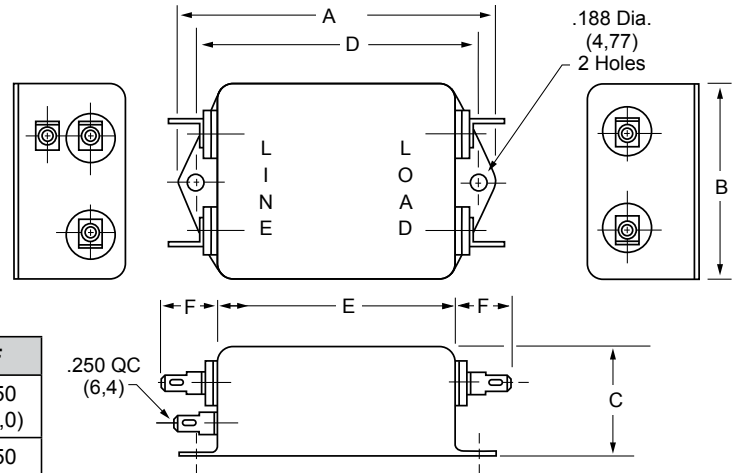
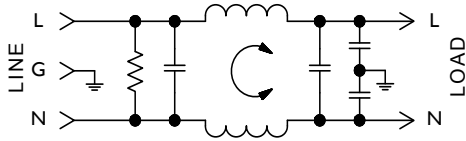

Amps	A	B	C	D	E	F
6A	3.312 (84,1)	2.000 (50,8)	1.125 (28,5)	2.940 (74,7)	2.500 (63,5)	.550 (14,0)
10A	3.312 (84,1)	2.000 (50,8)	1.500 (38,2)	2.940 (74,7)	2.500 (63,5)	.550 (14,0)
20A	See FD00DD below for Case Dimensions					

FD00BB

(6 and 10Amp) Dimensions

Amps	A	B	C	D	E
6A	3.312 (84,1)	2.000 (50,8)	1.125 (28,5)	2.940 (74,7)	2.500 (50,8)
10A	3.312 (84,1)	2.000 (50,8)	1.500 (38,1)	2.940 (74,70)	2.500 (50,8)

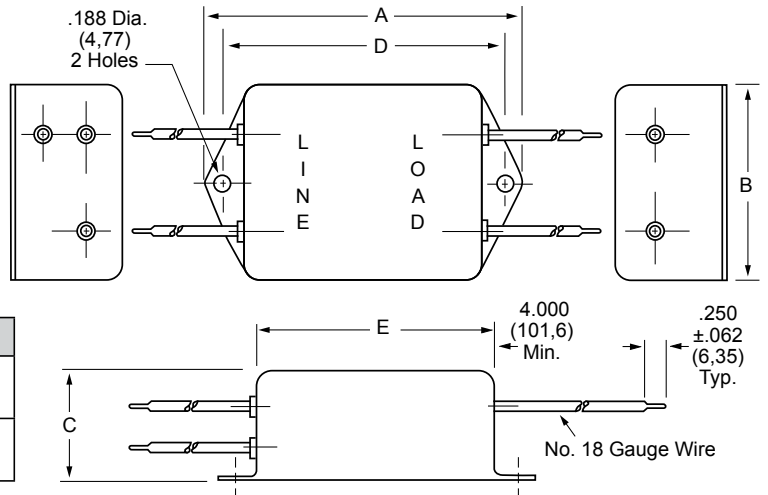

FD00DD (20Amp) Dimensions

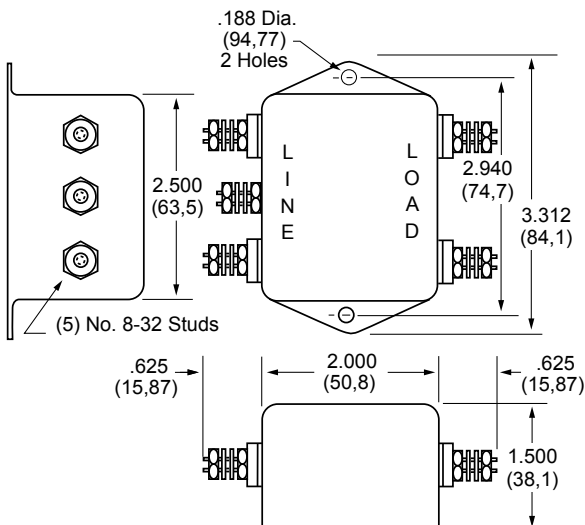

Dimensions are in inches and millimeters unless otherwise specified. Values in parentheses are metric equivalents.



Curtis Industries
A Division of Powers Holdings, Inc.

1-800-657-0853

67

General Purpose

DC FILTERS

FD00 & FD02 Filters

FD00DD (25, 50, 75 and 100Amp) Dimensions

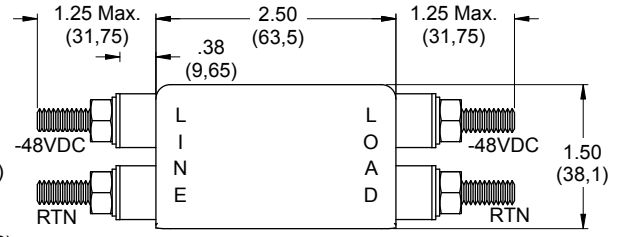
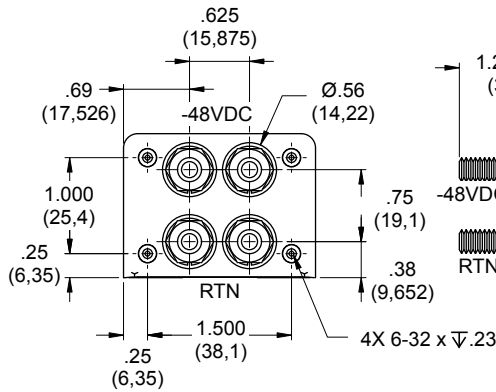
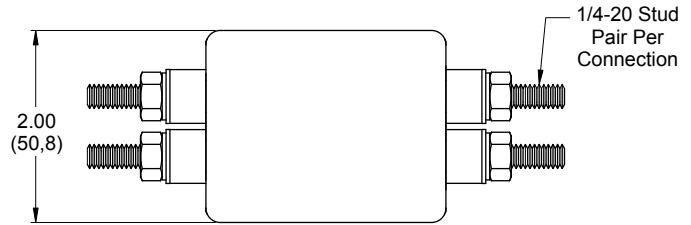
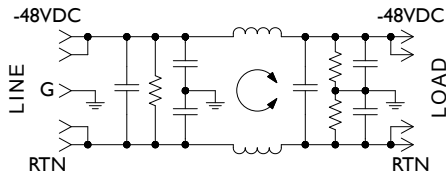

FD02DD (25, 50 and 100Amp) Dimensions

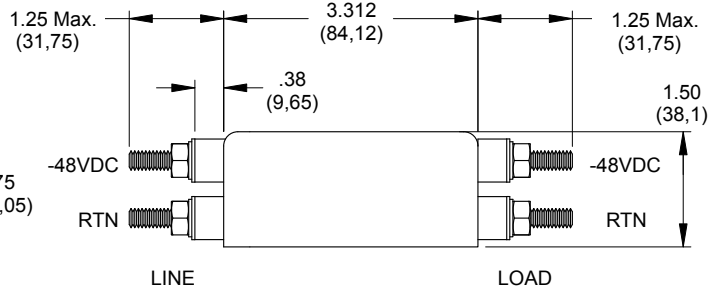
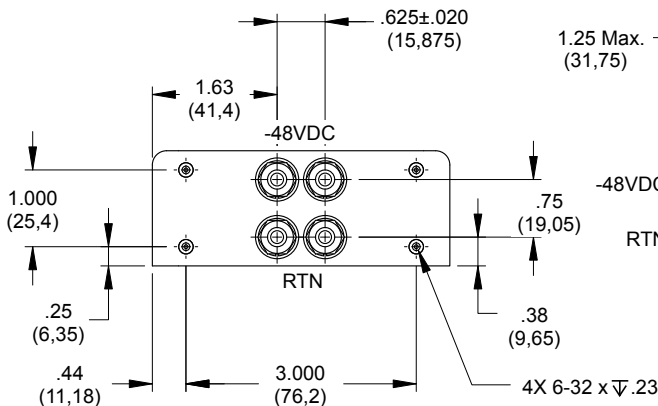
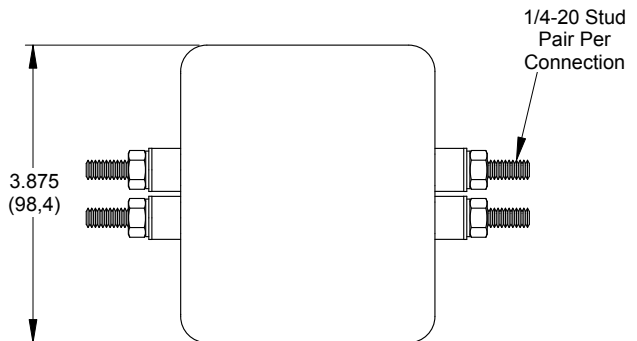
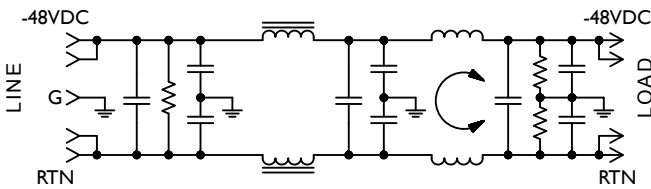

General Purpose

DC FILTERS



FD1 Filters

FD10EE050 (50Amp) Dimensions

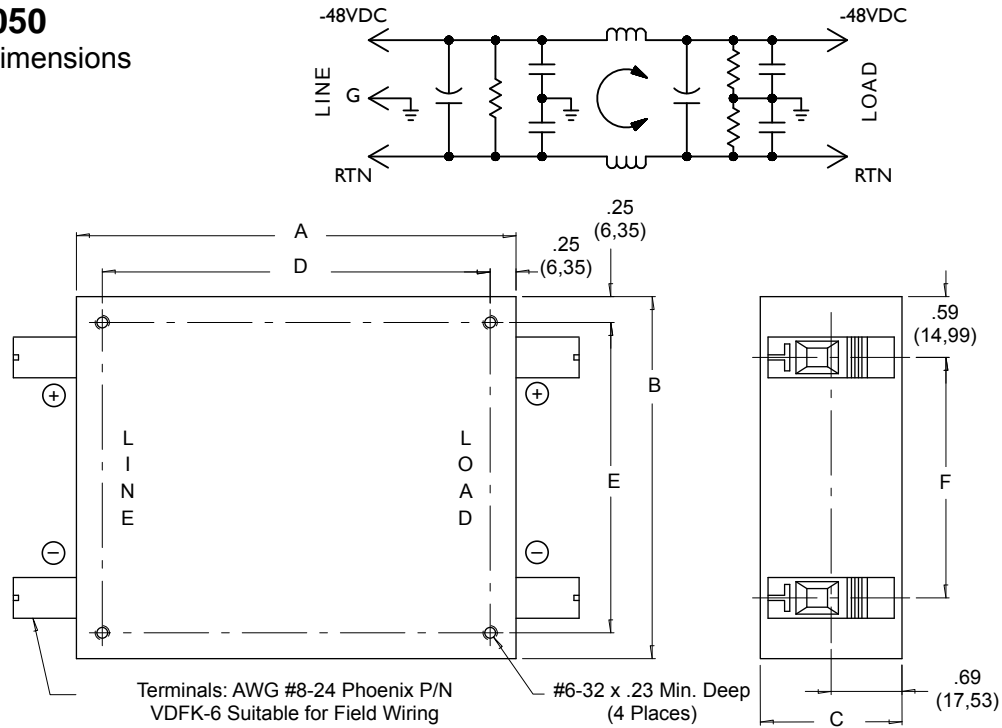

Amps	A	B	C	D	E	F
50A	4.25 (107,95)	3.50 (88,9)	1.37 (34,79)	3.750 (95,25)	3.000 (76,2)	2.33 (59,18)
100A	4.25 (107,95)	3.50 (88,9)	1.37 (34,79)	3.750 (95,25)	3.000 (76,2)	2.33 (59,18)

FD10BB100 (100Amp) Dimensions

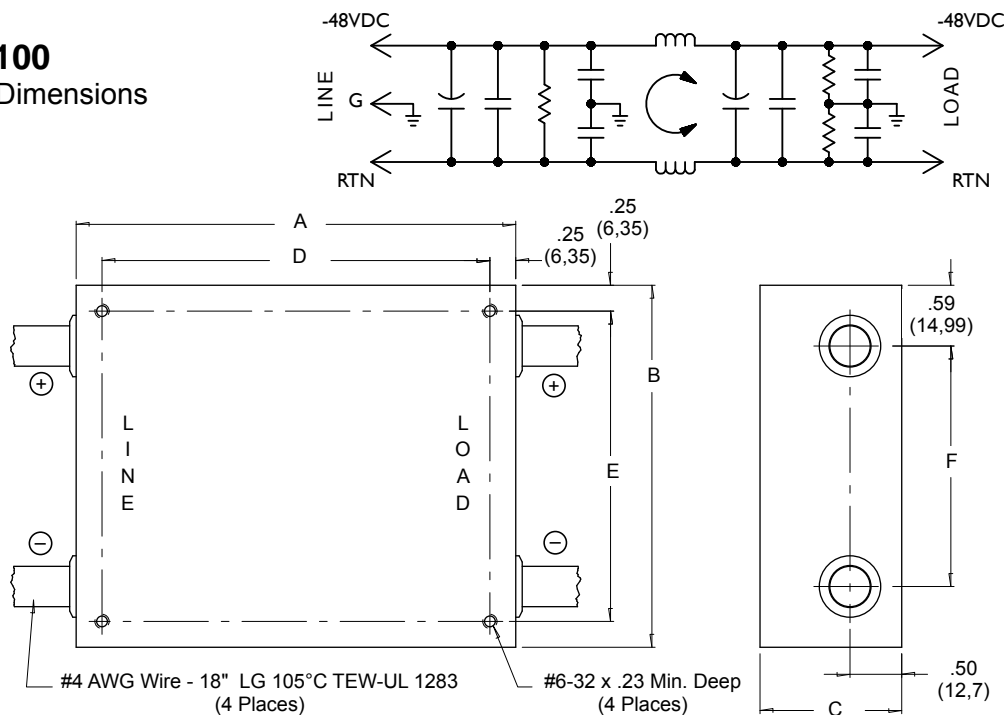

High Performance

DC FILTERS

Dimensions are in inches and millimeters unless otherwise specified. Values in parentheses are metric equivalents.



Curtis Industries
A Division of Powers Holdings, Inc.

1-800-657-0853

69

FD2 & FD3 Filters

FD20HC080

(30, 50 and 80Amp) Dimensions

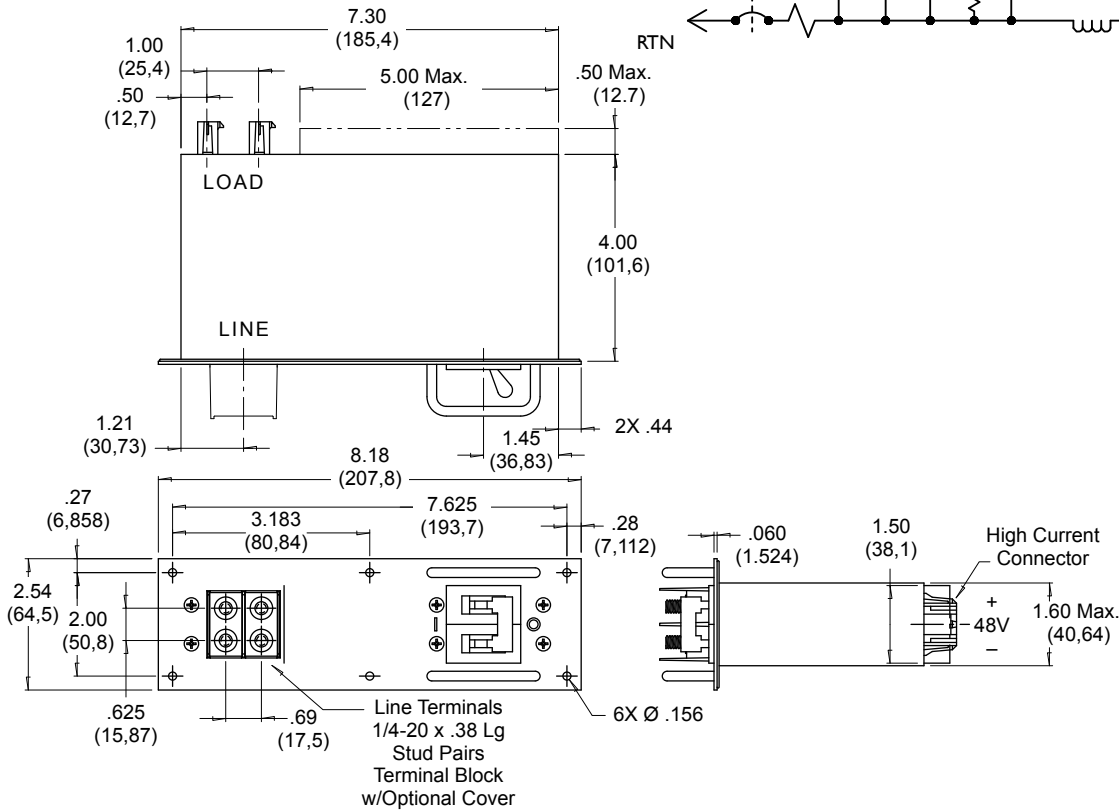

FD30RB100

(30, 50, 75 and 100Amp) Dimensions

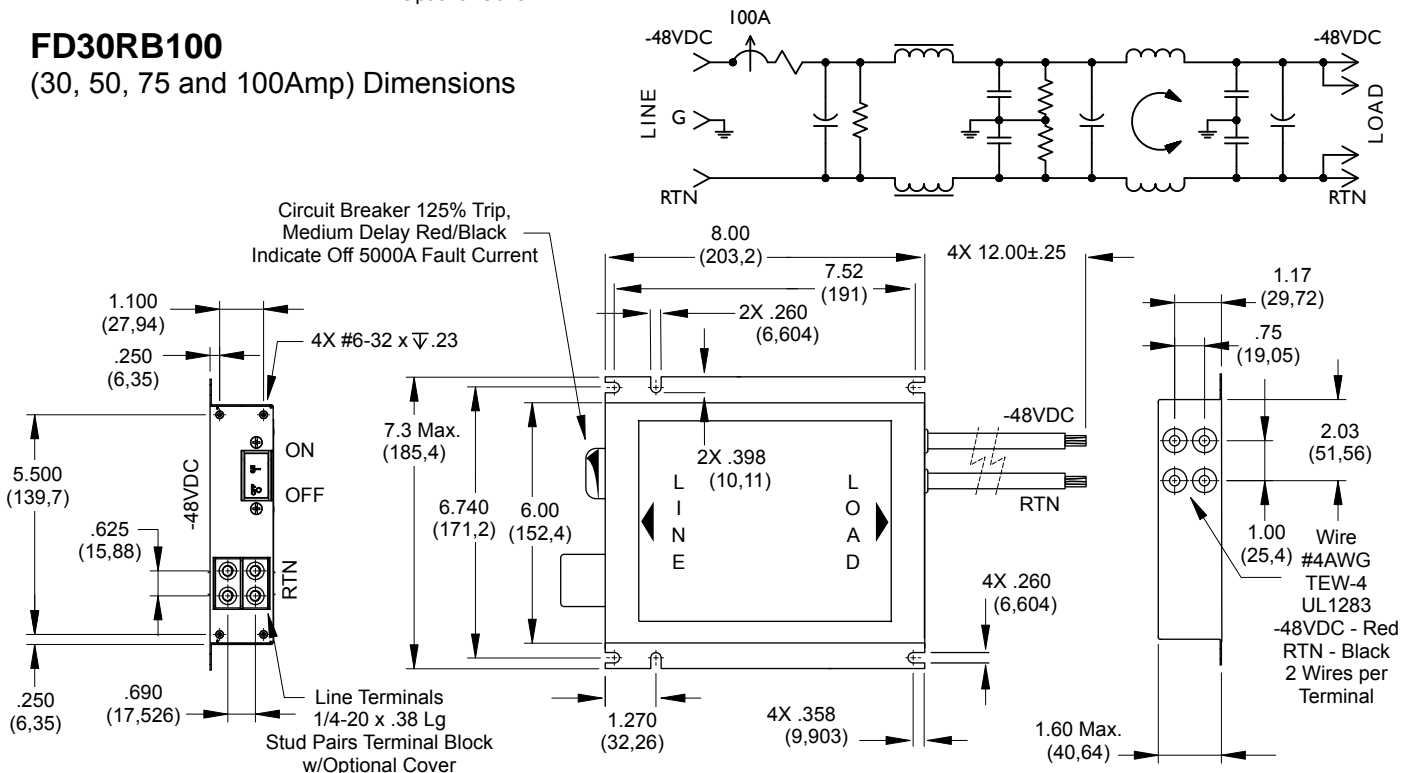

High Performance

DC FILTERS



MEDICAL FILTERS]

General Purpose Combination

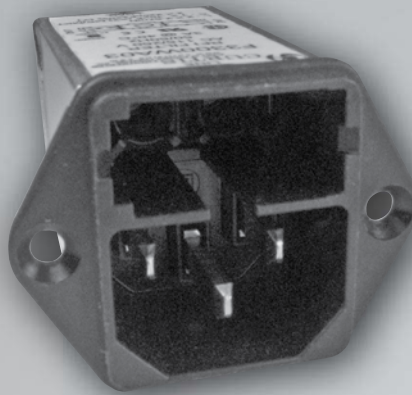
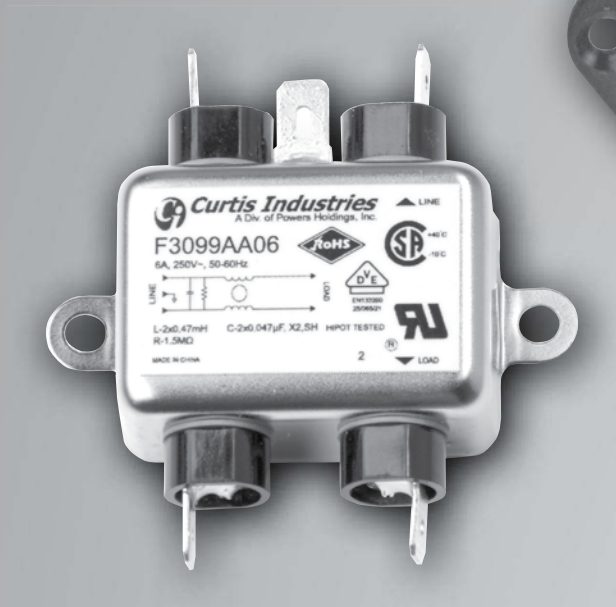

F3099 RFI Filters



Specifications:

Maximum Voltage: 250VAC Maximum - 50/60 Hz

Rated Current: 250VAC
6A

Current Overload: 6X for 8 seconds

Hi-Pot Test (1 min):

Line to Ground 1500VAC

Line to Line 1450VDC

Insulation Resistance: $9 \times 10^9 \Omega$ at 100VDC

Ambient Temperature: 40°C Max at rated current

Humidity Range: 0% to 95% R.H.

Termination:

A: Quick Connect

B: Wire

Maximum Leakage Current:

Each Line to Ground **F3000 Series**

115VAC, 60Hz: 2 μ A

250VAC, 50Hz: 5 μ A

Agency Approvals:



Features:

- Designed to Meet UL544 and IEC601 Specifications for Medical and Dental Equipment, both patient care and onpatient categories.
- Leakage current in this series is extremely low to satisfy the stringest leakage current limit imposed by safety regulations for medical and dental equipment.

F3099AA (6Amp) Dimensions

Amps	A	B	C	D	E
6A	2.53 (64,30)	1.82 (46,2)	0.78 (19,8)	2.126 (54,0)	2.53 (64,30)
	2.53 (64,30)	1.82 (46,2)	0.78 (19,8)	2.126 (54,0)	1.32 (33,5)

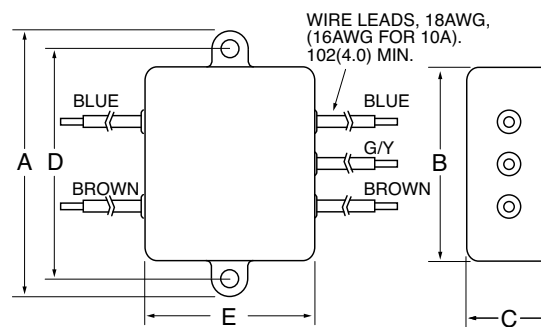
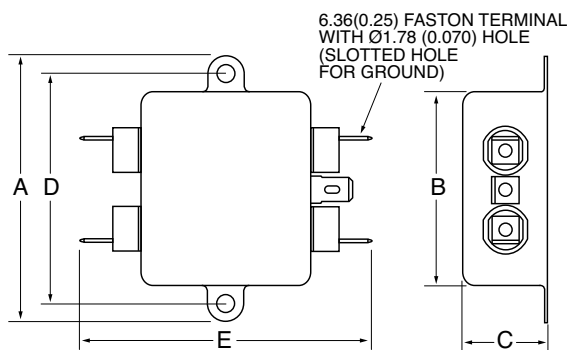

F3099 Series Simplified Schematic

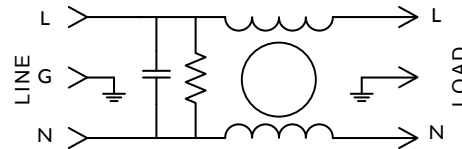

Nominal Current Rating	Part Number	Termination Line/Load	MINIMUM INSERTION LOSS - dB (50 ohm Circuit)								
			MODE	Frequency - MHz							
				0.05	0.10	.15	.50	1.0	5.0	10	30
6A	F3099AA06 F3099BB06	QC/QC Ø	Common	3	7	11	20	22	24	22	18
			Differential	3	6	14	20	30	35	35	35

NOTE: Other combinations of terminals may be specified on special order.

General Purpose Filtered Modules

MEDICAL FILTERS



F3000/3100/3200/3400/3500 RFI Filters

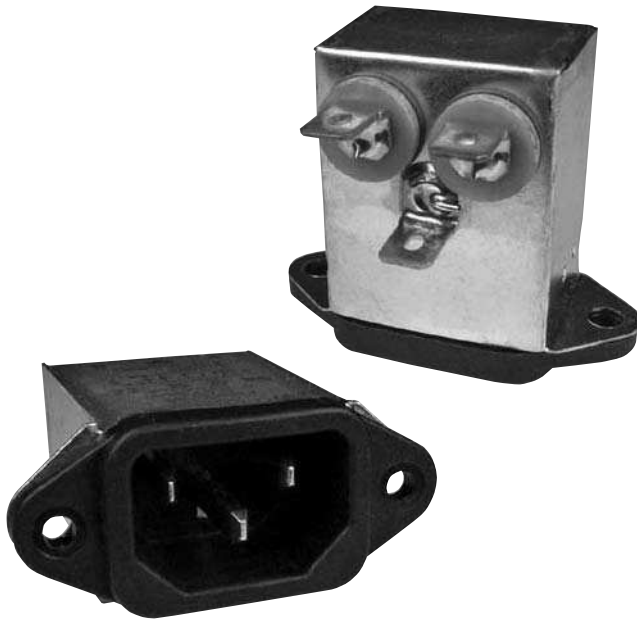

Specifications:

Rated Voltage: 250VAC Maximum - 50/60 Hz

Rated Current: 115VAC 250VAC
3A 3A
6A 6A

Current Overload: 6X for 8 seconds

Hi-Pot Test (1 min):

Line to Ground 1500VAC
Line to Line 1768VDC

Insulation Resistance: $9 \times 10^9 \Omega$ at 100VDC

Ambient Temperature: 40°C Max at rated current

Humidity Range: 0% to 95% R.H.

Termination:

A: QC – Quick Connect
C: IEC Receptacle

Maximum Leakage Current:

Each Line to Ground **F3000 Series**
115VAC, 60Hz: 2 μ A
250VAC, 50Hz: 5 μ A

Agency Approvals:



Features:

- Designed to Meet UL544 Specification for Medical and Dental Equipment. Available to UL/IEC 60601 Standard
- F3400/F3500 Have Enhanced Differential Mode Performance
- Effective in Other Low-Leakage Current Applications

**F3000/F3100/F3200 Series
Simplified Schematic**

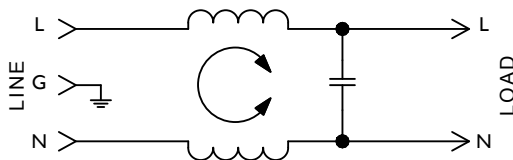

**F3400/F3500 Series
Simplified Schematic**

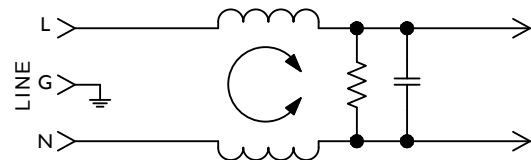

Nominal Current Rating	Part Number	Termination Line/Load	MINIMUM INSERTION LOSS - dB (50 ohm Circuit)						
			MODE	Frequency - MHz					
				.15	.50	1.0	5.0	10	30
3A	F3400CA03 F3500CA03	IEC/QC IEC/QC	Common	22	32	35	30	25	20
			Differential	8	18	24	35	35	35
6A	F3000AA06 F3100CA06 F3200CA06	QC/QC IEC/QC IEC/QC	Common	10	20	23	25	23	15
			Differential		2	8	32	34	23
			Common	15	21	24	24	22	26
	Differential	8	18	24	35	35	35		

NOTE: Other combinations of terminals may be specified on special order.

Dimensions are in inches and millimeters unless otherwise specified. Values in parentheses are metric equivalents.



Curtis Industries
A Division of Powers Holdings, Inc.

1-800-657-0853

General Purpose Filtered Modules

MEDICAL FILTERS

F3000/3100/3200/3400/3500 RFI Filters (continued)

General Purpose Filtered Modules

F3000AA
(6Amp)
Dimensions

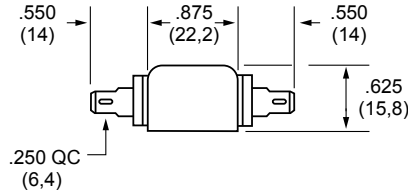
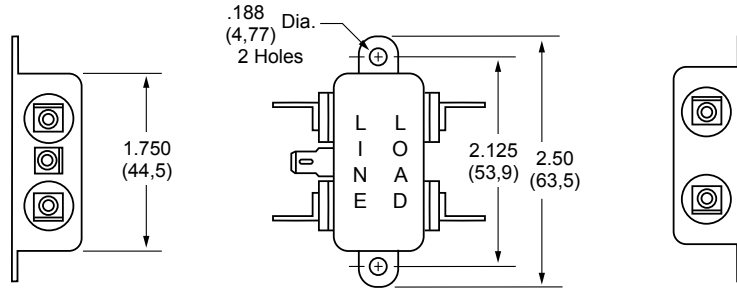

F3100CA
(6Amp)
F3400CA
(3 and 6Amp)
Dimensions

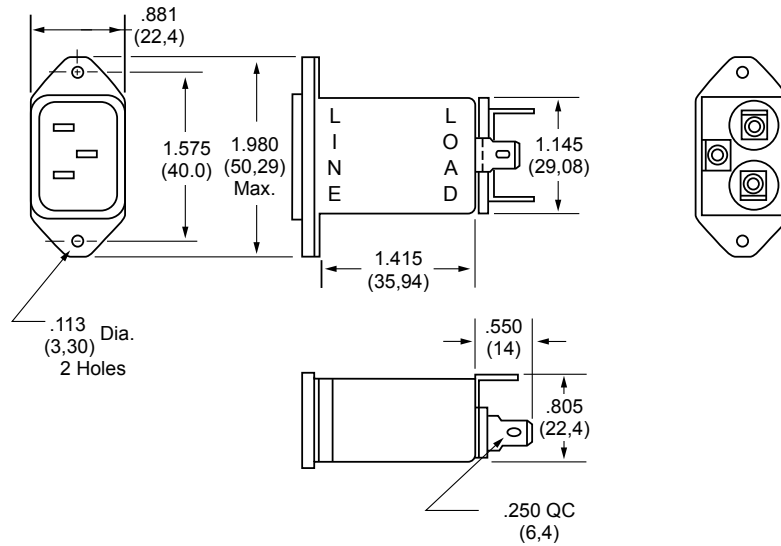

MEDICAL FILTERS

F3200CA
(6Amp)
F3500CA
(3 and 6Amp)
Dimensions

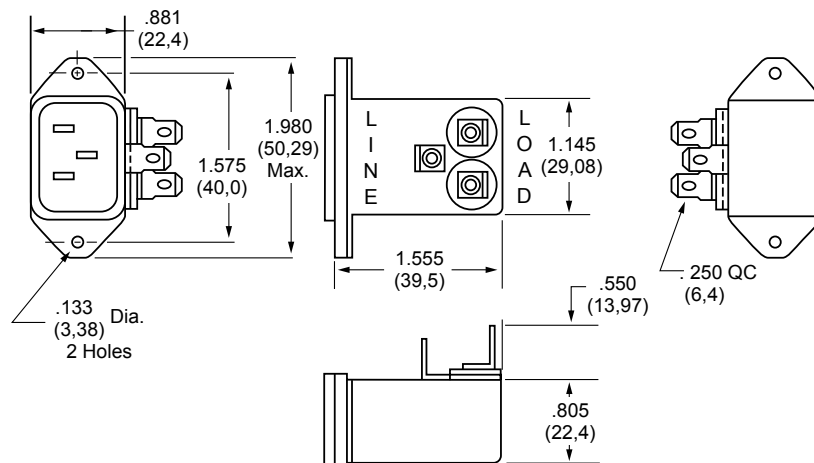

F3300 RFI Filters

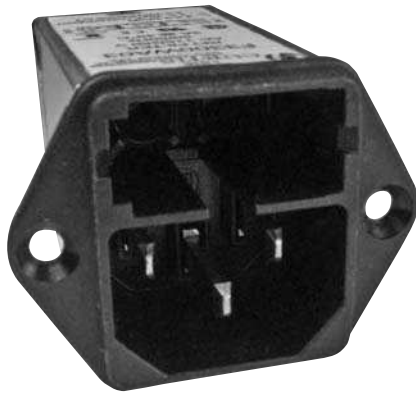

Features:

- General Purpose “L-Type” Circuit Effective in Reducing Both Incoming and Outgoing Powerline Noise Levels in FCC “A” Applications
- Integral 5 X 20mm Single or Dual Fused IEC Connector
- Optional SST Switched IEC Connector
- Low-Leakage
- Available to UL/IEC 60601 Standard and Meets UL 544 Specification for Medical and Dental Applications
- Available in Labor-Saving PC Mounted Case Style

Specifications:

Rated Voltage: 250VAC Maximum - 50/60 Hz

Rated Current: 115VAC 250VAC
 3A 3A
 6A 6A

Current Overload: 6X for 8 seconds

Hi-Pot Test (1 min):

Line to Ground 1500VAC
 Line to Line 1768VDC

Insulation Resistance: $9 \times 10^9 \Omega$ at 100VDC

Ambient Temperature: 40°C Max. at Rated Current

Humidity Range: 0% to 95% R.H.

Termination:

- A: QC – Quick Connect
- F: Fused IEC
- J: Switched IEC
- P: PC – P.C. Board
- W: Dual Fused IEC

Maximum Leakage Current:

Each Line to Ground **F3300**
 115VAC, 60Hz: .015mA
 250VAC, 50Hz: .025mA

Agency Approvals:



F3300F Simplified Schematic

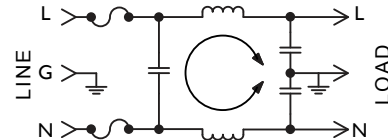

Nominal Current Rating	Part Number	Termination Line/Load	MINIMUM INSERTION LOSS - dB (50 ohm Circuit)						
			MODE	Frequency - MHz					
				.15	.50	1.0	5.0	10	30
3A	F3300FA03 F3300FP03	Fused IEC/QC Fused IEC/PC	Common	21	32	36	30	28	28
			Differential	8	18	24	35	35	35
6A	F3300FA06 F3300FP06	Fused IEC/QC Fused IEC/PC	Common	18	30	34	26	25	25
			Differential	8	18	24	35	35	35
3A	F3300WA03 F3300WP03	Dual Fused IEC/QC Dual Fused IEC/PC	Common	21	32	36	30	28	28
			Differential	8	18	24	35	35	35
6A	F3300WA06 F3300WP06	Dual Fused IEC/QC Dual Fused IEC/PC	Common	18	30	34	26	25	25
			Differential	8	18	24	35	35	35
3A	F3300JA03 F3300JP03	Switched IEC/QC Switched IEC/PC	Common	21	32	36	30	28	28
			Differential	8	18	24	35	35	35
6A	F3300JA06 F3300JP06	Switched IEC/QC Switched IEC/PC	Common	18	30	34	26	25	25
			Differential	8	18	24	35	35	35

NOTE: Other combinations of terminals may be specified on special order.

Dimensions are in inches and millimeters unless otherwise specified. Values in parentheses are metric equivalents.



Curtis Industries
 A Division of Powers Holdings, Inc.

1-800-657-0853

General Purpose Filtered Modules

MEDICAL FILTERS

F3300 Series *(continued)*

F3300FA (3 and 6Amp) Dimensions

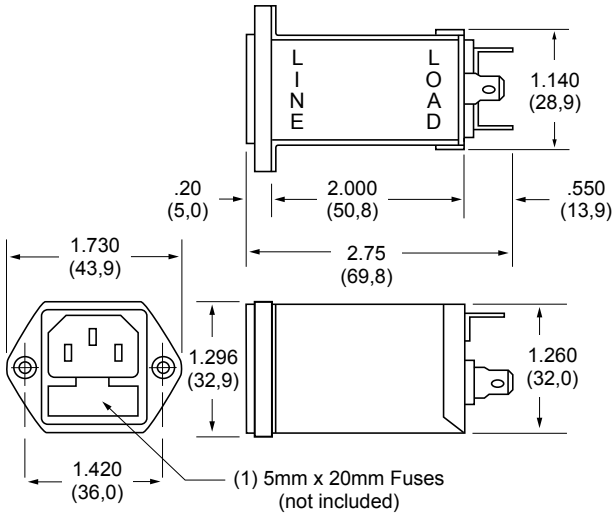

F3300FP (3 and 6Amp) Dimensions

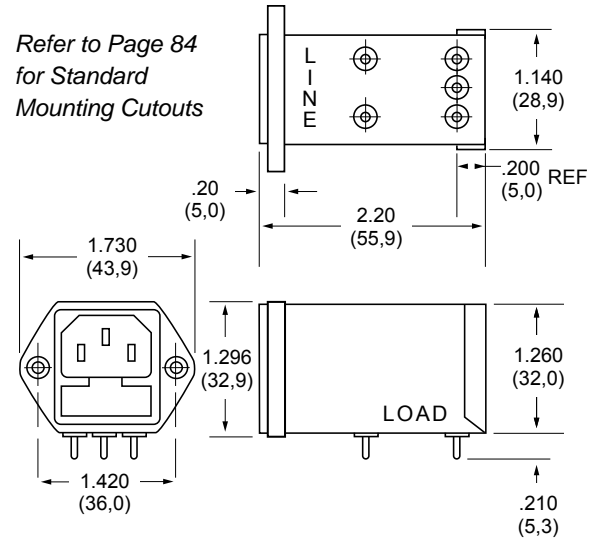

F3300WA (3 and 6Amp) Dimensions

F3300W Simplified Schematic

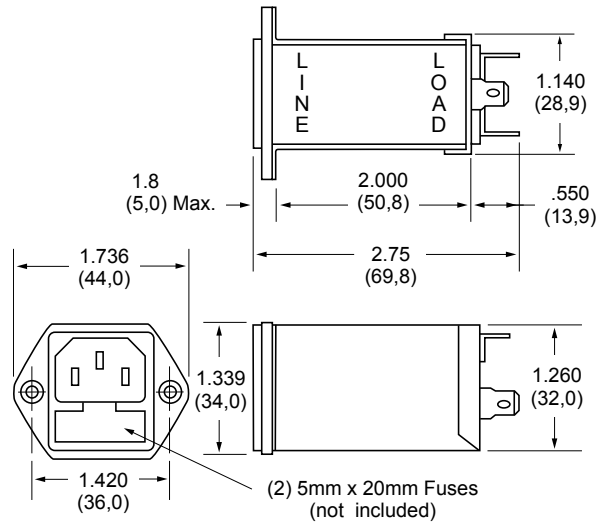
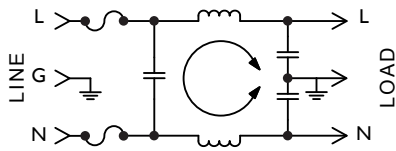

F3300JA (3 and 6Amp) Dimensions

F3300J Simplified Schematic

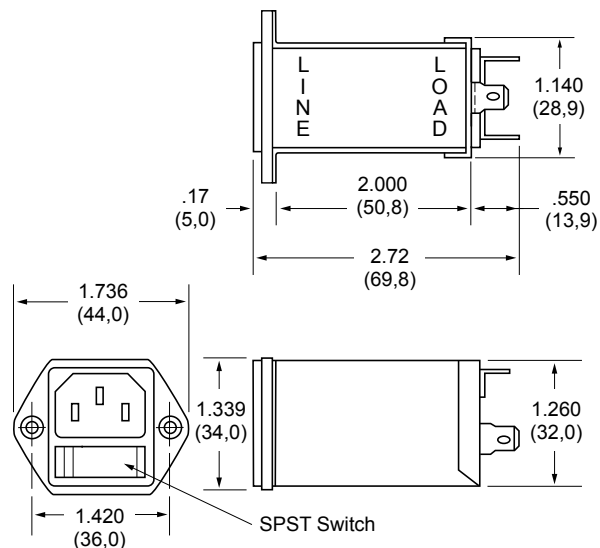
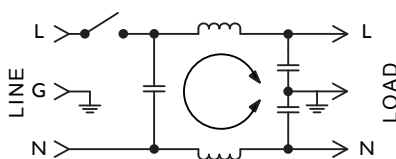

PM7/PM8 Series



Specifications:

Rated Voltage: 250VAC Maximum - 50/60 Hz

Rated Current: 115VAC 250VAC
3A 3A
6A 6A

Current Overload: 6X for 8 Seconds

Hi-Pot Test (1 min):

Line to Ground 1500VAC
Line to Line 1768VDC

Insulation Resistance: $9 \times 10^9 \Omega$ at 100VDC

Ambient Temperature: 40°C Max. at Rated Current

Humidity Range: 0% to 95% R.H.

Termination:

- IEC Receptacle
- Wire Wrap/Solder

Maximum Leakage Current:

Each Line to Ground **PM7, PM 8**
115VAC, 60Hz: 0.002mA
250VAC, 50Hz: 0.005mA

Voltage Select Card: Installed in 120VAC position unless otherwise specified

Agency Approvals:



Refer to Page 80 for Ordering Instructions

Features:

- RFI Filter Module Combines IEC Connector, Fusing, and Voltage Select Features in One Unit
- PM7 Series Filters Provide 20% More Differential Mode Attenuation Than Comparable Units
- Accepts Either U.S. or European Standard Fuse Sizes
- Available to UL/IEC 60601 Standard and Meets UL 544 Specification for Medical and Dental Applications

PM7 Series Simplified Schematic

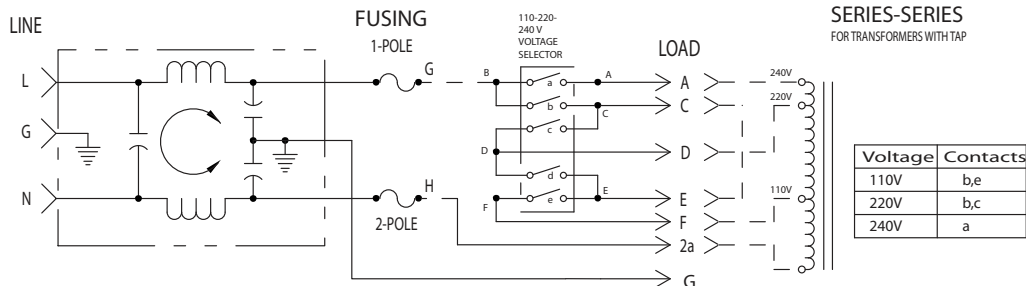

Nominal Current Rating	Part Number	Termination Line/Load	MINIMUM INSERTION LOSS - dB (50 ohm Circuit)						
			MODE	Frequency - MHz					
				.15	.50	1.0	5.0	10	30
3A	PM7XXX03 PM8XXX03	IEC/Solder Tabs	Common	14	20	22	24	22	15
			Differential	8	18	24	46	50	40
6A	PM7XXX06 PM8XXX06	IEC/Solder Tabs	Common	10	15	18	18	18	15
			Differential	8	18	24	39	40	40

NOTE: Other combinations of terminals may be specified on special order.

Dimensions are in inches and millimeters unless otherwise specified. Values in parentheses are metric equivalents.



Curtis Industries
A Division of Powers Holdings, Inc.

1-800-657-0853

Combination

MEDICAL FILTERS

PM7/PM8 Series (continued)

PM7 Series Simplified Schematic

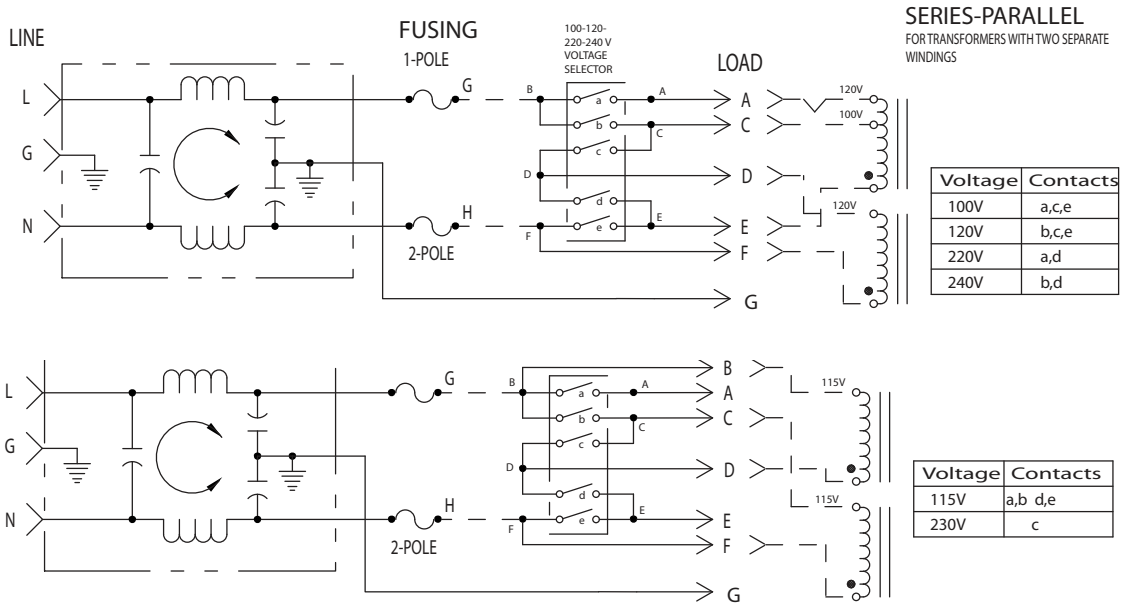

PM8 Series Simplified Schematic

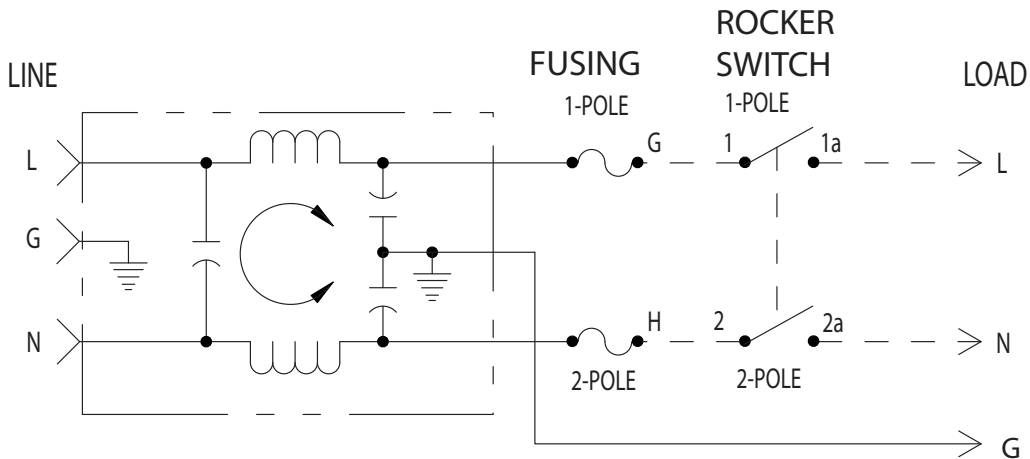

Combination

MEDICAL FILTERS



PM7/PM8 Snap-Mount Series (3 and 6Amp) Dimensions

Refer to Page 80
for Standard
Mounting Cutouts

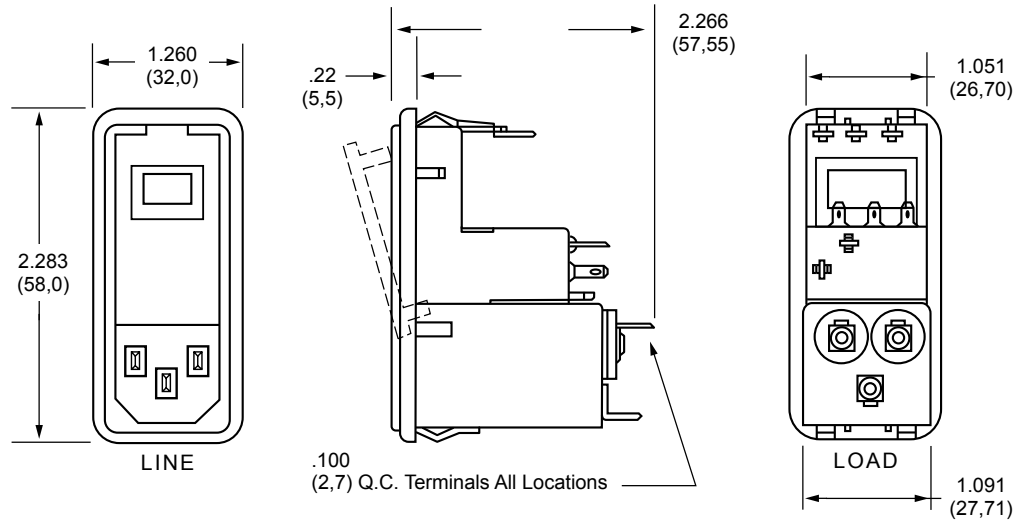

PM7/PM8 Screw-Mount Series (3 and 6Amp) Dimensions

Refer to Page 80
for Standard
Mounting Cutouts

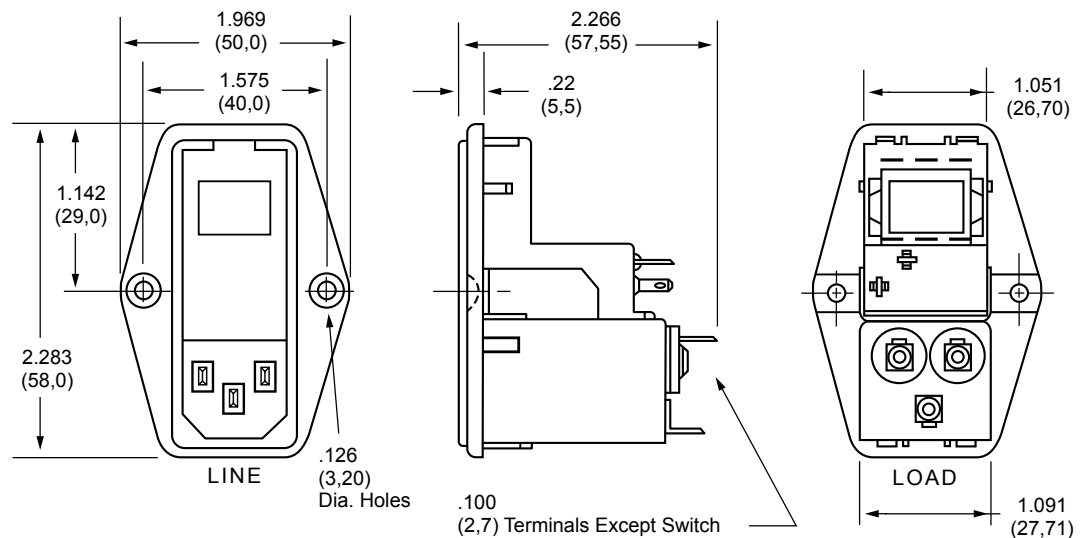

PM7/PM8 Series *(continued)*

How to Order

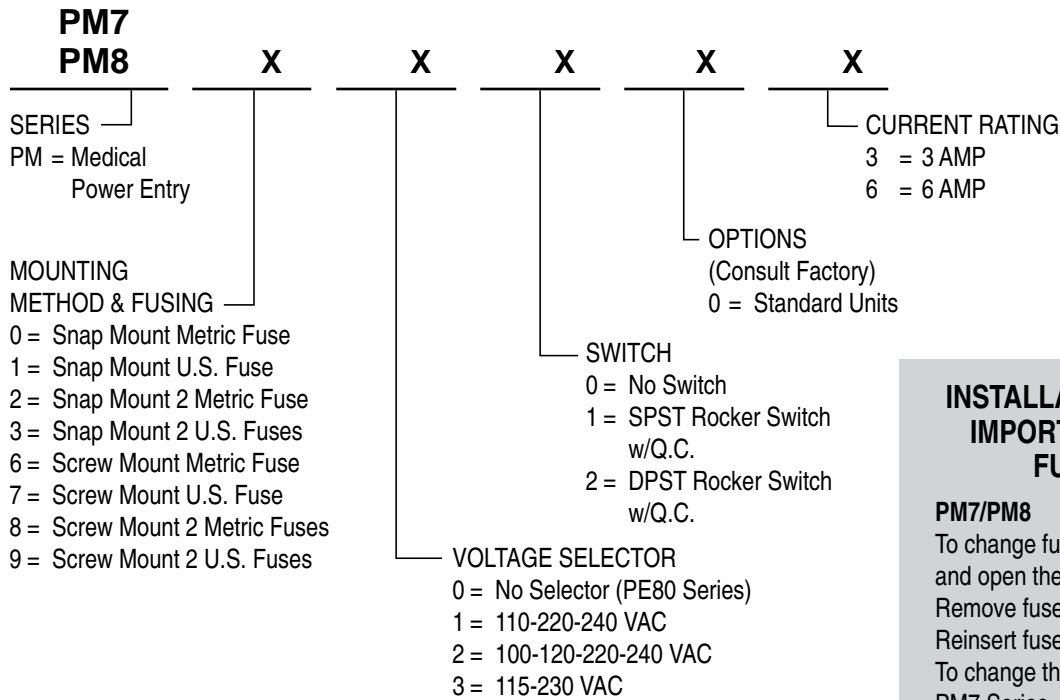

INSTALLATION INSTRUCTION IMPORTANT – CHANGING FUSE/VOLTAGE

PM7/PM8

To change fuse, remove power cord and open the front cover on the module. Remove fuse holder and replace fuse. Reinsert fuse holder and close cover. To change the operating voltage on the PM7 Series, remove the power cord and open front cover. Rotate voltage select wheel until desired voltage appears in window of cover.

- Filter shipped without fuse.

Always use caution when selecting and changing fuses and voltage requirements. Curtis Industries is not responsible for malfunction due to improper installation/selection of fuse and/or voltage select.

Combination

MEDICAL FILTERS

PM7/PM8 Snap-Mount Series

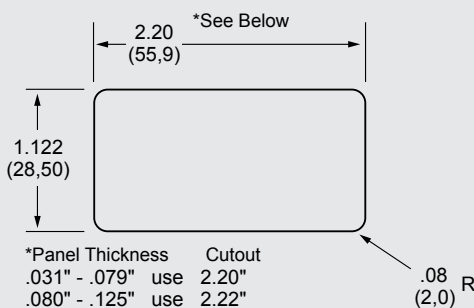

PM7/PM8 Screw Mount Series

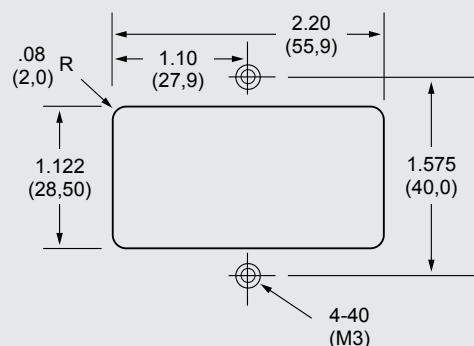



Features:

- RFI Filter Module Combines IEC Connector, Fusing, Optional Voltage Select and On/Off Switch into a Single, Space-Efficient Assembly
- Enhanced Low Frequency Response with No Resonant Peaks
- Fully Shielded for Radiative Noise Control
- Accepts Either U.S. or European Standard Fuse Sizes. Dual or Single Power Line Fusing
- Meets IEC 60601 Standard and Meets UL 544 Specification for Medical and Dental Applications

Specifications:

Rated Voltage: 250VAC Maximum - 50/60 Hz

Rated Current: 115VAC 250VAC
10A 10A

Current Overload: 6X for 8 seconds

Hi-Pot Test (1 min):

Line to Ground 1500VAC
Line to Line 2250VDC

Insulation Resistance: $9 \times 10^9 \Omega$ at 100VDC

Ambient Temperature: 40°C Max at rated current

Humidity Range: 0% to 95% R.H.

Termination:

- QC – Quick Connect
- IEC Receptacle

Maximum Leakage Current:

Each Line to Ground	PM1	PM1-PO
115VAC, 60Hz:	0.002mA	0.015mA
250VAC, 50Hz:	0.005mA	0.025mA

Voltage Select Card: Installed in 120VAC position unless otherwise specified

Agency Approvals:



PM1 Series Simplified Schematic without Voltage Selector

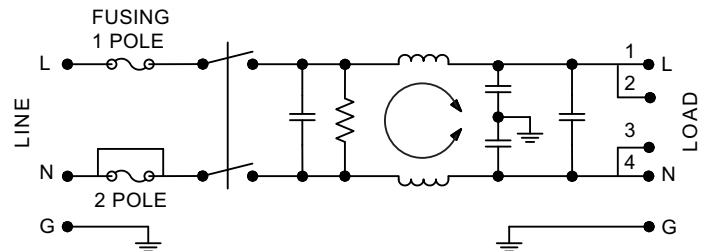

PM1 Series Simplified Schematic with Voltage Selector

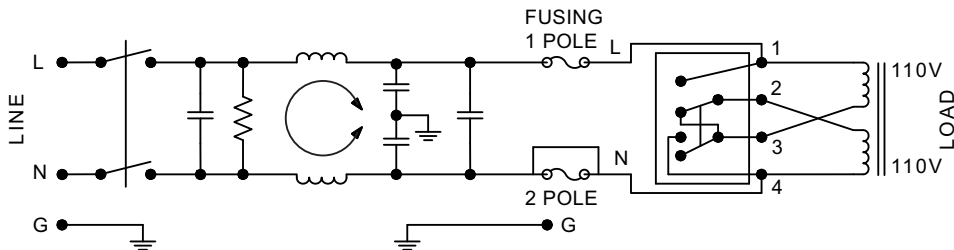

Nominal Current Rating	Part Number	Termination Line/Load	MINIMUM INSERTION LOSS - dB (50 ohm Circuit)								
			MODE	Frequency - MHz						10	30
				.05	.15	.50	.10	5.0	10		
10A	PM1XXX10	IEC/QC	Common Differential	10 10	20 20	30 30	33 35	25 55	20 60	15 55	
	PM1XXXP0	IEC/QC	Common Differential	123 10	234 20	30 30	35 35	25 65	25 65	30 55	

NOTE: Other combinations of terminals may be specified on special order.



PM1
(10Amp)
Dimensions

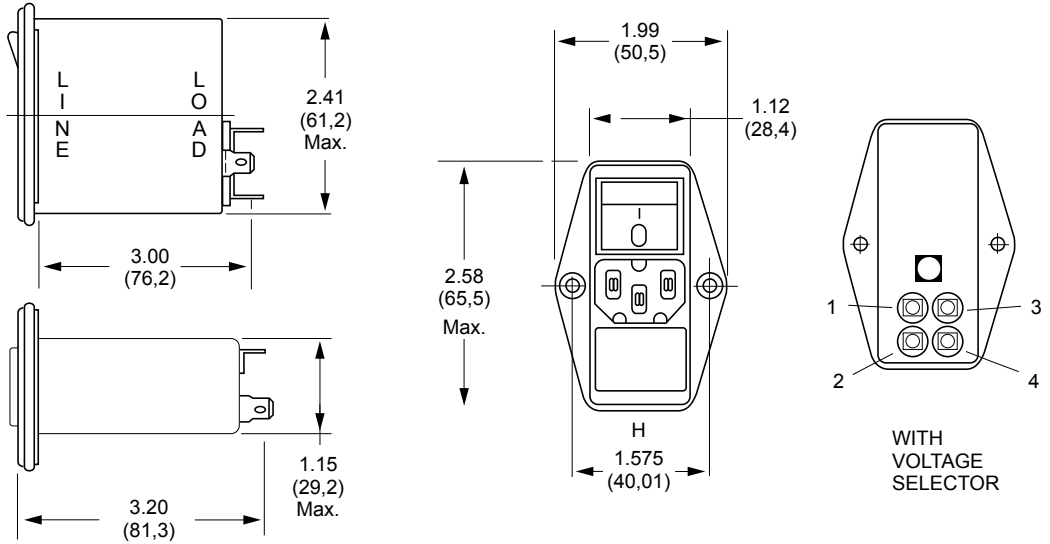

How to Order

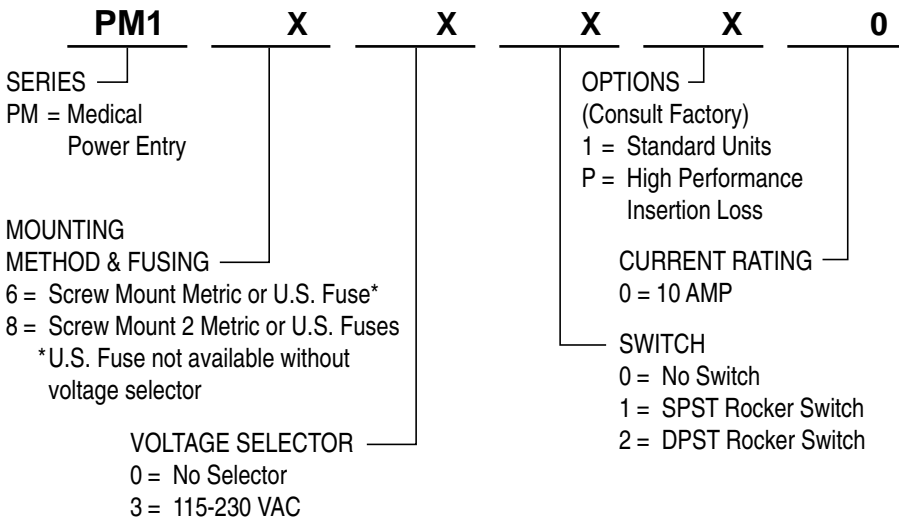

INSTALLATION INSTRUCTION
IMPORTANT – CHANGING FUSE/VOLTAGE

PM1
To change fuse, remove power cord. Remove voltage selector and replace fuse. Reinsert fuse holder. To change the operating voltage on the PM1 Series, remove the power cord and rotate fuse holder block until desired voltage aligns with the mark on the module housing.

- **Filter shipped without fuse.**

Always use caution when selecting and changing fuses and voltage requirements. Curtis Industries is not responsible for malfunction due to improper installation/selection of fuse and/or voltage select.

Combination

MEDICAL FILTERS

PM1 Screw Mount Series

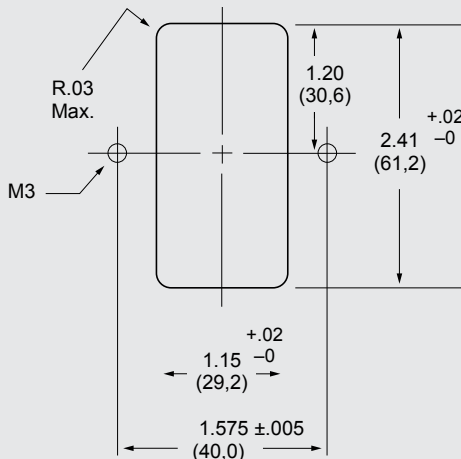

TECHNICAL CONSIDERATIONS]

Understanding Terminology

Technical Considerations

Conducted Emissions Testing

Custom Filter Capabilities



Understanding Terminology

Curtis Industries, a leading manufacturer of superior-quality electronic and electrical components and assemblies for more than 70 years, offers a complete line of RFI power line filters designed to help your equipment meet FCC and CE requirements on conducted EMI.

Radio frequency interference (RFI) is unwanted noise generated by a wide variety of electronic and electrical devices. Governments of most industrial

countries, including the United States, Canada and the European Union have enacted guidelines on emitted RFI.

Curtis designs quality into every product and then tests for quality by specification compliance, including hipot, component value, grounding and leakage, on a 100% production basis. We employ a rigorous component qualification program with thorough incoming and on-line inspection procedures. Our computer-controlled 100% safety and performance testing to demanding customer requirements is your assurance of the highest quality RFI filters available today.

This section provides you with some basic knowledge on terminology and technical information helpful in solving your noise emission in power circuits. For additional information visit our website at www.curtisind.com.



TECHNICAL
CONSIDERATIONS

Definitions

Attenuation: The decrease in intensity or absorption of electromagnetic energy. Expressed in dB.

Conducted Interference: Electromagnetic signals entering a device through direct connection.

Emissions: The level of electromagnetic disturbances equipment causes to its environment.

Filter: Remove electrical noise or interference from the power line by cleaning up the sine wave.

Immunity: The level to which equipment is immune to electromagnetic disturbances in its environment

Impedance: Opposition to the flow of electrical current when a given voltage is applied.

Inductor: Passive component that produces a voltage proportional to the change in current. Measured in Henrys.

Insertion Loss: The electromagnetic signal loss resulting from the insertion of a filter in a transmission line. Expressed in dB.



What is RFI?

Radio frequency interference (RFI) is the radiation or conduction of radio frequency energy (or electronic noise) produced by electrical and electronic devices at levels that interfere with the operation of adjacent equipment. Frequency ranges of most concern are 10 kHz to 30 MHz (conducted) and 30 MHz to 1 GHz (radiated).

What causes RFI?

The most common sources include components such as switching power supplies, relays, motors and triacs. These devices are found in a wide variety of equipment used in industrial, medical, white goods, and building HVAC equipment.

What are the types of RFI?

An electrical or electronic device emits RFI in two ways:

- **Radiated RFI** is emitted directly into the environment from the equipment itself.
- **Conducted RFI** is released from components and equipment through the power line cord into the AC power line network. This conducted RFI can affect the performance of other devices on the same network.

How can RFI be controlled?

- **Radiated RFI** is usually controlled by providing proper shielding in the enclosure of the equipment.
- **Conducted RFI** can be attenuated to satisfactory levels by including a power line filter in the system.

The filter suppresses conducted noise leaving the unit, reducing RFI to acceptable levels. It also helps to lower the susceptibility of the equipment to incoming power line noise that can affect its performance.

What is the government's role in regulating RFI?

Governments and safety agencies of major industrial countries, including the United States, Canada, and the European Union have established noise emission regulations that are focused on digital and other electronic equipment. The most important of these guidelines are FCC CFR 47 (Parts 15 and 18) in the United States and CISPR 11, 14 and 22 in the European Union.

FCC CFR 47 (Part 15) regulates the RF

interference of electronic computing devices, defined as any electronic device or system that generates and uses timing signals or pulses at a rate in excess of 10,000 pulses (cycles) per second and uses digital techniques. This definition includes telephone equipment that utilizes digital techniques and any device or system that generates and uses radio frequency energy for the purpose of performing data-processing functions such as electronic computations, operations, transformations, recording, filing, sorting, storage, retrieval or transfer.

FCC regulations are broken down into **Class A** computing devices marketed for use in commercial, industrial or business environments, and **Class B** devices intended for use in a residential environment.

The European Union has harmonized the various national regulations and has established the international standards CISPR 11, 14 and 22. CISPR 11 covers industrial, scientific and medical equipment. CISPR 14 covers electrical and thermal appliances and tools. CISPR 22 covers information technology equipment.

In addition to governmental regulations, safety agencies worldwide have established guidelines for all electrical/electronic components. These include UL, CSA and TUV. They are designed to protect against shock and fire hazard.

How do RFI power line filters work?

Consisting of a multiple-port network of passive components arranged as a dual low-pass filter, the RFI filter attenuates radio frequency energy to acceptable levels, while permitting the power frequency current to pass through with little or no attenuation. Their function, essentially, is to trap noise and to prevent it from entering or leaving your equipment.

RFI is conducted through a power line in two modes. Asymmetric or **common mode** noise occurs between the line and ground. Symmetric or **differential mode** is measured from line to line. See the selection guide on page 2 under "Performance."



Technical Considerations

Meeting Emissions Standards

The emissions limits that a piece of equipment must meet will depend on the intended market for that piece of equipment. If there is more than one market, more than one emission standard may have to be met. This can have a substantial effect on the circuit, size, and cost of a filter. Standards like the CISPR's or the FCC Rules Part 15 have frequency limits of 150 kHz to 30 MHz.

FCC 15 AND CISPR CONDUCTED EMISSION LIMITS DIGITAL EQUIPMENT

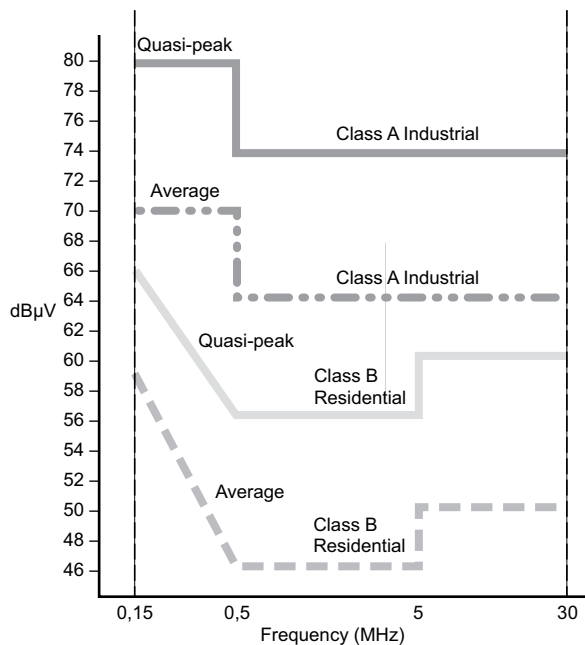

EMI measurements are generally made using Spectrum Analyzers with Average or Quasi-Peak detectors in accordance with methods described in CISPR 16. Quasi-Peak differs from Average measurements by weight-averaging the peaks into the total.

Equipment meeting these specifications can utilize a filter with a fairly high cutoff frequency. Other standards like FCC 18 with a low frequency limit of 10 kHz will result in the equipment using lower cutoff filters. As might be expected, the lower the cutoff frequency, the larger the physical size and the higher the cost of the filter.

Conducted RFI Susceptibility

The problem of susceptibility can be extremely difficult to deal with because the amplitude and frequency of the offending RF noise are seldom known and are often intermittent. If the malfunction can be duplicated by isolating the equipment from the power line with LISN's

(Line Impedance Stabilization Network) and using signal generators to inject RF of varying amplitude and frequency, some insight can be gained as to the nature of the problem. However, the criteria for acceptable performance will have to be decided upon so that a filter yielding this level of performance can be obtained from the test procedure. Unfortunately, this still does not eliminate the need for final testing in the actual operating environment which, in many cases, occurs in the field.

Selection of a suitable filter can best be based on the type of power supply or input impedance of the equipment and on the mode of the offending RFI noise.

Noise Modes

Power line filters attenuate noise in two different modes.

Common Mode: Also known as line-to-ground noise measured between the power line and ground potential.

Differential Mode: Also known as line-to-line noise measured between the lines of power.

Power line filters are designed to attenuate either one or both modes of noise. The need for one design over another will depend on the magnitude of each noise type present. The attenuation is measured in dB (decibels) at various frequencies of signal.

Circuit Configuration

Power line RFI filters are generally built with two or three-pole filter networks. As the number of poles and the corresponding component count increases, the cost will increase also. Trying to typify an equipment's impedance as either high or low for purposes of filter selection may not be successful. If it is a complex impedance, it could probably be low at some frequencies, high at others, and some intermediate value at still other frequencies.

Although we have been generally successful in recommending a two-pole network for linear power supplies and three-pole networks for switching power supplies and synchronous motors, you should not limit your testing to just one circuit type if either additional circuit performance or lower cost is desired. Consider the following: If the equipment looked strictly capacitive, the performance of a two-pole network would be reduced to that of a single-pole filter.

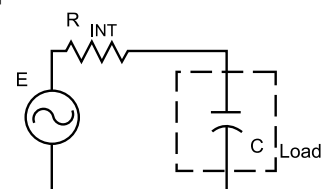

Figure 1a.
A signal source (E) with its internal impedance driving a capacitive load.



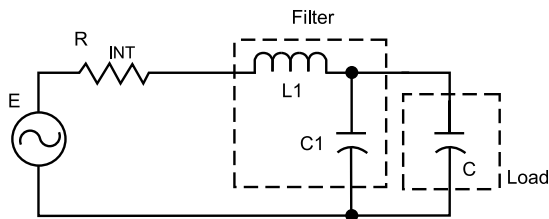
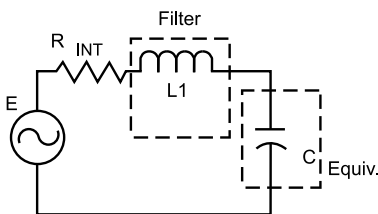

Figure 1b.

The same circuit as in Figure 1a, with the addition of a 2-pole low pass filter. Notice filter capacitor C1 is in parallel with the capacitive load.

Figure 1c.

Combining capacitor C1 in Figure 1b, with the load results in this circuit configuration.



The filter has been reduced to one inductive element, L1.

Obviously a three-pole filter would be preferred for maximum performance. Likewise, if the equipment looked strictly inductive, the performance of a three-pole network would be reduced to that of a two-pole network.

Figure 2a.

A signal source with its internal impedance driving an inductive load.

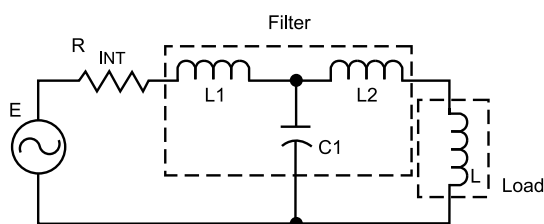
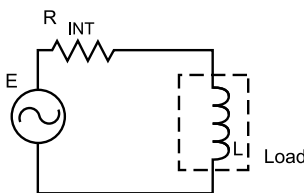

Figure 2b.

The same circuit as in Figure 2a, with the addition of a 3-pole low pass filter. Notice filter inductance L2 is in series with the inductive load.

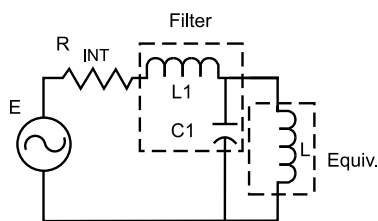

Figure 2c.

Combining inductor L2 in Figure 2b, with the load results in this circuit configuration, the filter has been reduced to two effective elements, L1 & C1.

Undoubtedly the two-pole filter would be a more economical choice with probably equal performance in this application. Since the equipment is not likely to be equivalent to either one of these simple cases, the only way to find the best cost-effective solution is to test the filters in your equipment and base your judgement on these test results.

Leakage Current

The maximum leakage current that a device is allowed depends on the requirements of the particular safety agency involved. Here, selection of the filter is quite easy since either the filter is designed to meet a given level or it is not. Although there is no compromise when it comes to safety specifications, it should be understood that for a given level of performance, as the leakage current is reduced, the physical size of the package will increase. Curtis medical filters have a very low leakage current.

Insertion Loss

DO NOT use the insertion loss specifications to make your final decision. Power line filters are two-terminal pair passive networks whose attenuation characteristics can be defined by a complex transfer function. How that transfer function will react in a particular system and at specific frequencies will depend on the complex impedances connected to each side of the filter. The equipment impedance and the impedance of the power line, even if a 50 ohm LISN (Line Impedance Stabilization Network) is being used during emission testing, will not generally be equal to the resistive 50 ohms used during insertion loss measurements. Therefore, the performance of the filter in the equipment cannot be related to the published insertion loss data.

Minimum Insertion Loss

Do not be alarmed that the insertion loss figures we have published may be of lower value than those of our competition. You will only find guaranteed minimum insertion loss figures in this catalog, without any mention of typical values.

Insertion loss test data measured in a 50 ohm system is a valuable incoming inspection tool to assure you that consistent product is being shipped. The only figures of any importance are those that specify the criteria for acceptance or rejection of that product, and those figures are the minimum values.



RFI/EMI Conducted Emissions Testing

Curtis offers full RFI/EMI conducted emissions testing services for manufacturers who must produce equipment in accordance with FCC and CE standards.

Curtis testing facilities consist of a laboratory equipped to test and evaluate EMI characteristics of equipment that must comply with FCC Part 15 and/or CISPR standards. With these facilities, Curtis can provide manufacturers with greater assistance in the selection of RFI/EMI filters to help them meet the necessary emission levels.

Isolated Environment Enhances Test Capabilities

- Totally isolated environment for both equipment under test and test instrumentation provided by separate chambers.
- RF screen room shielded against magnetic, electric and plane wave field per MIL-STD-285.
- Specially constructed line impedance stabilization networks (LISN) for FC Part 15 and CISPR testing.
- Sensitive, reliable automatic measurement and recording of conducted emissions data from 10 KHz to 1 GHz.
- Computer-controlled Agilent E7402A Spectrum Analyzer with associated amplifiers and attenuators.
- Agilent E7402A graphics capabilities allow quick generation of hard copies of emissions test results.

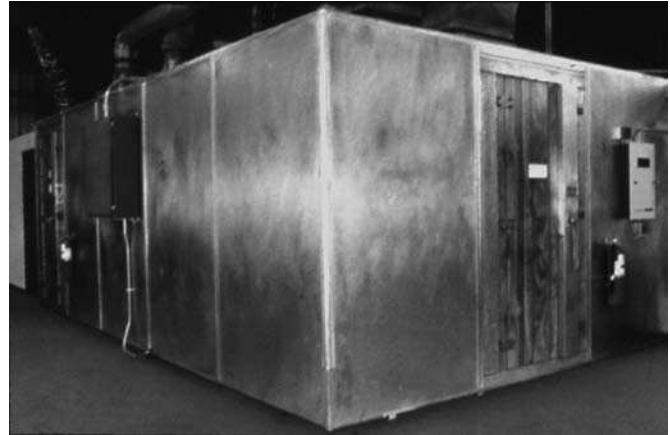

The Curtis screen room provides complete RFI isolation for equipment under test and the test instrumentation.

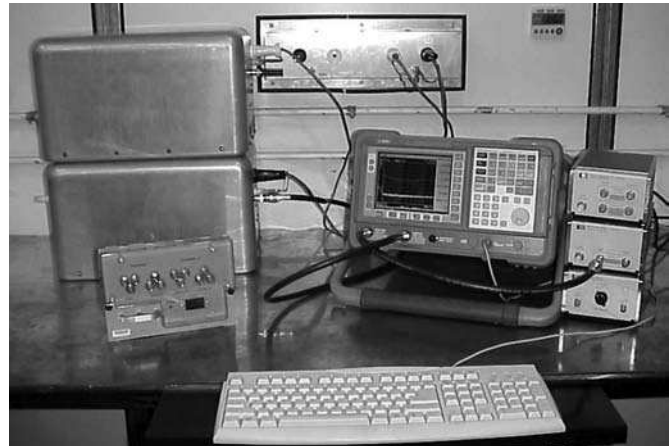

Computer-controlled test equipment assures fast turnaround on RFI emissions testing.

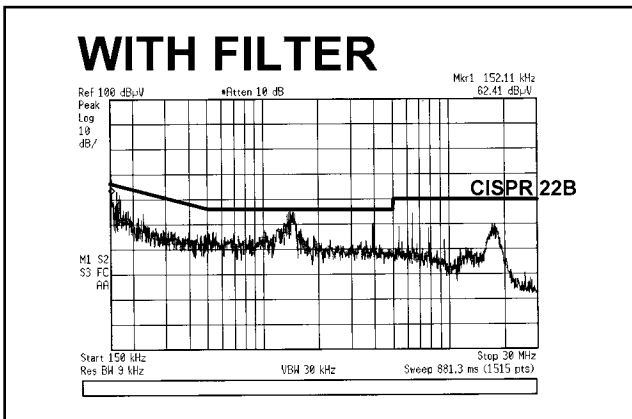

Fast Pre-Compliance Test Results

Computer-generated graphics and test reports provide the customer with fast turnaround on all testing.

On-site RFI filter design/applications engineers are available to assist in evaluating test results and to determine cost-effective solutions to conducted emissions problems before going to agencies.

Please contact your local Curtis representative or the factory sales staff to coordinate pre-compliance testing of your equipment at Curtis Industries.



Curtis can provide environmental testing to demonstrate performance and survival in harsh conditions.



Custom Filter Capabilities *We Build Confidence!*

Curtis has the capability to modify any of our standard filters or to work with you from design to delivery on a completely custom filter to meet your exact mechanical and electrical requirements. The Curtis Filter Engineering Team, drawing from our extensive knowledge and experience, is fully equipped and qualified to consult with you on your RFI and EMI emission control problems. Curtis has the ability to test your equipment in our technologically advanced screen room to help you select the proper filter for your application.



Information We Need From You

Specifications:

* Rated Voltage: _____ * Line Frequency: _____

* Rated Current: _____ * Max. Temperature: _____

Current Overload: _____ Humidity Range: _____

Max. Leakage Current (Each Line to Ground) _____

Dimensions: _____

Terminal Type: Input (Line): _____

Output (Load): _____

Mounting Torque (Panel-Mount Models Only): _____

Test Specifications:

Hipot Test: Line to Ground: _____ VAC for One min.

Line to Line: _____ VDC for One min.

Insulation Resistance: _____

* Minimum Insertion Loss (50Ω Circuit):

	Frequency (MHz)						
	.01	.15	.5	1	5	10	30
CM							
DM							

Organization Approvals: UL _____ CSA _____ TUV _____ Other _____

Company Name: _____ Contact: _____

E-mail Address: _____ Phone Number: _____

** Required*

Curtis Contact Information

E-mail: sales@curtisind.com

Fax: 414-649-4279

Phone Number: 1-800-657-0853

Address: P.O. Box 343925, Milwaukee, WI 53234-3925



Curtis Industries
A Division of Powers Holdings, Inc.



RFI Power Line Filters



Filtered Power Entry



Custom Filters



DIN Rail

Curtis Family of Products

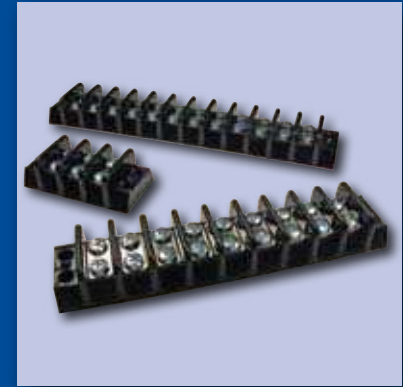

Terminal Blocks



PCB Mount Blocks

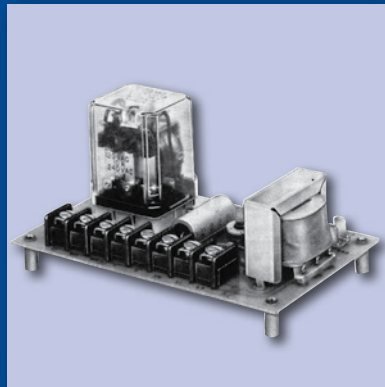

Liquid Level
Controllers



Custom Terminal Blocks



Curtis Industries

A Div. of Powers Holdings, Inc.

2400 S. 43rd St., Milwaukee, WI 53219

1-800-657-0853

www.curtisind.com