

REV.	E.C.N. NUMBER AND REVISION COMMENTS	DATE
A	E.C.N. #10BRDR. & REDRAWN.	1.5.99
B	E.C.N. #10702.	1.10.01

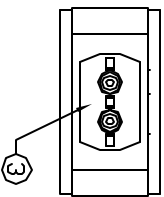
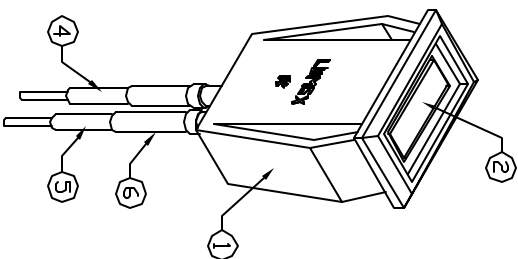
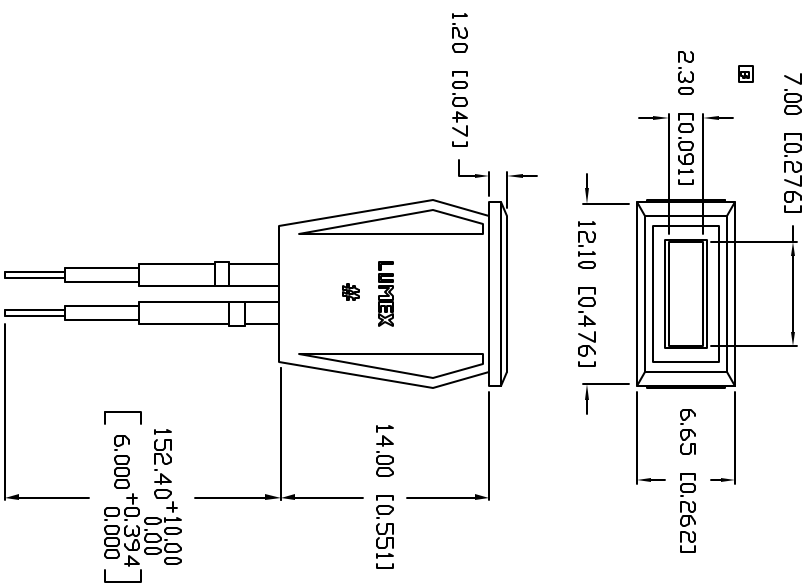

- NOTES:
1. SSI-LXH072 HOLDER. BLACK.
 2. SSL-LX257B36D LED. GREEN.
 3. SECURE LED TO HOLDER WITH UV ACRYLIC.
 4. ANODE LEAD. RED 24 AWG. LXP-WSTZ4RDT0C, CUT 140mm, STRIP 3mm & 9.5mm.
 5. CATHODE LEAD: BLACK 24 AWG. LXP-WSTZ4BLT0C, CUT 140mm, STRIP 3mm & 9.5mm
 6. HEAT SHRINK TUBING. LXP-HEATSHRINK-2, LENGTH 1.5" TYP. (2 PLS.)
 7. PANEL CUT OUT SIZE: 5.3mm x 11.0mm.

ELECTRO-OPTICAL CHARACTERISTICS I_A=25°C I_f=20mA

PARAMETER	MIN	TYP	MAX	UNITS	TEST COND
PEAK WAVELENGTH		565		nm	
FORWARD VOLTAGE		2.2	2.6	V _f	I _f =100µA
REVERSE VOLTAGE		5.0		V _r	I _f =20mA
AXIAL INTENSITY		9		mcd	
VIEWING ANGLE		110		2x theta	
EMITTED COLOR:		GREEN			
EPOXY LENS FINISH:		GREEN DIFFUSED			

LIMITS OF SAFE OPERATION AT 25°C

PARAMETER	MAX	UNITS
PEAK FORWARD CURRENT*	150	mA
STEADY CURRENT	25	mA
POWER DISSIPATION	105	mW
DERATE FROM 25°C	-1.2	mW/°C
OPERATING, STORAGE TEMP.	-40 TO +85	°C
SOLDERING TEMP.	+260	°C
2.0mm FROM BODY		3 SEC. MAX
* I _t <10µs		

*UNLESS OTHERWISE SPECIFIED TOLERANCES PER DECIMAL PRECISION ARE: X=#1 (+0.039), X,Y=#0.5 (+0.020), X,X,Y=#1.25 (+0.010), X,X,X=#0.127 (+0.005), LEAD SIZE=#0.08 (+0.002), LEAD LENGTH=#0.75 (+0.030), MIN=-0.00

PART NUMBER

SSI-LXH072GD-150

565mm GREEN LED, GREEN DIFFUSED LENS,
2.3mm x 7mm RECTANGULAR PANEL INDICATOR LED,
WITH 6" WIRE LEADS.

CONFIDENTIAL INFORMATION

THE INFORMATION CONTAINED IN THIS DOCUMENT IS THE PROPERTY OF LUMEX INC. EXCEPT AS SPECIFICALLY AUTHORIZED IN WRITING BY LUMEX INC., THE HOLDER OF THIS DOCUMENT SHALL KEEP ALL INFORMATION CONTAINED HEREIN CONFIDENTIAL AND SHALL PROTECT SAME IN WHOLE OR IN PART FROM DISCLOSURE AND OSMENATION TO ALL THIRD PARTIES.

RELIABILITY NOTE
OUR MANY YEARS OF EXPERIENCE DATA ACCUMULATION INDICATE THAT SOLDER HEAT IS A MAJOR CAUSE OF EARLY AND FUTURE FAILURE. PLEASE PAY ATTENTION TO YOUR SOLDERING PROCESS.



290 E. HELEN ROAD
PALATINE, IL 60067-6976
PHONE: +1.847.359.2790
US WEB: www.lumex.com
TW WEB: www.lumex.com.tw

DRAWN BY: CT
CHECKED BY:
APPROVED BY:
DATE: 3.16.98
PAGE: 1 OF 1
SCALE: N/A