

UNCONTROLLED DOCUMENT

PART NUMBER
SSI-LXH1090IYW-3

REV.

CAUTION: PRESSURE SENSITIVE ASSEMBLY
AVOID APPLYING PRESSURE TO LED
DURING PANEL ASSEMBLY.

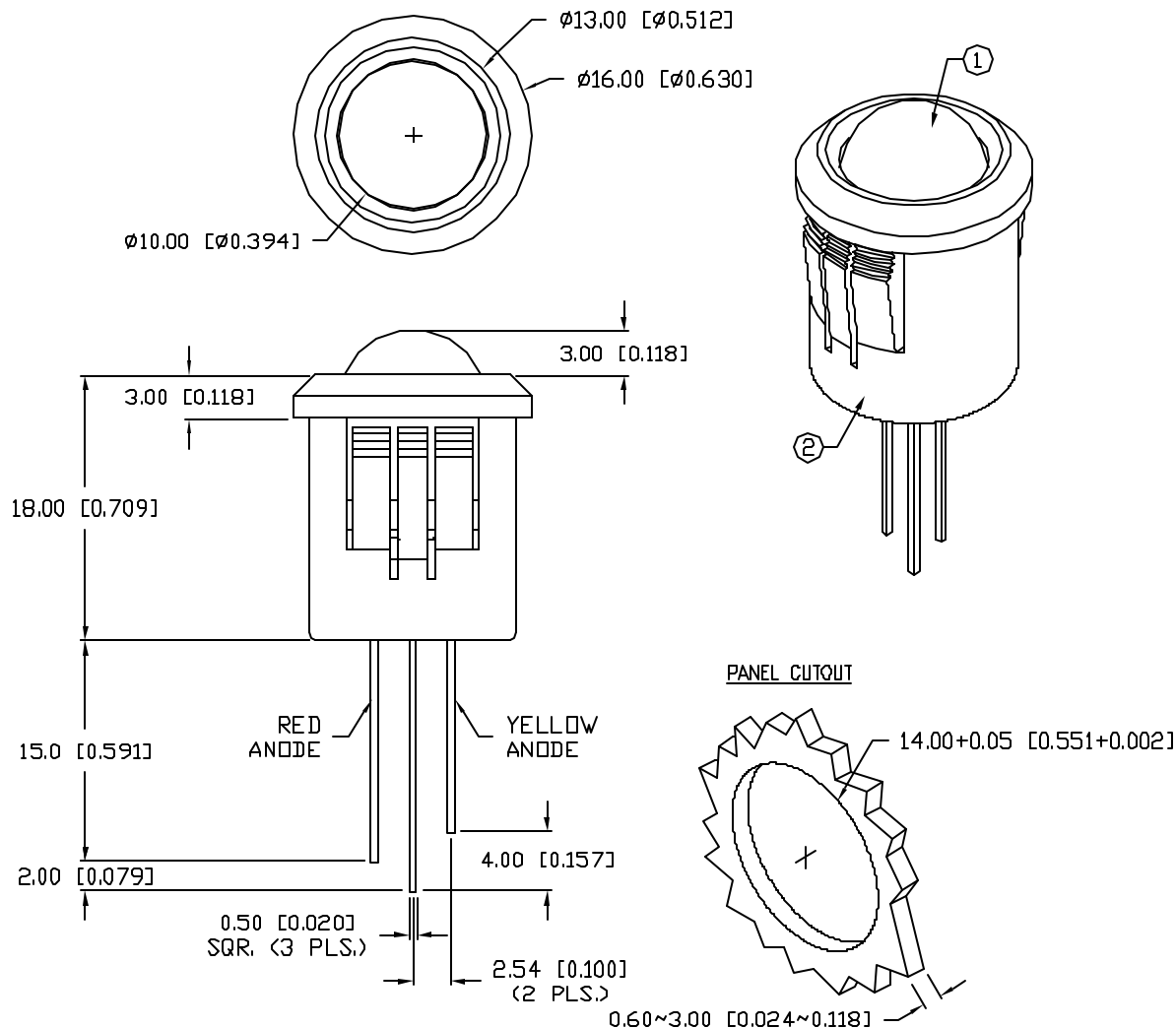

ELECTRO-OPTICAL CHARACTERISTICS $T_A=25^{\circ}\text{C}$ $I_f=20\text{mA}$

PARAMETER	MIN	TYP	MAX	UNITS	TEST COND
PEAK WAVELENGTH		635 (RED)		nm	
		585 (YELLOW)		nm	
FORWARD VOLTAGE (R/Y)		2.1/2.1	2.5/2.5	V_f	
REVERSE VOLTAGE	5.0			V_r	$I_f=100\mu\text{A}$
AXIAL INTENSITY		6		mcd	$I_f=20\text{mA}$
VIEWING ANGLE		60		2x theta	
EMITTED COLOR:	RED/YELLOW				
EPOXY LENS FINISH:	MILKY WHITE DIFFUSED				

LIMITS OF SAFE OPERATION AT 25°C

PARAMETER	COLORS	MAX	UNITS
PEAK FORWARD CURRENT*		150	mA
STEADY CURRENT	(R/Y)	30/30	mA
POWER DISSIPATION		105	mW
DERATE FROM 25°C		-1.2	mW/ $^{\circ}\text{C}$
OPERATING, STORAGE TEMP.		-40 TO +85	$^{\circ}\text{C}$
SOLDERING TEMP.		+260	$^{\circ}\text{C}$
2.0mm FROM BODY			3 SEC. MAX

* $t < 10\mu\text{s}$

NOTES:

1. SSL-LX100139IYW, BICOLOR LED.
2. SSH-RTF1090, BLACK HOLDER.

*UNLESS OTHERWISE SPECIFIED TOLERANCES PER DECIMAL PRECISION ARE: X=±1 (±0.039), XX=±0.5 (±0.020), XXX=±0.25 (±0.010), XXXX=±0.127 (±0.005). LEAD SIZE=±0.05 (±0.002), LEAD LENGTH=±0.75 (±0.030), MIN= $\begin{matrix} +0.00 \\ -0.00 \end{matrix}$ DECIMAL PRECISION MAX.= $\begin{matrix} +0.00 \\ -0.00 \end{matrix}$ DECIMAL PRECISION

UNCONTROLLED DOCUMENT

REV.

PART NUMBER

SSI-LXH1090IYW-3

CONFIDENTIAL INFORMATION

THE INFORMATION CONTAINED IN THIS DOCUMENT IS THE PROPERTY OF LUMEX INC. EXCEPT AS SPECIFICALLY AUTHORIZED IN WRITING BY LUMEX INC, THE HOLDER OF THIS DOCUMENT SHALL KEEP ALL INFORMATION CONTAINED HEREIN CONFIDENTIAL AND SHALL PROTECT SAME IN WHOLE OR IN PART FROM DISCLOSURE AND DISSEMINATION TO ALL THIRD PARTIES.

RELIABILITY NOTE

OUR MANY YEARS OF EXPERIENCE DATA ACCUMULATION INDICATE THAT SOLDER HEAT IS A MAJOR CAUSE OF EARLY AND FUTURE FAILURE. PLEASE PAY ATTENTION TO YOUR SOLDERING PROCESS.



290 E. HELEN ROAD
PALATINE, IL 60067-6976
PHONE: +1.847.359.2790
US WEB: www.lumex.com
TW WEB: www.lumex.com.tw

T-10mm RED/YELLOW LED PANEL INDICATOR,
MILKY WHITE DIFFUSED LENS.

DRAWN BY:

BC

CHECKED BY:

APPROVED BY:

DATE: 1.5.02

PAGE: 1 OF 1

SCALE: N/A