

March 2007

TOUCH CONTROL STEP DIMMER LIGHT SWITCH WITH AUTOMATIC GAIN CONTROL (AGC)

FEATURES:

- Touch Sensitivity guaranteed to 600pF Touch Plate Capacitance.
- Touch Operation independent of line plug polarity.
- Pin selection of three available Brightness Step Sequences.
- Minimal external components.
- AGC Loop stabilizes immediately after Power-Up.
- Brightness state is Off after AC power applied.
- Brightness state is unchanged if AC power interrupted for < 0.5 sec.
- Advanced CMOS design for reliable operating characteristics and low power.
- 50/60 Hz Line Frequency.
- 5V Operation (VDD - VSS).
- LS7541 (DIP); LS7541-S (SOIC) - See Figure 1 -

APPLICATIONS:

- Screw-in and built-in adapter modules for converting table and floor lamps to touch control for step dimming.
- On-Off touch control of under-cabinet fluorescent lamps.
- Wall Switch Step Dimmers

DESCRIPTION:

The LS7541 is a CMOS integrated circuit which provides trigger pulses for triac phase control of incandescent lamps. The circuits are designed to operate with a wide variety of lamp sizes ranging from small table lamps to large floor lamps. The AGC Loop automatically adjusts Touch Sensitivity to be independent of lamp size.

There are 3 different Brightness Step Sequences for each version of the IC which can be selected by the Three-State MODE pin as shown in Table 1.

TABLE 1. BRIGHTNESS STEP MODES

MODE PIN	BRIGHTNESS STEP SEQUENCE
FLOAT	OFF-NIGHT LIGHT-MEDIUM-MAXIMUM-OFF
VDD	OFF-NIGHT LIGHT- LOW MEDIUM-HIGH MEDIUM-MAXIMUM-OFF
VSS	OFF-MAXIMUM-OFF

The lamp brightness is made to vary by changing the delay of the $\overline{\text{TRIG}}$ pulse to the triac from the zero-crossing of the SYNC input. The delays are shown in Table 2 for 50Hz and 60Hz operation along with Delivered Power as a percentage of Full Power. Figure 2 illustrates the delay.

TABLE 2. BRIGHTNESS POWER LEVELS

Brightness	60Hz Delay (1)	50Hz Delay (2)	% PWR (3)
Night Light	6.0 ms	7.2 ms	12
Low Medium	4.8 ms	5.7 ms	35
Medium	4.0 ms	4.8 ms	53
High Medium	3.2 ms	3.8 ms	72
Maximum	0.85 ms	1.0 ms	99

(1) With 400kΩ connected between Pin 1 and VDD.

(2) With 470kΩ connected between Pin 1 and VDD.

(3) Percentage of Full Power delivered to a resistive load by the Triac Switch.

PIN ASSIGNMENT
TOP VIEW

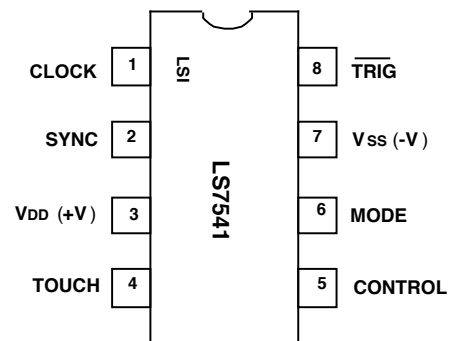
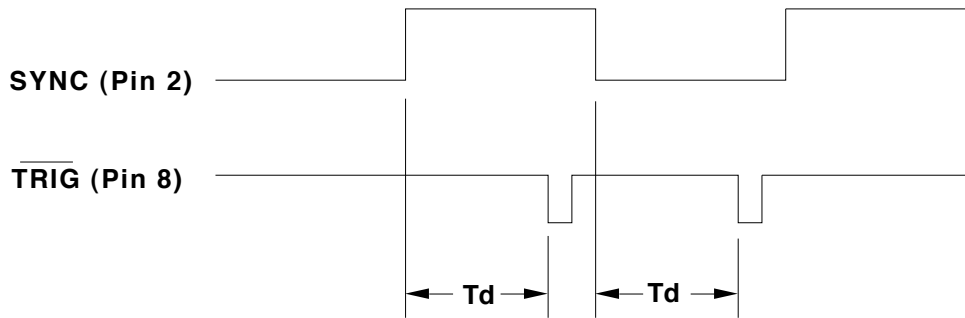

FIGURE 1

FIGURE 2. OUTPUT DELAY (Td)



INPUT/OUTPUT DESCRIPTION:

CLOCK Input (Pin 1)

An external resistor connected between this input and VDD, along with an internal capacitor and oscillator stage, generates a clock which is used for all timing functions. The recommended value of this resistor for 50Hz and 60Hz operation is specified in the ELECTRICAL CHARACTERISTICS. The resistor value determines the Brightness Levels produced. (See Table 2)

SYNC Input (Pin 2)

50 or 60Hz AC input for zero crossing detection.

VDD (Pin 3)

Supply voltage positive terminal.

TOUCH Input (Pin 4)

Input for sensing that a touch has been made on a lamp surface or other touch plate.

CONTROL I/O (Pin 5)

An external R-C network connected between this pin and VDD establishes the controlling feedback for the AGC Loop.

MODE Input (Pin 6)

A three-state input used to select the desired Brightness Step Sequence (See Table 1).

VSS (Pin 7)

Supply voltage negative terminal.

TRIG (Pin 8)

The TRIG output produces a negative going pulse every half-cycle of the SYNC input to trigger the triac. The delay, Td, of the pulse with respect to the SYNC signal determines the Brightness Level produced. (See Table 2 & Figure 2)

ABSOLUTE MAXIMUM RATINGS:

PARAMETER	SYMBOL	VALUE	UNIT
DC supply voltage	VDD - VSS	+7	V
Any input voltage	VIN	VSS - 0.5 to VDD + 0.5	V
Operating temperature	TA	-20 to +85	°C
Storage temperature	TSTG	-65 to +150	°C

The information included herein is believed to be accurate and reliable. However, LSI Computer Systems, Inc. assumes no responsibilities for inaccuracies, nor for any infringements of patent rights of others which may result from its use.

ELECTRICAL CHARACTERISTICS:

(All voltages referenced to Vss. TA = +25°C unless otherwise specified.)

PARAMETER	SYMBOL	MIN	TYP	MAX	UNIT	CONDITIONS
Supply Voltage	VDD	+4.5	-	+5.5	V	-
Supply Current	IDD	-	-	1.0	mA	Output off, VDD = +5.0V
$\overline{\text{TRIG}}$ Sink Current Vo = VDD - 3V	Io	-50	-	-	mA	VDD = +5.0V
$\overline{\text{TRIG}}$ Source Current Vo = VDD - 0.2V	Io	+0.1	-	-	mA	VDD = +5.0V
$\overline{\text{TRIG}}$ Pulse Width	Tw	-	100	-	μs	Rc = 400k Ω , 60Hz
		-	115	-	μs	Rc = 470k Ω , 50Hz
$\overline{\text{TRIG}}$ Pulse Delay (Medium Brightness)	Td	-	4.0	-	ms	Rc = 400k Ω , 60Hz
		-	4.8	-	ms	Rc = 470k Ω , 50Hz
CLOCK Resistor	Rc	-	400	-	k Ω	60Hz
		-	470	-	k Ω	50Hz
CONTROL Resistor	-	-	10	-	M Ω	-
		-	1	-	μF	-
Capacitor	-	-	-	-	-	-
Touch Plate Capacitance	CL	-	-	600	pF	-

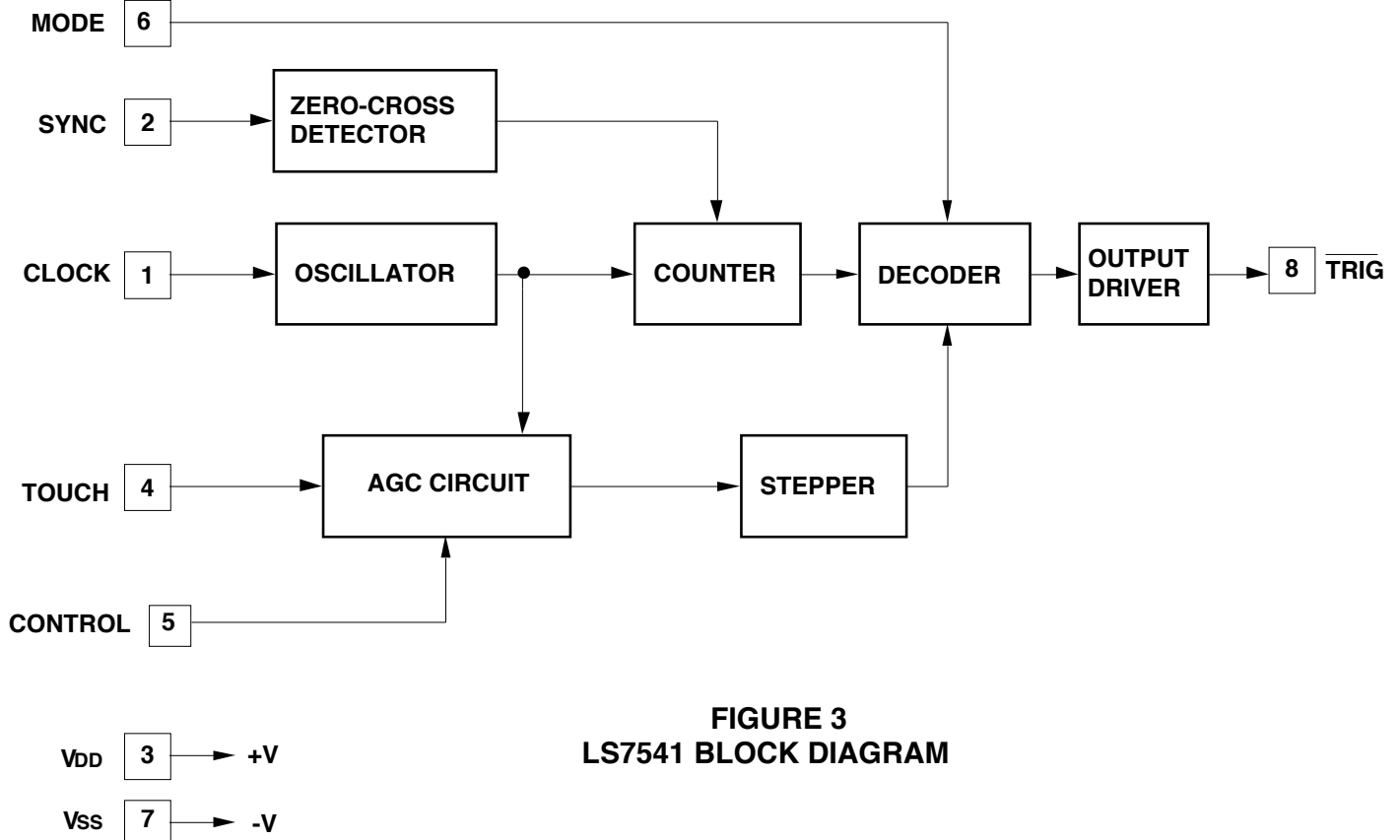

**FIGURE 3
LS7541 BLOCK DIAGRAM**

FIGURE 4. TOUCH LAMP APPLICATION SCHEMATIC

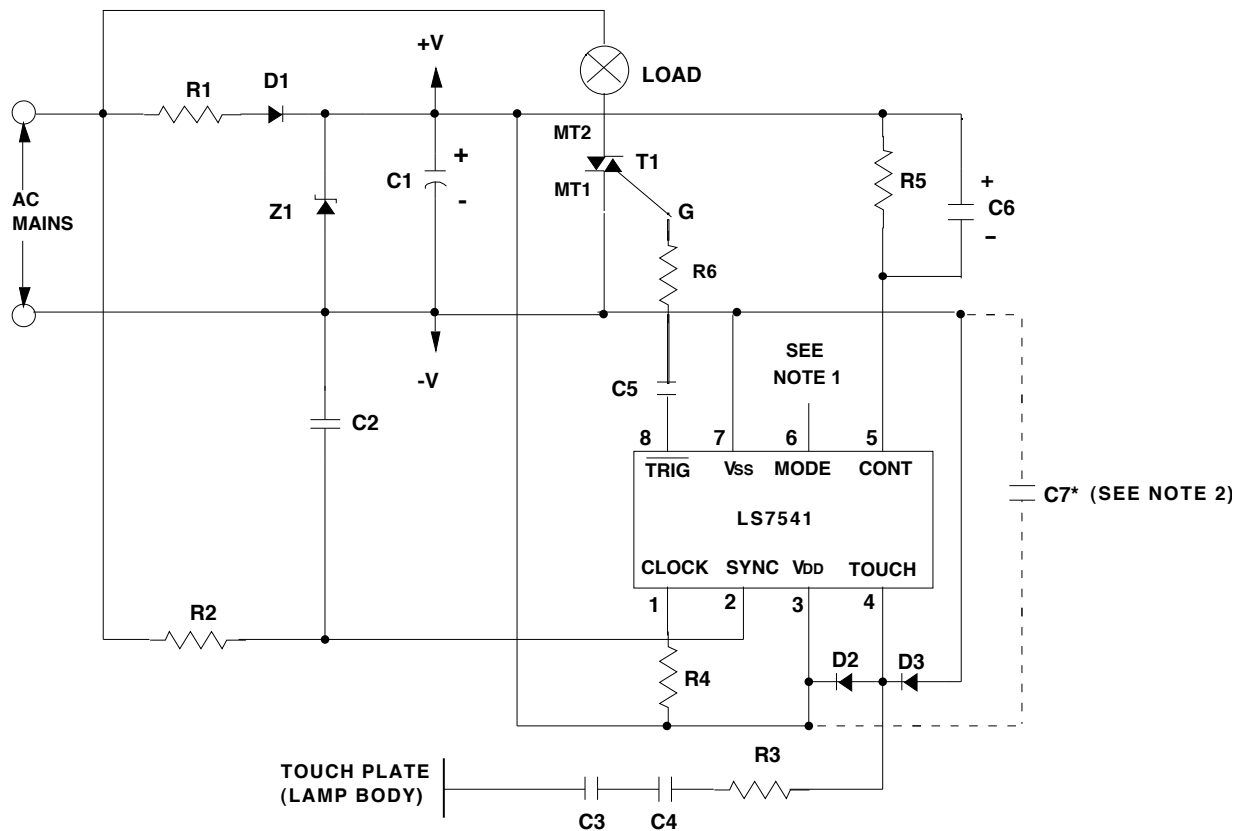

115VAC APPLICATION

220VAC APPLICATION

- R1 = 20kΩ, 1W
- R2 = 470kΩ, 1/4W
- R3 = 1kΩ, 1/4W
- (1) R4 = 400kΩ, 1/4W, 1%
- R5 = 10MΩ, 1/4W
- R6 = 100Ω, 1/4W
- C1 = 47μF, 10V
- C2 = 1000pF, 10V
- C3 = 1000pF, 1kV
- C4 = 1000pF, 1kV
- C5 = 0.03μF, 10V
- C6 = 1μF, 10V
- Z1 = 5.1V, 1/4W Zener
- D1 = 1N4004
- D2 = 1N4148
- D3 = 1N4148
- T1 = Q2004L4 (Typical Triac) or Q2004F41 (Typical Triac)

- R1 = 39kΩ, 2W
 - R2 = 910kΩ, 1/4W
 - (1) R4 = 470kΩ, 1/4W, 1%
 - D1 = 1N4005
 - T1 = Q4004L4 (Typical Triac) or Q4004F41 (Typical Triac)
- All other values remain the same.

(1) Resistor should be placed adjacent to Pin 1.

NOTE 1: Connect MODE (Pin 6) for desired Brightness Step Sequence (See Table 1).

NOTE 2: A good PCB layout using through-hole components will provide protection for ESD introduced at the Touch Plate in the range of 25kV. Using surface mount components and/or a poor PCB layout can reduce the ESD protection. The OEM can increase the ESD protection provided by the product with any combination of the following steps:

Step 1: The most effective and least costly way to increase ESD protection is to create a spark gap around the Touch Plate input on the PCB. This will increase ESD protection on a good PCB layout to about 35kV. The gap should be made with a split metal ring with each side of the metal ring connected back to opposite sides of the AC line. This ensures that a path for the spark back to house ground through AC Neutral exists independent of line plug polarity. The split ring and the center conduction plate should be constructed so that the spacing between them conforms to UL requirements. The spark gap will absorb most of the ESD leaving a remnant of about 10kV for the rest of the circuit to absorb.

Step 2: Increase R3 from 1kΩ to 5.1kΩ and add C7, a 0.1μF capacitor, between VDD and Vss. (A minimal loss in touch sensitivity may be experienced.)

Step 3: Replace diodes D2 and D3 (1N4148) with Schottky diodes (1N5819 or similar)

FIGURE 5. TOUCH LAMP APPLICATION SCHEMATIC

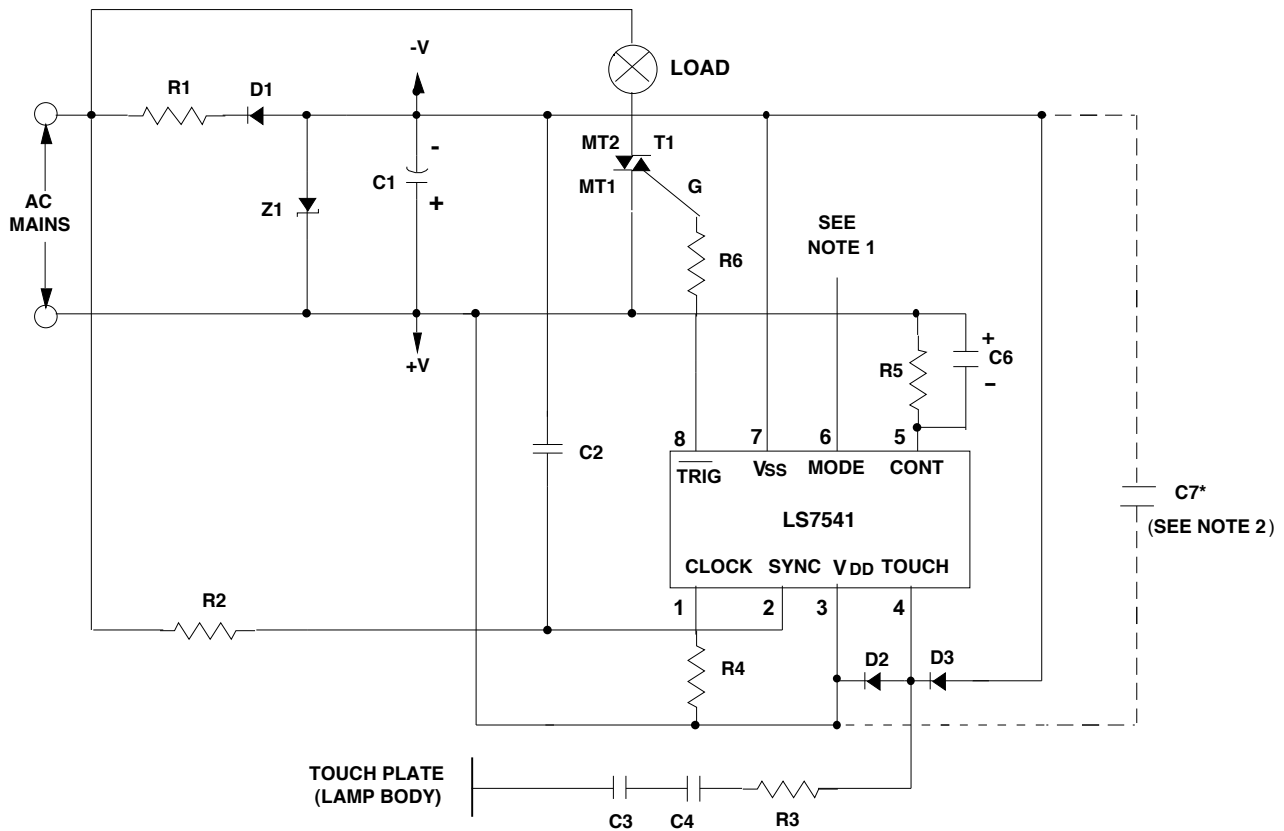

The Figure 5 Application Schematic functions identically to that shown in Figure 4 with one less component. Referencing Triac T1 to the +V power supply of the IC eliminates the need to AC couple the TRIAC pulse to the Triac Gate thereby eliminating component C5.

FIGURE 6. PUSHBUTTON APPLICATION SCHEMATIC

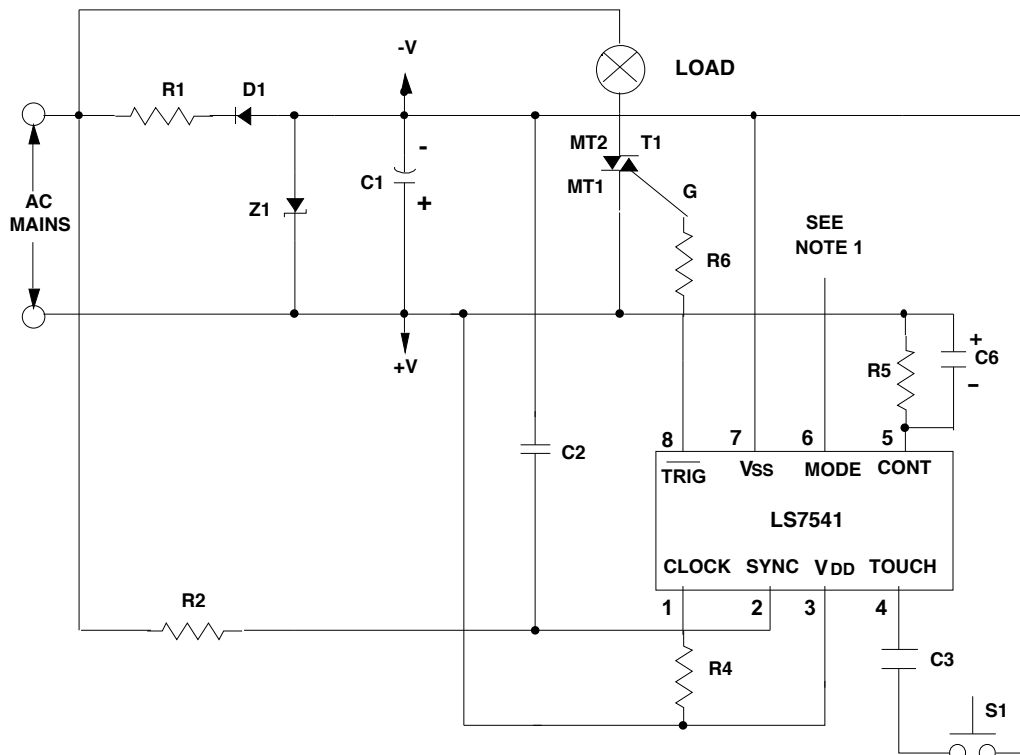

Using the Figure 5 schematic as an example, components R3, C4, C7, D1 and D2 are eliminated and Pushbutton Switch, S1, is connected from one end of C3 to Vss. Each depression of S1 causes the Brightness Level to change in the same way as a Touch does in Figure 5. C3 is 1000pf, 10V capacitor.

FIGURE 7. A Touch Wall Switch Step Dimmer Using the LS7541 IC.

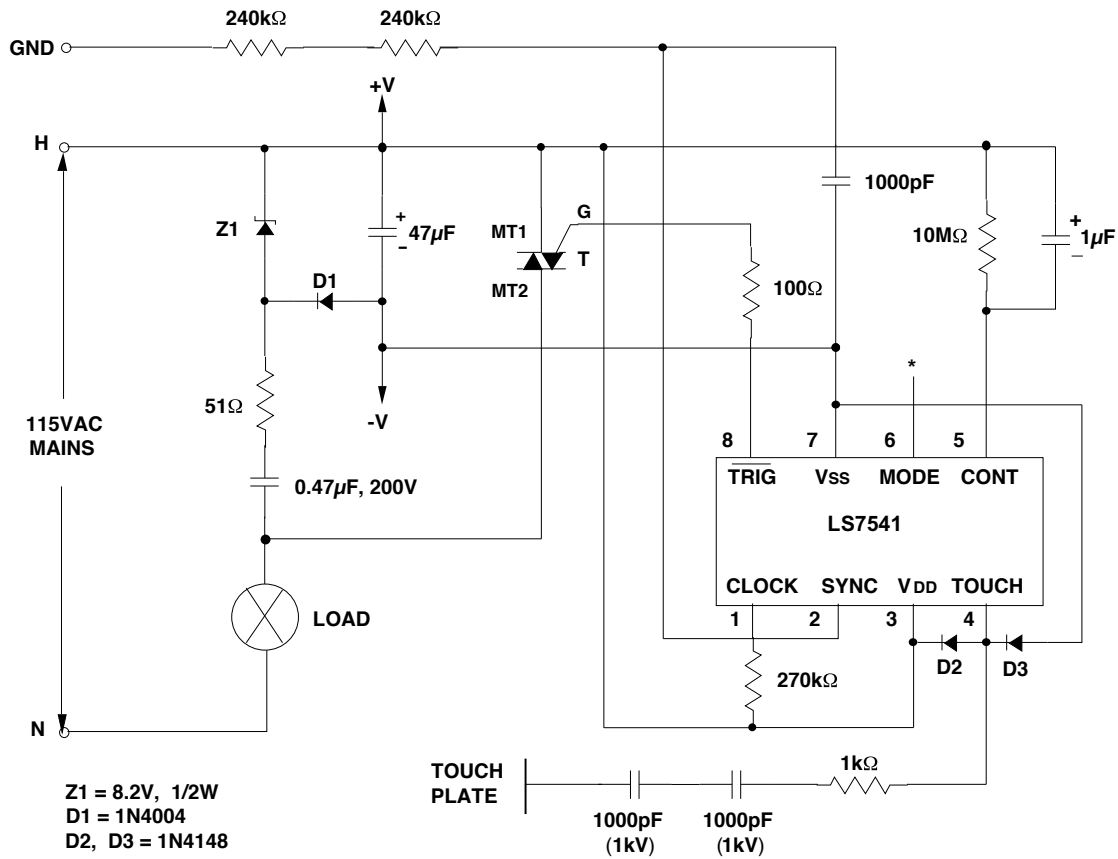

* Connect to VDD, Vss or Float according to desired operation.
 All resistors 1/4W, Capacitors 10V, unless otherwise noted

FIGURE 8. A Pushbutton Wall Switch Step Dimmer Using the LS7541 IC.

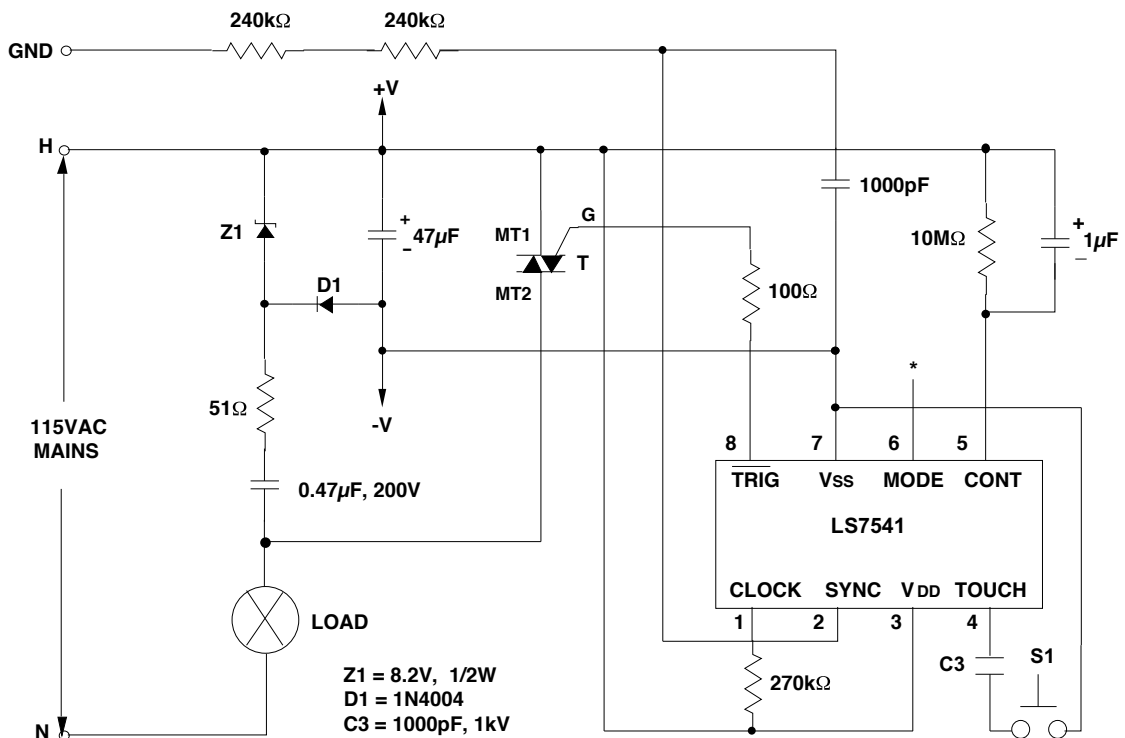

* Connect to VDD, Vss or Float according to desired operation.
 All resistors 1/4W, Capacitors 10V, unless otherwise noted