

5-SPEED AC MOTOR CONTROLLER / 5-STEP LAMP DIMMER

January 2009

FEATURES:

- Inputs/Outputs for selecting and displaying 5 speed/power levels
Electronically latched inputs with dome switch compatibility
- Separate Boost input for full-speed/power selection
- Separate Pulse input for periodic on/off cycle selection
- +6V Operation (VDD - VSS)
- **LS7317** (DIP); **LS7317-S** (SOIC) - See Figure 1 -

Applications:

- Consumer Appliances such as Blenders, Range Hoods, Fans, etc.
- Lamp Dimmer for control of high-voltage lamps and electronic-transformer coupled low-voltage lamps such as Halogen Lamps.

DESCRIPTION:

The LS7317 is a MOS circuit for controlling the speed of an AC motor. Five inputs, PL1/ through PL5/ are provided to select five speed/power levels between 40% and 96% of full power. A BOOST/ input is provided to override any selected power level with a jump to 99% of full power.

A PULSE/ input provides for periodic two seconds on, two seconds off auto-pulse cycle for one minute. All these inputs require momentary activation which can very conveniently be produced by push-button dome or leaf switches. When a logic low is applied through such a push-button switch to any of the speed inputs or the Pulse input, the input becomes active and switches state to become an output for driving an external LED and display the selected speed level. A TRIG/ output is also turned on to drive the trigger input of a triac in series with the motor and control its speed by controlling the firing angle of the triac. Phase synchronization of the external AC and the triac trigger is made with an internal PLL, with the AC signal being applied to the SYNC input of the LS7317. An OFF/ input is provided for turning the motor off with a momentary push-button switch.

The LS7317 can also be used as a Lamp Dimmer providing 5 selectable intensity levels as indicated in the application schematic shown in Figure 5. The **LOAD** can be either a high voltage lamp or the input to an electronic-transformer coupling to a low-voltage lamp. In the Lamp Dimmer application, the Pulse/ and Boost/ inputs are not used

INPUTS/OUTPUTS

PL1/ - PL5/ (Pin 1 - Pin 5)

Five inputs/outputs for selecting five speed/power levels. When no power level is selected, such as upon a system power-up, PL1/ - PL5/ all act as inputs. When a power level is selected by applying a logic low at one of these inputs for the duration of TH (see Transient Characteristics section), the output TRIG/ is turned on at the selected phase angle and the PL/ input switches state to become a current-sinking output in order to drive a display, such as an LED. It switches back to the input state when another PL/ input or the OFF/ input is activated.

Power levels and triac conduction angles referenced to the SYNC input (Pin 10) for each PL/ and Boost/ are shown in Table 1.

TABLE 1

	PL1/	PL2/	PL3/	PL4/	PL5/	BOOST/
% of Full Power:	40%	55%	69%	82%	96%	99%
Conduction Angle	81°	95°	108°	122°	147°	160°

CONNECTION DIAGRAM - TOP VIEW

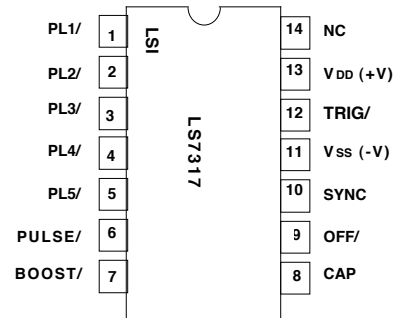

FIGURE 1

PULSE/ (Pin 6)

A logic low applied to the PULSE/ input initiates the auto-pulse cycle and causes the PULSE/ input to switch from an input to an output state. Subsequently, when a speed level is selected, the TRIG/ output is turned on for two seconds, then turned off for two seconds. The two second on, two second off cycle is repeated for one minute. At the end of one minute the auto-pulse cycle is terminated with the TRIG/ output off and the PULSE/ pin reverting back to the input state.

BOOST/ (Pin 7)

A logic low applied to the BOOST/ input causes the TRIG/ output to be turned on at the maximum conduction angle, corresponding to 99% of full power. The boost state overrides any prevalent state and continues as long as the BOOST/ input is held at logic low. Upon returning BOOST/ to logic high, the circuit returns to and continues in the pre-Boost state.

OFF/ (Pin 9)

A logic low applied to the OFF/ input turns the TRIG/ output off, aborts any auto-pulse cycle in progress and causes any active PL/ pin or the PULSE/ pin to switch from the output to the input state.

CAP (Pin 8)

Input for the PLL external filter capacitor connection.

SYNC (Pin 10)

Input for the PLL 50Hz/60Hz AC reference signal. All internal timings are synchronized with the SYNC input.

TRIG/ (Pin 12)

The TRIG/ output is designed to drive the gate of a triac connected in series with the load. When on, the TRIG/ output produces a 1.2ms/1ms wide negative pulse in each half-cycle of the 50Hz/60Hz AC at a predefined phase angle which corresponds to the selected speed level. When off, TRIG/ sits at logic high.

V_{DD} (Pin 13)
Supply voltage positive terminal.

V_{SS} (Pin 11)
Supply voltage negative terminal.

FIGURE 2. TRIG/ PHASE ANGLE, \emptyset

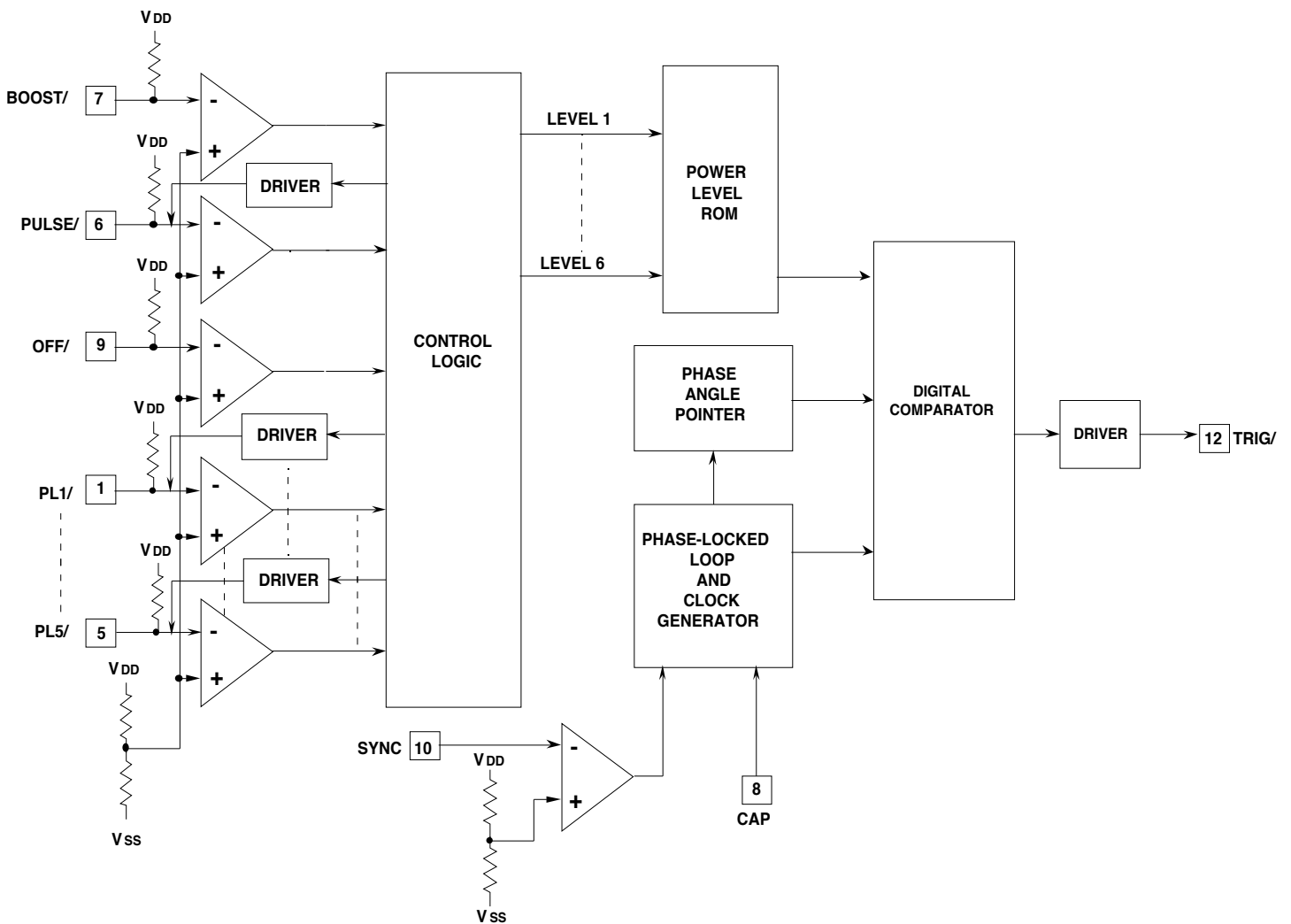
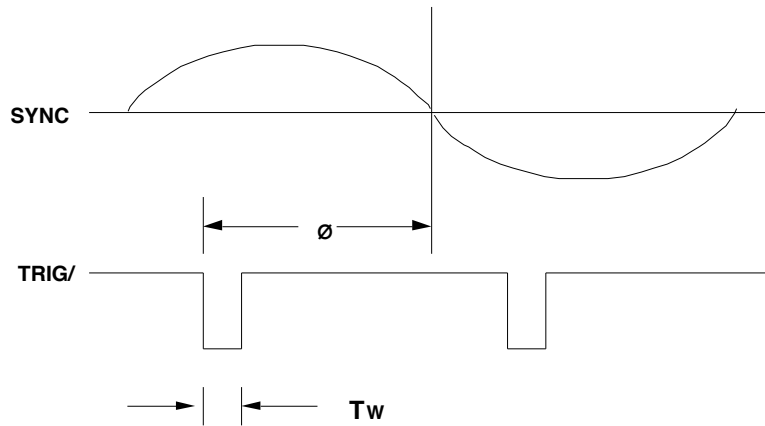

FIGURE 3. LS7317 BLOCK DIAGRAM

MAXIMUM RATINGS:

PARAMETER	SYMBOL	VALUE	UNIT
Storage Temperature	TSTG	-65 to +150	°C
Operating Temperature	TA	0 to +80	°C
DC Supply Voltage	VDD - VSS	+7	V
Any Input Voltage	VIN	VDD - 0.3 to VSS + 0.3	V

DC ELECTRICAL CHARACTERISTICS:

(TA = 25°C, all voltages referenced to VSS)

	SYMBOL	MIN	TYP	MAX	UNIT	CONDITION
Supply Voltage	VDD	+5.4	+6	+6.6	V	-
Supply Current	IDD	-	160	200	µA	VDD = 6V, outputs off
Input Voltage:						
SYNC, LO	VISL	0	-	1/3VDD	V	-
SYNC, HI	VISH	2/3VDD	-	VDD	V	-
All other inputs, LO	VIL	0	-	1/4VDD	V	-
All other inputs, HI	VIH	1/2VDD	-	VDD	V	-
Input Current:						
SYNC Input	IH	-	-	110	µA	With Series 1.5MΩ Resistor to 115VAC
Input Pull-up Resistance:						
PL/, OFF/, RUN/, PULSE/	RIN	50	100	200	kΩ	-
Output Voltage:						
TRIG/, HI	VOH	VDD	-	-	V	-
TRIG/, LO	VOL	-	VSS	-	V	-
Output Current:						
TRIG/, Sink	Ios	-35	-	-	mA	VDD = +6V VOL = +3V
PL/ Sink	IOPL	-5	-	-	mA	VOPL = +1V

DYNAMIC CHARACTERISTICS:

	SYMBOL	MIN	TYP	MAX	UNIT	CONDITION
SYNC frequency	fs	40	-	70	Hz	-
PL/, RUN/, PULSE/, OFF/ Hold time	TH	50	-	infinite	ms	60Hz SYNC
	TH	60	-	infinite	ms	50Hz SYNC
TRIG/ Pulse Width	Tw	-	1.0	-	ms	60Hz SYNC
	Tw	-	1.2	-	ms	50Hz SYNC

The information included herein is believed to be accurate and reliable. However, LSI Computer Systems, Inc. assumes no responsibilities for inaccuracies, nor for any infringements of patent rights of others which may result from its use.

FIGURE 4. 5-SPEED BLENDER CONTROLLER APPLICATION

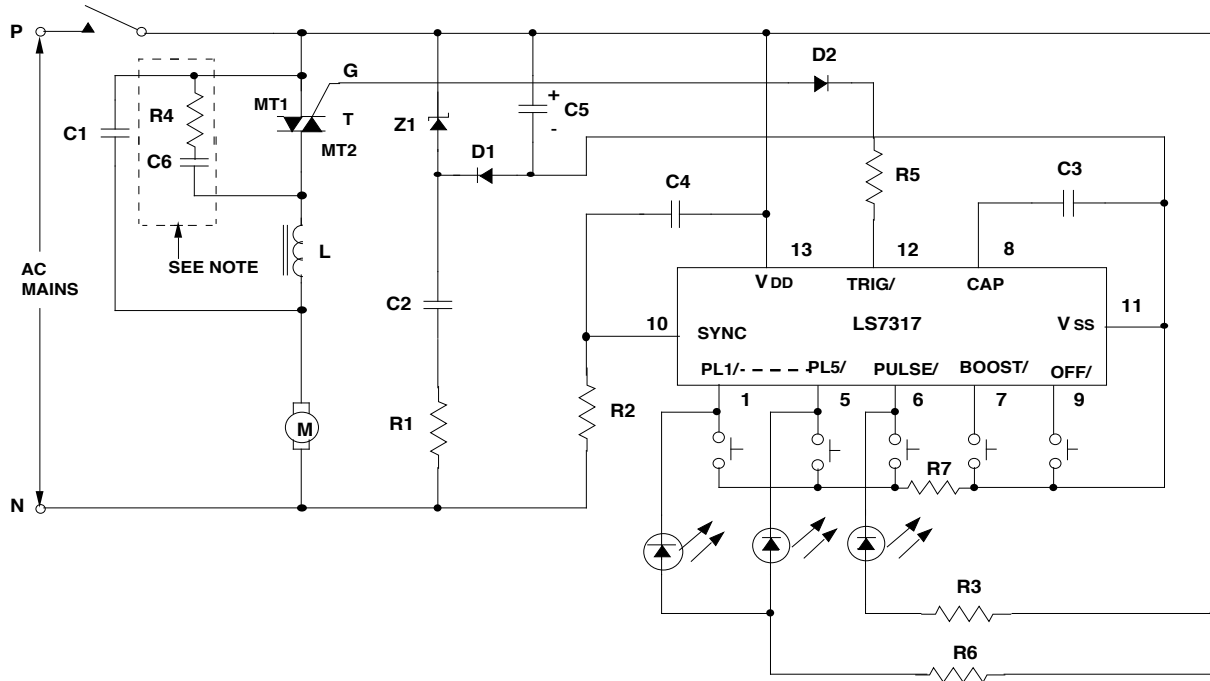

NOTE: R4-C6 Snubber network and/or C7 may be required for certain motors.

- | | | |
|---|---------------------------------|---------------------------------|
| C1 = 0.15 μ F, 200V (400V)* | R1 = 56 Ω , 1/2W | R7 = 390 Ω |
| C2 = 0.68 μ F, 200V (0.47 μ F, 400V)* | R2 = 1.5M Ω | L = 100 μ H (200 μ H) |
| C3 = 0.022 μ F | R3 = 1k Ω (For 5mA LEDs) | Z1 = 6.8V \pm 5%, 1W |
| C4 = 470pF | R4 = 1.8k Ω , 1W (2W)* | D1, D2 = 1N4148 |
| C5 = 470 μ F | R5 = 100 Ω | T = Q2006L4 (Q4006L4)*, Typical |
| C6 = 0.47 μ F, 200V (400V)* | R6 = 1k Ω | |
- All resistors 1/4W, all capacitors 25V unless otherwise specified. *Indicates component change for 220VAC Mains.

FIGURE 5. 5 - INTENSITY LEVEL LIGHT DIMMER APPLICATION

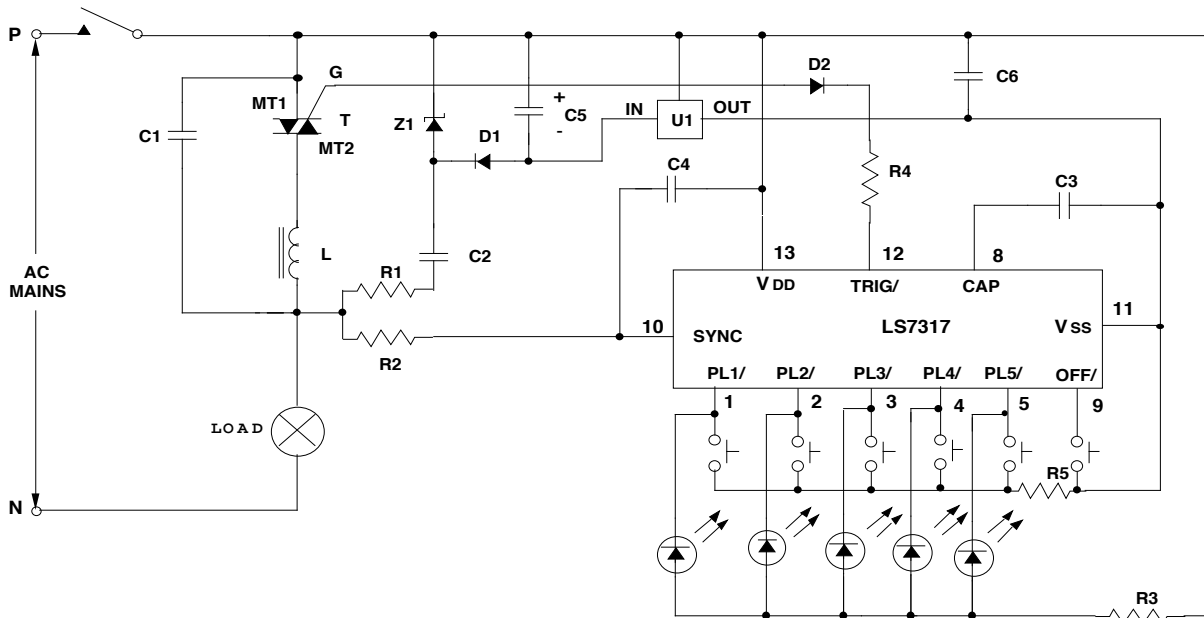

- | | | |
|--|---------------------------------|---------------------------------------|
| C1 = 0.15 μ F, 200V (400V)* | R1 = 56 Ω , 1W | L = 100 μ H (200 μ H)* |
| C2 = 1.0 μ F, 200V (0.82 μ F, 400V)* | R2 = 1.5M Ω | Z1 = 10V \pm 5%, 1W |
| C3 = 0.022 μ F | R3 = 1k Ω (For 5mA LEDs) | D1, D2 = 1N4148 |
| C4 = 470pF | R4 = 100 Ω | T = Q2006L4 (Q4006L4)*, Typical |
| C5 = 220 μ F | R5 = 390 Ω | U1 = L79L06 Regulator (or equivalent) |
| C6 = 25 μ F, 10V | | |

All resistors 1/4W, all capacitors 25V unless otherwise specified. *Indicates component change for 220VAC Mains.