

700mA High Speed Dual LDO Regulator

■ GENERAL DESCRIPTION

The XCM406A series is a high current, dual LDO regulator in an ultra small USP-12B01 package which measures just 2.8mm x 2.3mm. The IC is basically two XC6210 high speed CMOS LDOs which are precise, low noise, high current, regulators consisting of a voltage reference, an error amplifier, a current limiter and phase compensation circuit plus a driver transistor. The low ON resistance of the built-in driver transistor means that batteries can be used to a minimal input-output voltage differential and can therefore be used for a longer time. The series can be used with low ESR ceramic capacitors and output voltages are selectable in 0.05V increments within a range of 0.8V to 5.0V per channel. The fold-back current limit circuit also operates as the output current limiter and the output pin protector.

The IC can be placed in stand-by mode via the CE function so that power consumption is greatly reduced.

■ APPLICATIONS

- Mobile phone
- Bluetooth equipment
- Portable AV equipment
- Portable gaming equipment

■ FEATURES

Maximum Output Current	: 700mA (TYP. 800mA limit) ($1.6V \leq V_{OUT} \leq 5.0V$)
Dropout Voltage	: 50mV@ $I_{OUT}=100mA$
Operating Voltage Range	: 1.5V ~ 6.0V
Output Voltage Setting Range	: 0.8V ~ 5.0V (0.05V increments)
Accuracy	: $\pm 2\%$
Low Power Consumption	: 35 μA (TYP.)
High Ripple Rejection	: 60dB @ 1kHz
Operating Temperature Range	: - 40 °C ~ 85 °C
Package	: USP-12B01
Environmentally Friendly	: EU RoHS Compliant, Pb Free

■ TYPICAL APPLICATION CIRCUIT

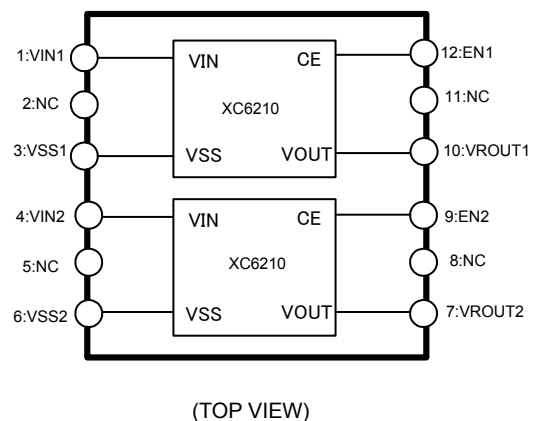
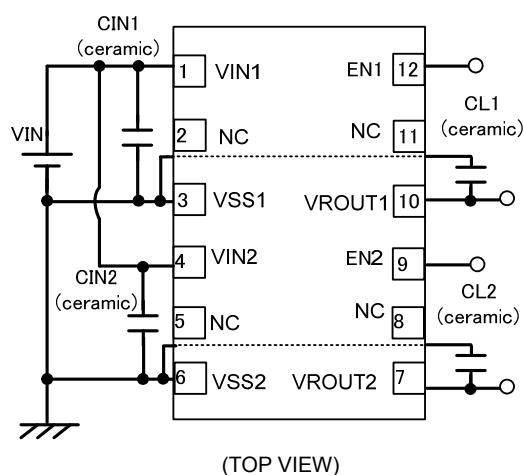

* The dotted lines in the circuit indicates the connection using through-holes at the backside of the PC board

PIN CONFIGURATION

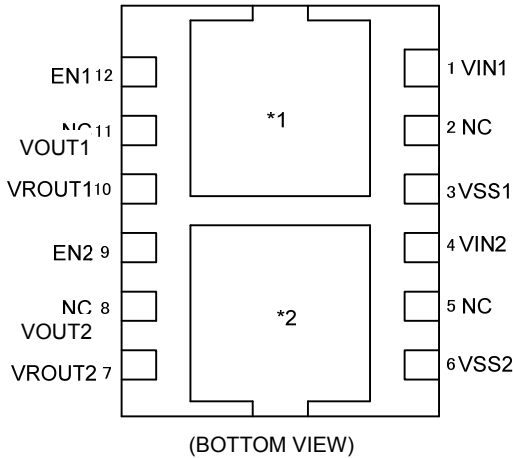

PIN ASSIGNMENT

PIN NUMBER	XCM406A	FUNCTION
1	V _{IN1}	Power Input1
2	NC	No Connection
3	V _{SS1}	Ground1
4	V _{IN2}	Power Input2
5	NC	No Connection
6	V _{SS2}	Ground2
7	V _{OUT2}	Output2
8	NC	No Connection
9	EN2	ON/OFF Control2
10	V _{OUT1}	Output1
11	NC	No Connection
12	EN1	ON/OFF Control1

* A dissipation pad on the reverse side of the package is electrically isolated.

*1: Electrical potential of the XC6210 series' dissipation pad should be the V_{SS} level.

*2: Electrical potential of the XC6210 series' dissipation pad should be the V_{SS} level.

Care must be taken for an electrical potential of each dissipation pad so as to enhance mounting strength and heat release when the pad needs to be connected to the circuit.

PIN LOGIC CONDIFION

PIN NAME	DESIGNATOR	CONDITIONS
EN1/EN2	H	$1.3V \leq V_{EN} \leq 6.0V$
	L	$V_{EN} \leq 0.25V$

PIN FUNCTION ASSIGNMENT

XCM410AA Type (EN High Active, Without EN Pull-down)

EN1/EN2 LEVEL	IC OPERATION
HIGH	ON
LOW	OFF
OPEN	Undefined state

XCM410AB Type (EN High Active, With EN Pull-down)

EN1/EN2 LEVEL	IC OPERATION
HIGH	ON
LOW	OFF
OPEN	

PRODUCT CLASSIFICATION

Ordering Information

XCM406A①②③④⑤⑥^(*)

DESIGNATOR	ITEM	SYMBOL	DESCRIPTION
①	TYPE	A	Without Pull-down resistor
		B	With Pull-down resistor
②③	Output Voltages ^(*)	01	V _{OUT1} =1.3V, V _{OUT2} =1.5V
		02	V _{OUT1} =1.8V, V _{OUT2} =3.3V
		03	V _{OUT1} =2.5V, V _{OUT2} =3.3V
		04	V _{OUT1} =3.3V, V _{OUT2} =1.5V
④⑤⑥ ^(*)	Package (Oder Unit)	DR	USP-12B01 (3,000/Reel)
		DR-G	USP-12B01 (3,000/Reel)

^(*) The "-G" suffix indicates that the products are Halogen and Antimony free as well as being fully RoHS compliant.

⁽²⁾The XCM406 series are semi-custom products. V_{OUT1} and V_{OUT2} voltage setting range is 0.8V to 5.0V in 0.05V increments.

For other combinations, output voltages and etc., please ask your sales contacts.

■ BLOCK DIAGRAMS

● XCM406

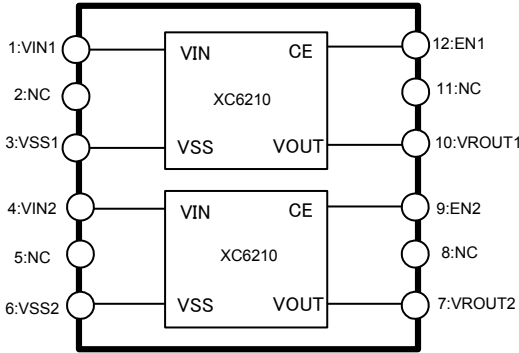

● XC6210

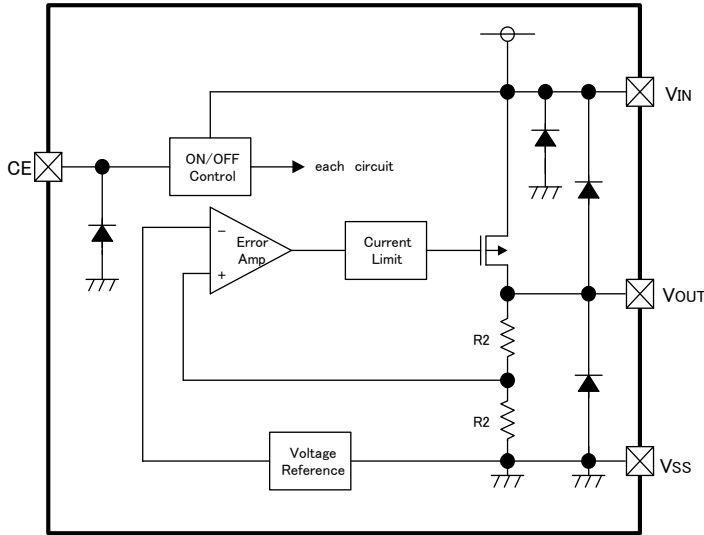

*Diodes inside the circuit are an ESD protection diode and a parasitic diode.

■ ABSOLUTE MAXIMUM RATINGS

PARAMETER	SYMBOL	RATINGS	UNITS
Input Voltage	V_{IN}	6.5	V
Output Current *	I_{OUT}	900	mA
Output Voltage	V_{OUT}	$V_{SS} - 0.3 \sim V_{IN} + 0.3$	V
EN Voltage	V_{CE}	$V_{SS} - 0.3 \sim 6.5$	V
Power Dissipation	USP-12B01	150	mW
Junction Temperature	T_j	125	°C
Ambient Temperature Range	T_{opr}	- 40 ~ + 85	°C
Storage Temperature Range	T_{stg}	- 55 ~ + 125	°C

※1. $Pd > \{(V_{IN1} - V_{OUT1}) \times I_{OUT1} + (V_{IN2} - V_{OUT2}) \times I_{OUT2}\}$

ELECTRICAL CHARACTERISTICS

● XCM406AA/AB Series (VR1.VR2)

Ta=25 °C

PARAMETER	SYMBOL	CONDITIONS	MIN.	TYP.	MAX.	UNITS	CIRCUIT	
Output Voltage ^(*) , ^(**)	V _{OUT(E)}	V _{IN} =V _{OUT(T)} +1.0V, I _{OUT} =30mA, V _{EN} =V _{IN} (V _{OUT(T)} >1.50V)	×0.98	V _{OUT(T)}	×1.02	V	①	
		V _{IN} =V _{OUT(T)} +1.0V, I _{OUT} =30mA, V _{EN} =V _{IN} (V _{OUT(T)} ≤1.50V)	-30mV	V _{OUT(T)}	+30mV			
Maximum Output Current	I _{OUTMAX}	V _{IN} =V _{OUT(T)} +1.0V, V _{EN} =V _{IN} (V _{OUT(T)} >1.50V)	700	-	-	mA	①	
		V _{IN} =V _{OUT(T)} +1.0V, V _{EN} =V _{IN} (V _{OUT(T)} ≤1.50V)	500	-	-			
Load Regulation	ΔV _{OUT}	1mA≤I _{OUT} ≤100mA, V _{EN} =V _{IN}	-	15	60	mV	①	
Dropout Voltage ^(*)	V _{dif1}	I _{OUT} =30mA, V _{EN} =V _{IN}	E-1			mV	①	
	V _{dif2}	I _{OUT} =100mA, V _{EN} =V _{IN}	E-2			mV	①	
Supply Current	I _{DD}	V _{IN} =V _{EN} =V _{OUT(T)} +1.0V	(XCM406AA)	-	35	55	μA	②
			(XCM406AB)	E-3				
Stand-by Current	I _{STB}	V _{IN} =6.0V, V _{EN} =V _{IN}	-0.10	-	0.10	μA	②	
Line Regulation	ΔV _{OUT} / ΔV _{IN} ·V _{OUT}	V _{OUT(T)} +1.0V≤V _{IN} ≤6.0V V _{EN} =V _{IN} , I _{OUT} =30mA (V _{OUT(T)} <4.50V)	-	0.01	0.20	% / V	①	
		5.5V≤V _{IN} ≤6.0V V _{EN} =V _{IN} , I _{OUT} =30mA (V _{OUT(T)} ≥4.50V)						
Input Voltage	V _{IN}		1.5	-	6.0	V	-	
Output Voltage Temperature Characteristics	ΔV _{OUT} / ΔT _{opr} ·V _{OUT}	I _{OUT} =30mA, V _{EN} =V _{IN}	-	±100	-	ppm / □	①	
		-40°C≤T _{opr} ≤85°C						
Ripple Rejection Rate	PSRR	V _{IN} =[V _{OUT(T)} +1.0]V _{DC} +0.5V _{P-PAC} V _{EN} =V _{IN} , I _{OUT} =30mA, f=1kHz (V _{OUT(T)} <4.75V)	-	60	-	dB	③	
		V _{IN} =5.75V _{DC} +0.5V _{P-PAC} V _{EN} =V _{IN} , I _{OUT} =30mA, f=1kHz (V _{OUT(T)} ≥4.75V)						
Current Limiter	I _{LIM}	V _{IN} =V _{OUT(T)} +1.0V, V _{EN} =V _{IN} (V _{OUT(T)} >1.50V)	700	800	-	mA	①	
		V _{IN} =V _{OUT(T)} +1.0V, V _{EN} =V _{IN} (V _{OUT(T)} ≤1.50V)	-	800	-			
Short-Circuit Current	I _{SHORT}	V _{IN} =V _{OUT(T)} +1.0V, V _{EN} =V _{IN}	-	50	-	mA	①	
EN "High" Level Voltage	V _{ENH}		1.3	-	6.0	V	①	
EN "Low" Level Voltage	V _{ENL}		-	-	0.25	V	①	
EN "High" Level Current	I _{ENH}	V _{IN} =V _{EN} =V _{OUT(T)} +1.0V	(XCM406AA)	-0.10	-	0.10	μA	①
			(XCM406AB)	E-4				
EN "Low" Level Current	I _{ENH}	V _{IN} =V _{OUT(T)} +1.0V, V _{EN} =V _{SS}	-0.10	-	0.10	μA	①	

NOTE:

*1: Unless otherwise stated, V_{IN}=V_{OUT(T)}+1.0V

*2: V_{OUT(T)}=Specified output voltage

*3: V_{OUT(E)}=Effective output voltage

(i.e. the output voltage when "V_{OUT(T)}+1.0V" is provided while maintaining a certain I_{OUT} value).

4: V_{dif}={V_{IN1}^()-V_{OUT1}^(*)}

*5: A voltage equal to 98% of the output voltage whenever a stabilized V_{OUT1}=I_{OUT}{V_{OUT(T)}+1.0V} is input.

*6: V_{IN1}= the input voltage when V_{OUT1}, which appears as input voltage is gradually decreased.

*Electrical characteristics show one channel data which is measured while the other channel is stop in operation.

■ ELECTRICAL CHARACTERISTICS(Continued)

● Voltage Chart 1

PARAMETER NOMINAL OUTPUT VOLTAGE	E-0		E-1		E-2		E-3		E-4	
	OUTPUT VOLTAGE (V)		DROPOUT VOLTAGE 1 (mV) (I _{OUT} =30mA)		DROPOUT VOLTAGE 2 (mV) (I _{OUT} =100mA)		SUPPLY CURRENT (μA)		EN "H" LEVEL CURRENT (μA)	
	V _{OUT(T)}		V _{dif1}		V _{dif2}		I _{DD}		I _{ENH}	
	MIN	MAX	TYP	MAX	TYP	MAX	TYP	MAX	MIN	MAX
0.80	0.770	.0830	100	700	250	800	38.0	60.0	1.50	5.00
0.85	0.820	0.880								
0.90	0.870	0.930								
0.95	0.920	0.980								
1.00	0.970	1.030	50	500	150	600	38.5	61.5	2.00	6.50
1.05	1.020	1.080								
1.10	1.070	1.130								
1.15	1.120	1.180								
1.20	1.170	1.230	30	300	100	400	39.0	63.0	2.50	8.00
1.25	1.220	1.280								
1.30	1.270	1.330								
1.35	1.320	1.380								
1.40	1.370	1.430	27	41	90	135	39.5	64.5	3.00	9.50
1.45	1.420	1.480								
1.50	1.470	1.530								
1.55	1.519	1.581								
1.60	1.568	1.632	25	37	80	120	40.0	66.0	3.50	11.00
1.65	1.617	1.683								
1.70	1.666	1.734								
1.75	1.715	1.785								
1.80	1.764	1.836	18	28	60	90	40.0	66.0	3.50	11.00
1.85	1.813	1.887								
1.90	1.862	1.938								
1.95	1.911	1.989								
2.00	1.960	2.040	18	28	60	90	40.0	66.0	3.50	11.00
2.05	2.009	2.091								
2.10	2.058	2.142								
2.15	2.107	2.193								
2.20	2.156	2.244	18	28	60	90	40.0	66.0	3.50	11.00
2.25	2.205	2.295								
2.30	2.254	2.346								
2.35	2.303	2.397								
2.40	2.352	2.448	18	28	60	90	40.0	66.0	3.50	11.00
2.45	2.401	2.499								
2.50	2.450	2.550								
2.55	2.499	2.601								
2.60	2.548	2.652	18	28	60	90	40.0	66.0	3.50	11.00
2.65	2.597	2.703								
2.70	2.646	2.754								
2.75	2.695	2.805								
2.80	2.744	2.856	18	28	60	90	40.0	66.0	3.50	11.00
2.85	2.793	2.907								
2.90	2.842	2.958								
2.95	2.891	3.009								

ELECTRICAL CHARACTERISTICS(Continued)

● Voltage Chart 2

PARAMETER NOMINAL OUTPUT VOLTAGE	E-0		E-1		E-2		E-3		E-4	
	OUTPUT VOLTAGE (V)		DROPOUT VOLTAGE 1 (mV) (I _{out} =30mA)		DROPOUT VOLTAGE 2 (mV) (I _{out} =100mA)		SUPPLY CURRENT (μA)		EN "H" LEVEL CURRENT (μA)	
	V _{OUT(T)}	V _{OUT}		V _{dif1}		V _{dif2}		I _{DD}		I _{ENH}
MIN		MAX	TYP	MAX	TYP	MAX	TYP	MAX	MIN	MAX
3.00	2.940	3.060	15	23	50	75	40.5	67.5	4.00	12.50
3.05	2.989	3.111								
3.10	3.038	3.162								
3.15	3.087	3.213								
3.20	3.136	3.264								
3.25	3.185	3.315								
3.30	3.234	3.366								
3.35	3.283	3.417								
3.40	3.332	3.468								
3.45	3.381	3.519								
3.50	3.430	3.570								
3.55	3.479	3.621								
3.60	3.528	3.672								
3.65	3.577	3.723								
3.70	3.626	3.774								
3.75	3.675	3.825								
3.80	3.724	3.876								
3.85	3.773	3.927								
3.90	3.822	3.978								
3.95	3.871	4.029								
4.00	3.920	4.080	15	23	50	75	41.5	70.5	4.85	15.50
4.05	3.969	4.131								
4.10	4.018	4.182								
4.15	4.067	4.233								
4.20	4.116	4.284								
4.25	4.165	4.335								
4.30	4.214	4.386								
4.35	4.263	4.437								
4.40	4.312	4.488								
4.45	4.361	4.539								
4.50	4.410	4.590								
4.55	4.459	4.641								
4.60	4.508	4.692								
4.65	4.557	4.743								
4.70	4.606	4.794								
4.75	4.655	4.845								
4.80	4.704	4.896								
4.85	4.753	4.947								
4.90	4.802	4.998								
4.95	4.851	5.049								
5.00	4.900	5.100								

TEST CIRCUITS

● Circuit ①

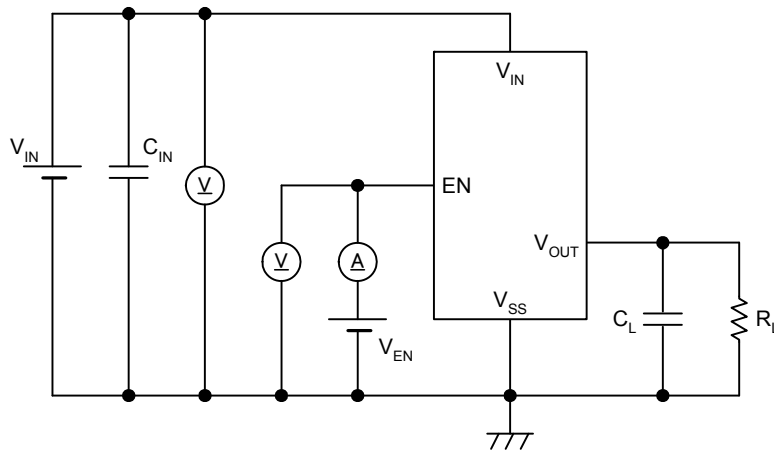

● Circuit ②

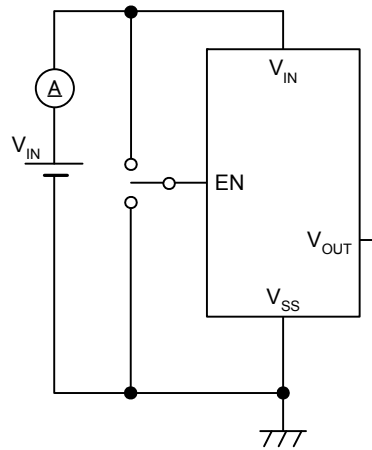

● Circuit ③

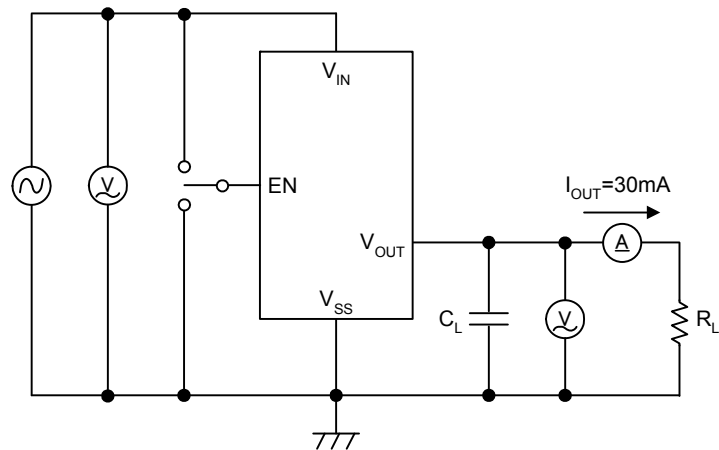

OPERATIONAL EXPLANATION

The voltage, divided by resistors R1 & R2, which are connected to the V_{ROUT} pin is compared with the internal reference voltage by the error amplifier. The P-channel MOSFET connected to the V_{ROUT} pin is then driven by the subsequent output signal. The output voltage at the V_{OUT} pin is controlled and stabilized by negative feedback. The constant current limit circuit and short circuit protection operate in relation to the level of output current.

<Low ESR Capacitor>

With the XCM406 series regulator, a stable output voltage is achievable even if low ESR capacitors are used, as a phase compensation circuit is built into the regulator. In order to ensure the effectiveness of the phase compensation, we suggest that an output capacitor (C_L) will be connected as close as possible between the output pin (V_{ROUT}) and the V_{SS} pin. Please use an output capacitor (C_L) with a capacitance based on the chart below. We also suggest an input capacitor (C_{IN}) of $1 \mu F$. This should be connected between V_{IN} and V_{SS} in order to stabilize input power source.

Output Capacitor Corresponding Table

V_{OUT}	0.8V ~ 1.45V	1.5V ~ 1.75V	1.8V ~ 5.0V
C_L	$\geq 6.8 \mu F$	$\geq 4.7 \mu F$	$\geq 1.0 \mu F$

<Current Limiter, Short-Circuit Protection>

The XCM406 series regulator offers a combination of current limit and short circuit protection by means of a built-in fixed current limiter circuit and a foldback circuit. When drops further and output current decreases. When the output pin is shorted, a current of about 50mA flows. the load current reaches the current limit level, the fixed current limiter circuit operates and output voltage drops. As a result of this drop in output voltage, the foldback circuit operates, the output voltage

<EN Pin>

The IC's internal regulator circuitry can be shut down via the signal from the EN pin with the XC6210 series. In shutdown mode, output at the V_{ROUT} pin will be pulled down to the V_{SS} level via R1 & R2. Options are available for the EN pin logic (See the product classification). Note that as the XCM406AA types are 'High Active / No Pull-Down', operations will become unstable with the EN pin open. Although the EN pin is equal to an inverter input with CMOS hysteresis, with either the pull-up or pull-down options, the CE pin input current will increase when the IC is in operation. We suggest that you use this IC with either a V_{IN} voltage or a V_{SS} voltage input at the EN pin. If this IC is used with the correct specifications for the EN pin, the IC will operate normally. However, supply current may increase as a result of through current in the IC's internal circuitry if a voltage other than V_{IN} or V_{SS} is applied.

NOTES ON USE

1. Please use this IC within the stated maximum ratings. For temporary, transitional voltage drop or voltage rising phenomenon, the IC is liable to malfunction should the ratings be exceeded.
2. Where wiring impedance is high, operations may become unstable due to noise and/or phase lag depending on output current. Please strengthen V_{IN} and V_{SS} wiring in particular.
3. Please wire the input capacitor (C_{IN}) and the output capacitor (C_L) as close to the IC as possible. When rapid input fluctuation or load fluctuation occurs, please increase the capacitor value such as C_{IN} or C_L to stabilize the operation.
4. The two dies in the same package are closely placed so that one heat generation affects the other.
Heat dissipation should be evaluated on the actual board design before finalizing. In case of light load operation like 100 μA below, but the other side is heavy load operation, the light load output voltage may happen to be elevated up to the input voltage level as a result of leakage current. As a counter measure when it happened, adding one resistor between V_{OUT} and V_{SS} pins is recommended.
5. Torex places an importance on improving our products and its reliability.
However, by any possibility, we would request user fail-safe design and post-aging treatment on system or equipment.

■ TYPICAL PERFORMANCE CHARACTERISTICS

(1) Output Voltage vs. Output Current

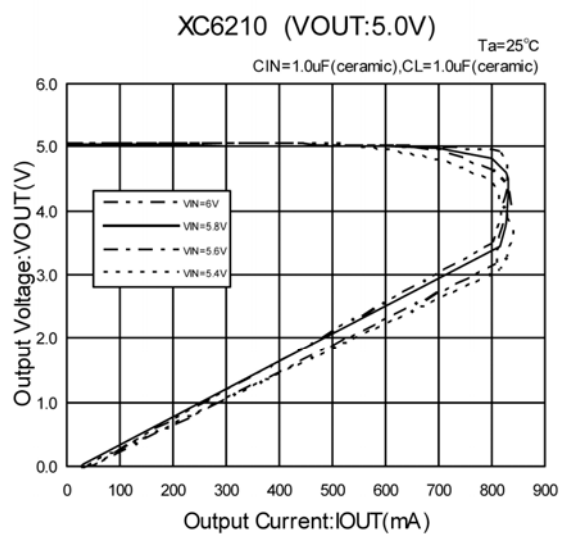
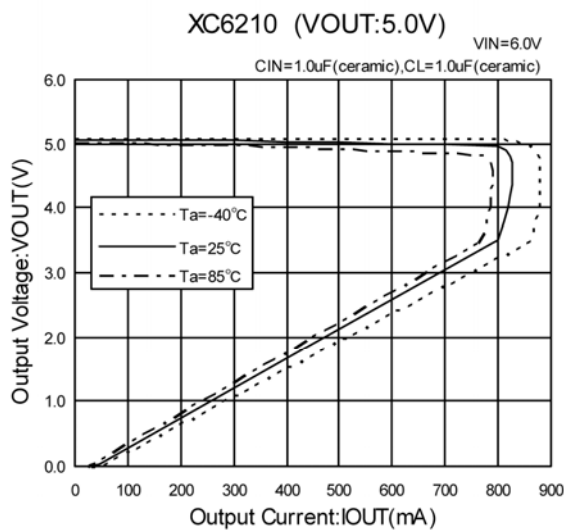
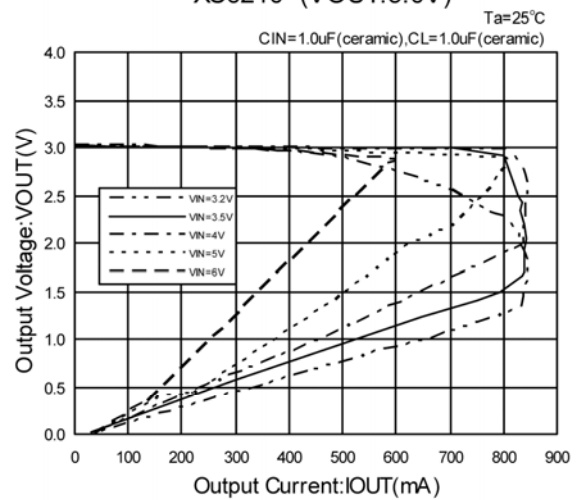
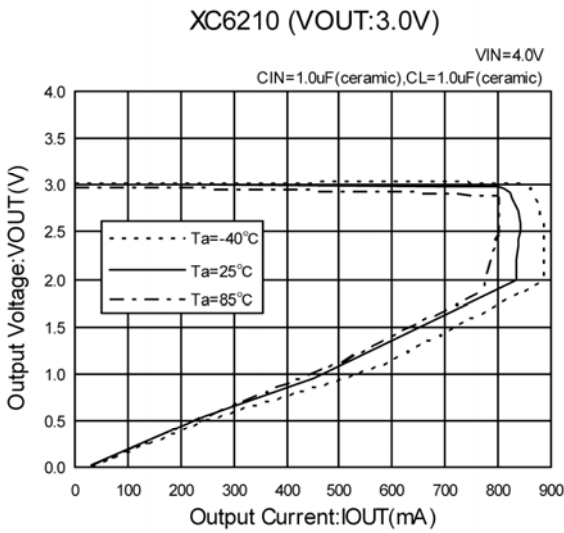
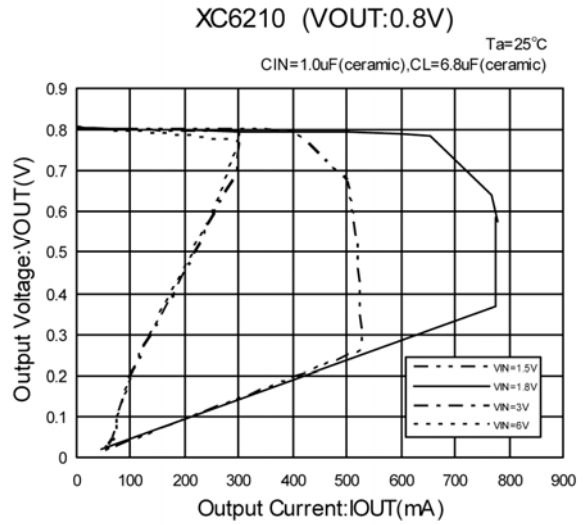
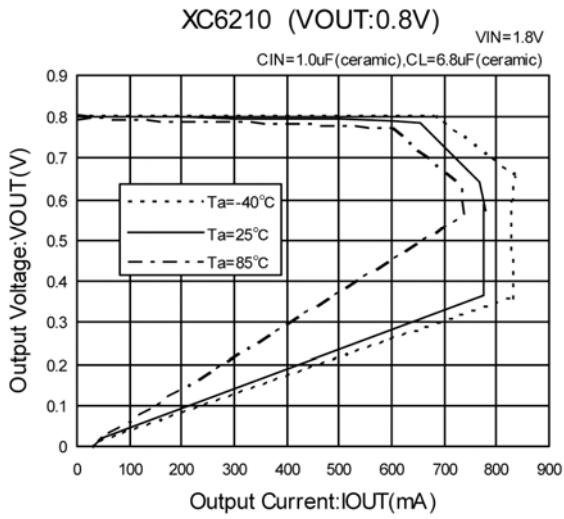

TYPICAL PERFORMANCE CHARACTERISTICS (Continued)

(2) Output Voltage vs. Input Voltage

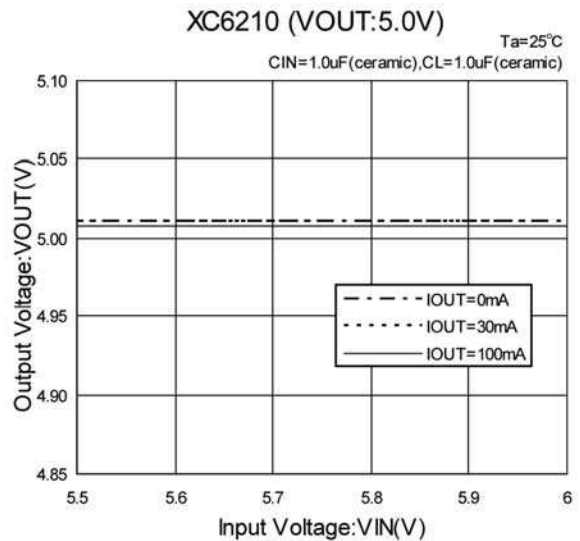
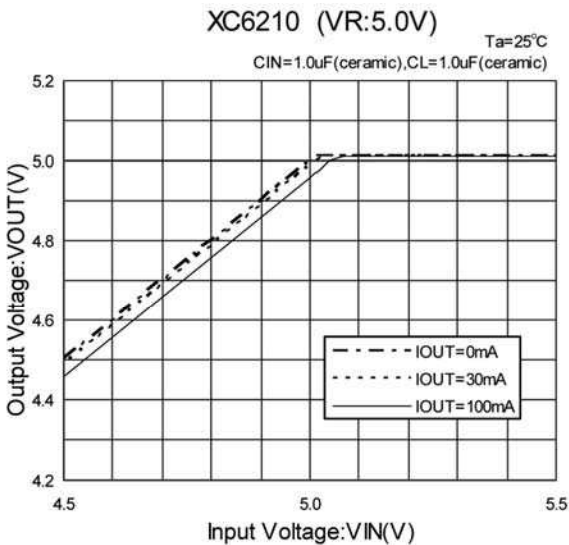
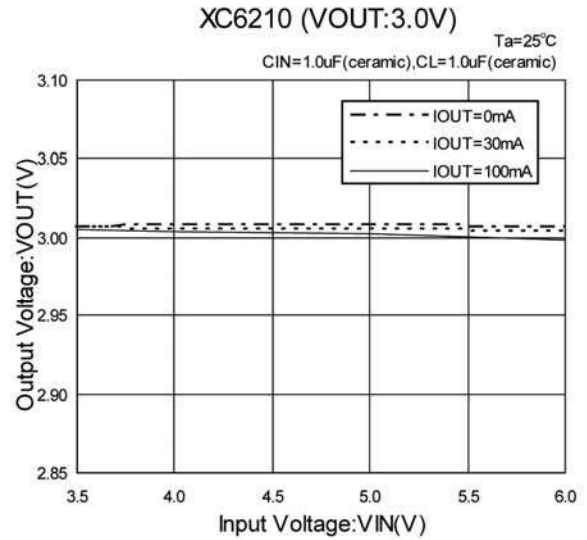
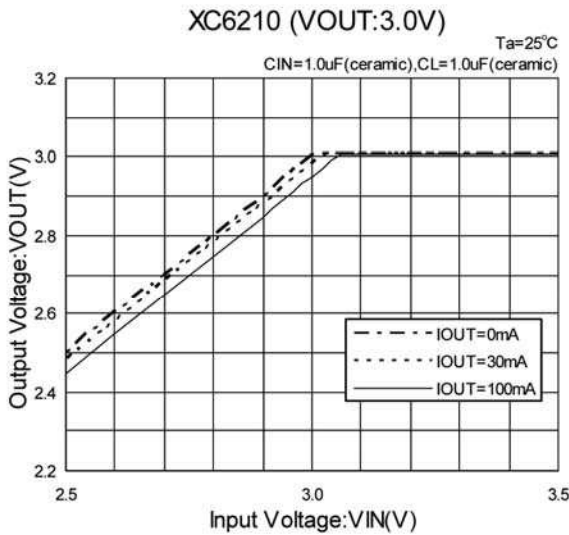
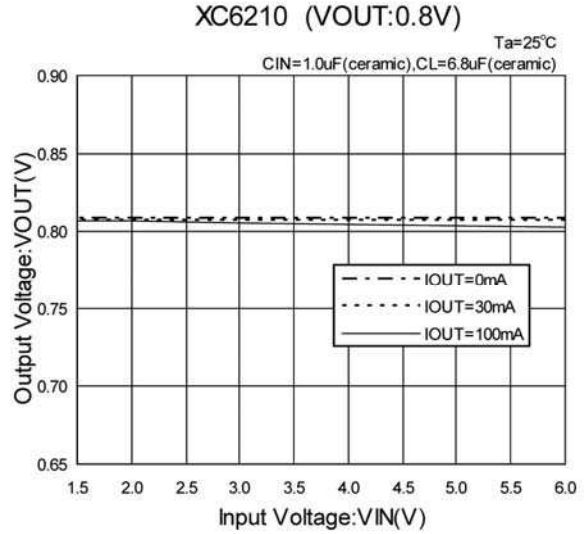
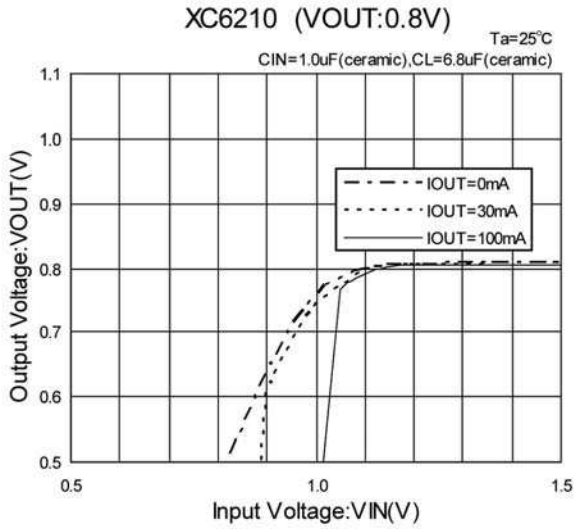

TYPICAL PERFORMANCE CHARACTERISTICS (Continued)

(3) Dropout Voltage vs. Output Current

XC6210 (VOUT:0.8V)

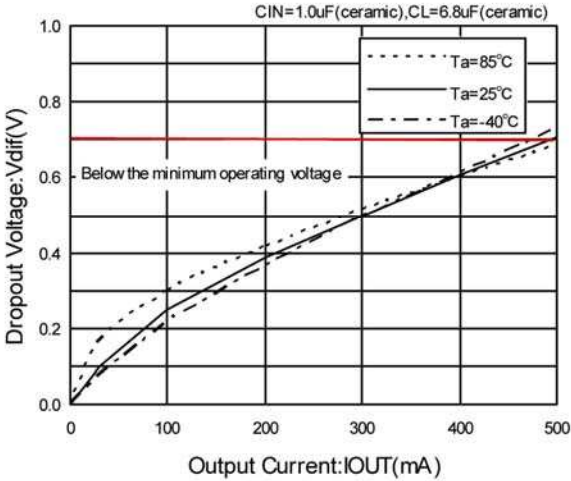

XC6210 (VOUT:1.2V)

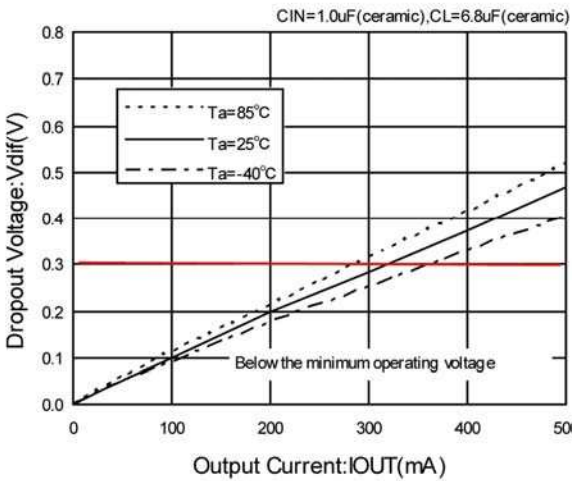

XC6210 (VOUT:1.5V)

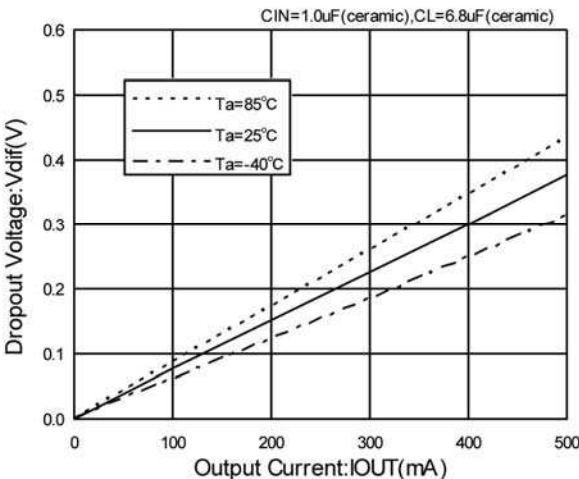

XC6210 (VOUT:2.5V)

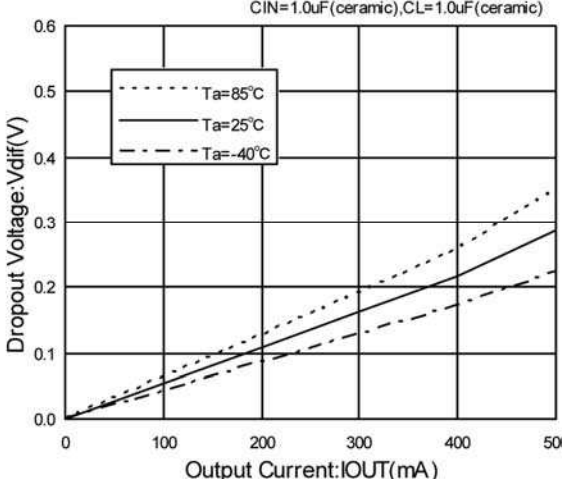

XC6210 (VOUT:3.0V)

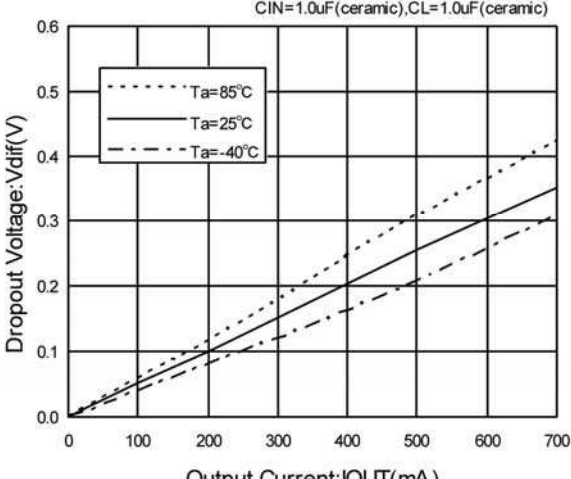

XC6210 (VOUT:5.0V)

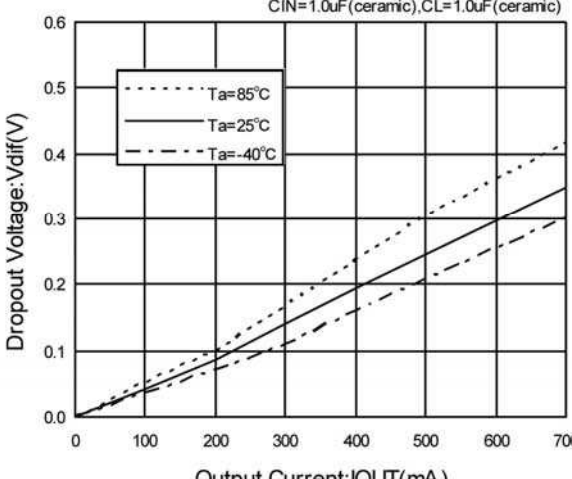

TYPICAL PERFORMANCE CHARACTERISTICS (Continued)

(4) Supply Current vs. Input Voltage

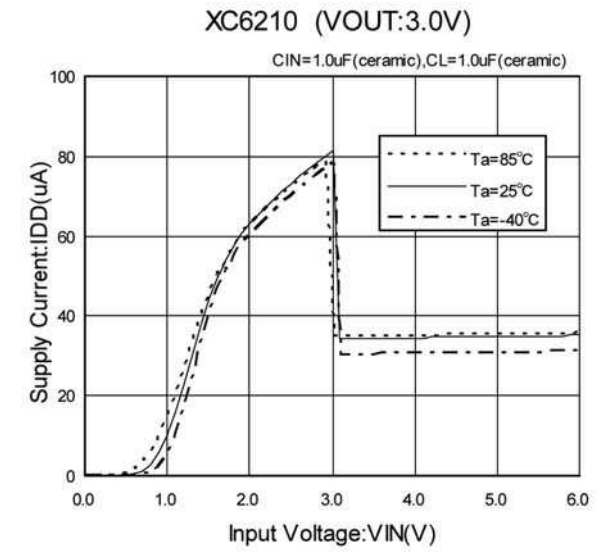
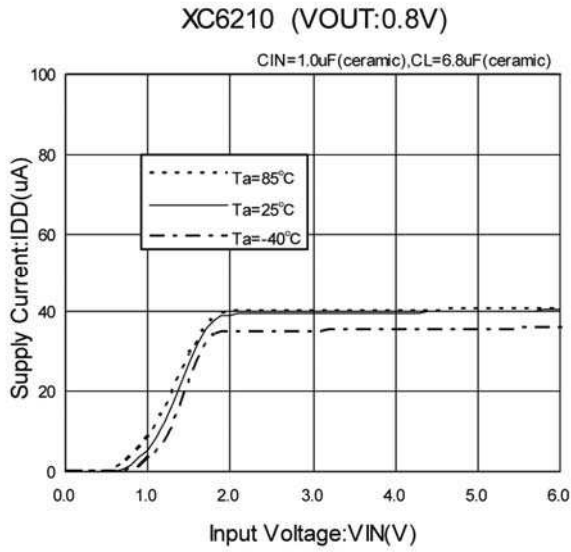

(5) Output Voltage vs. Ambient Temperature

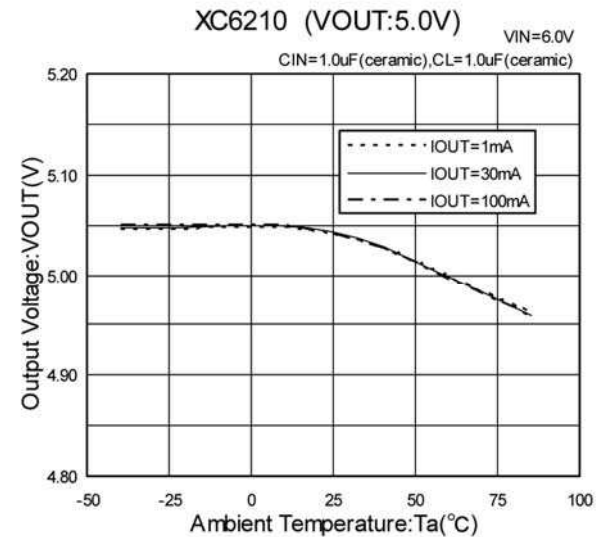
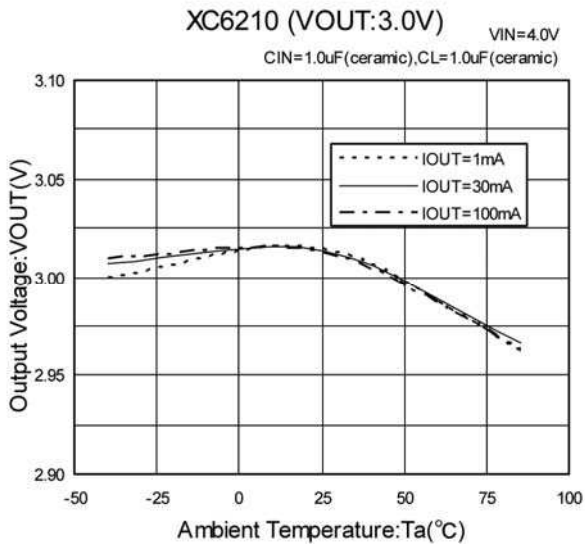
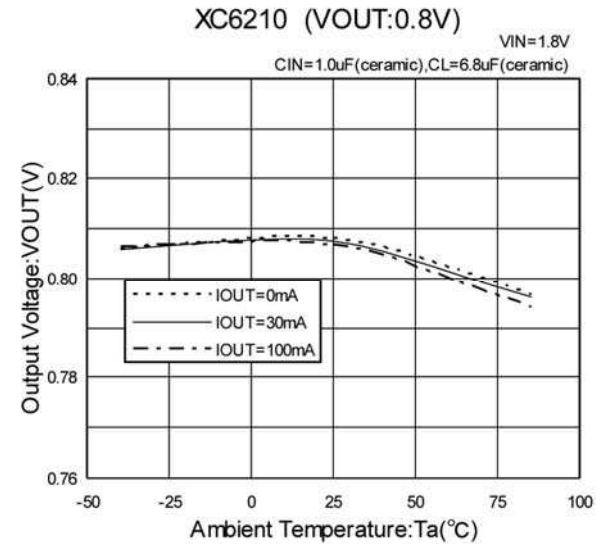
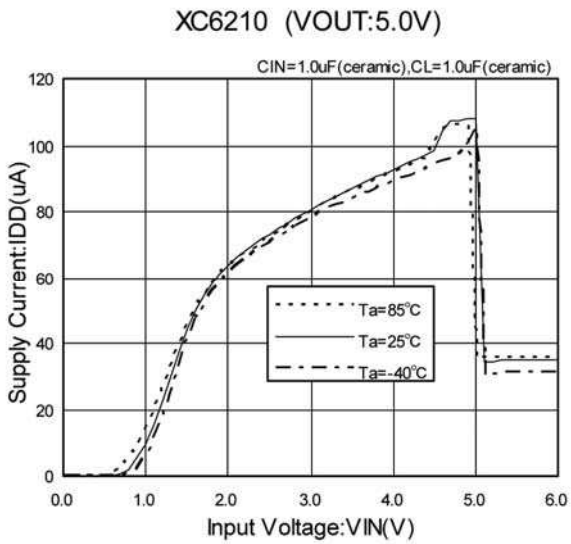

TYPICAL PERFORMANCE CHARACTERISTICS (Continued)

(6) Supply Current vs. Ambient Temperature

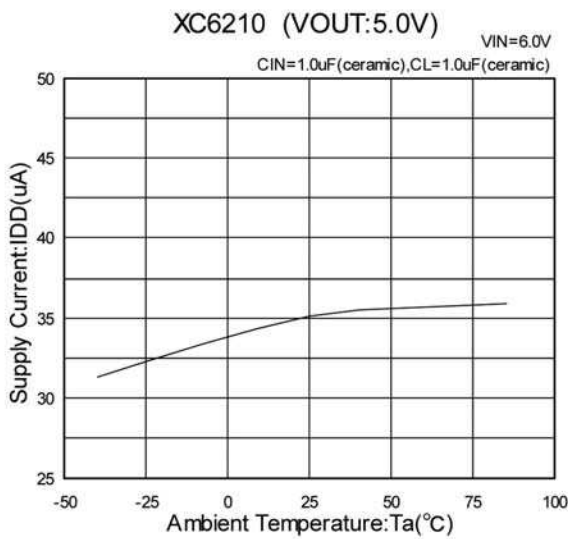
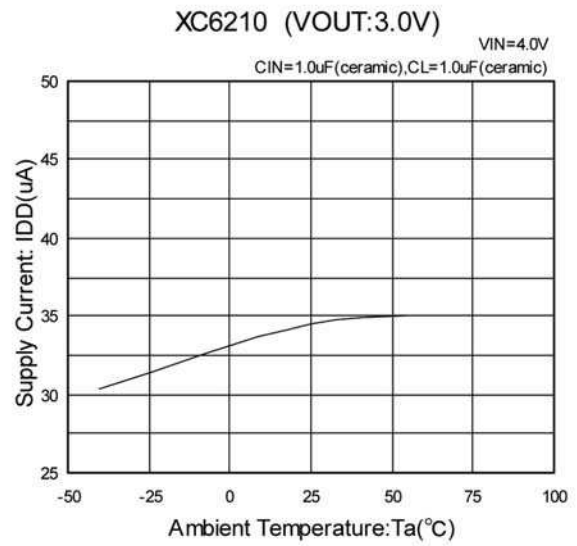
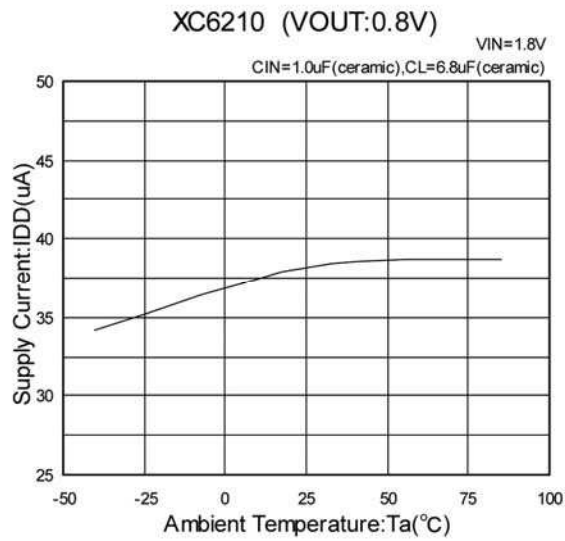

(7) CE Pin Threshold Voltage vs. Ambient Temperature

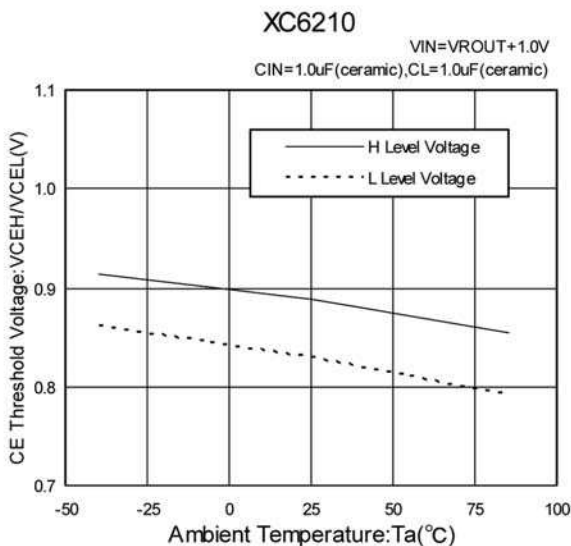

TYPICAL PERFORMANCE CHARACTERISTICS (Continued)

(8) Input Transient Response

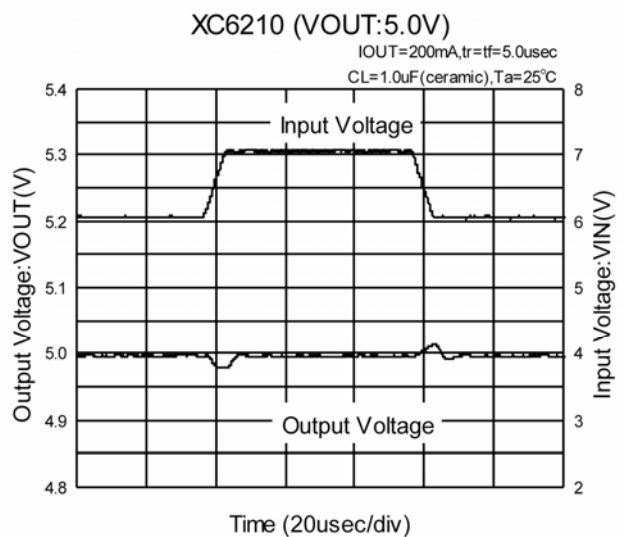
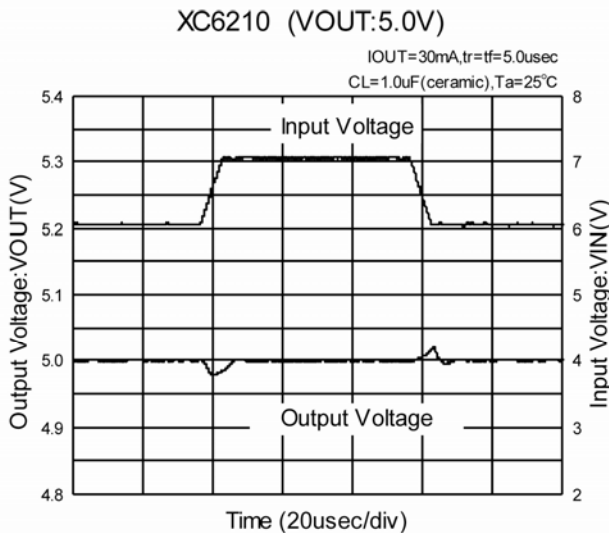
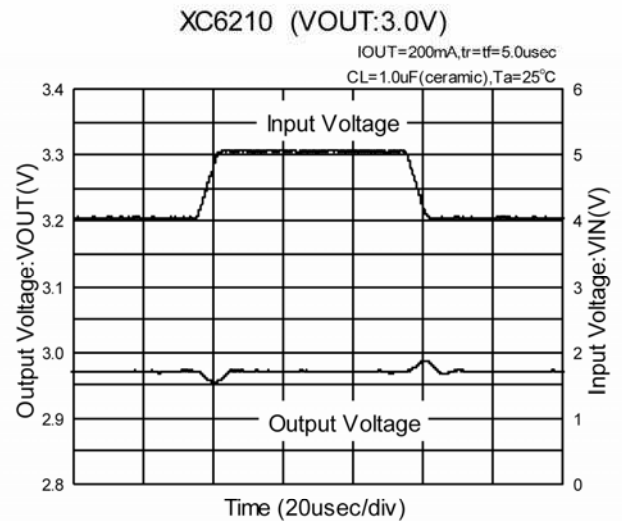
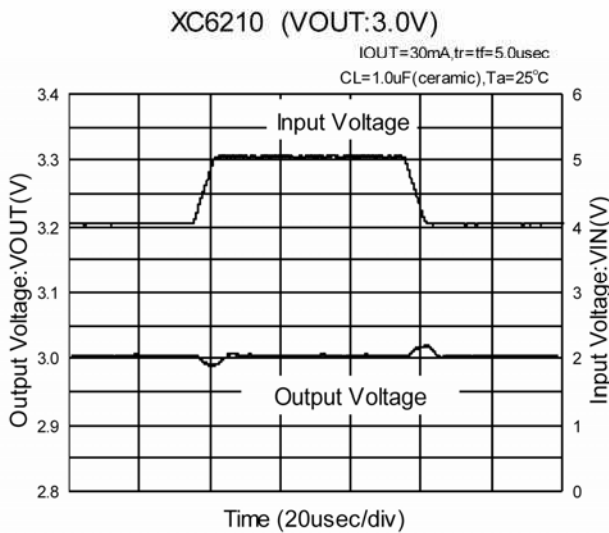
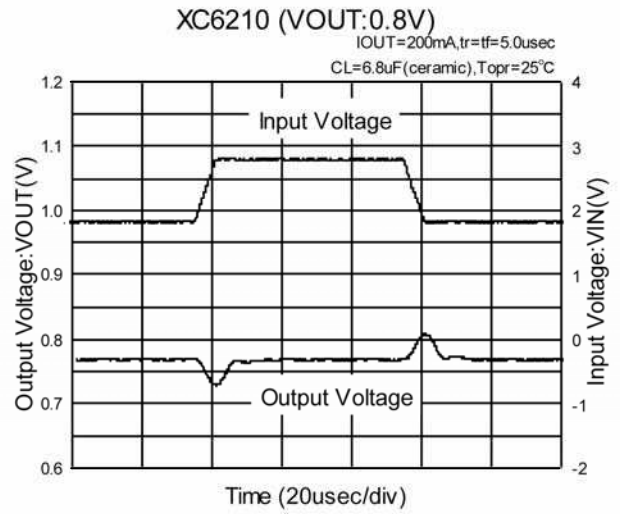
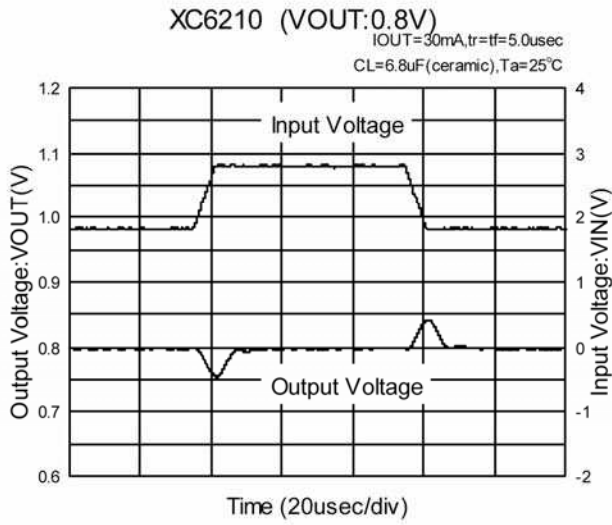

■ TYPICAL PERFORMANCE CHARACTERISTICS (Continued)

(9) Output Transient Response

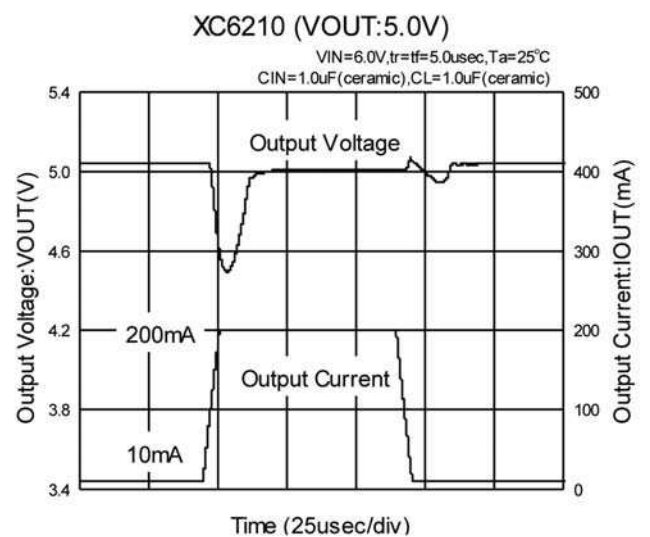
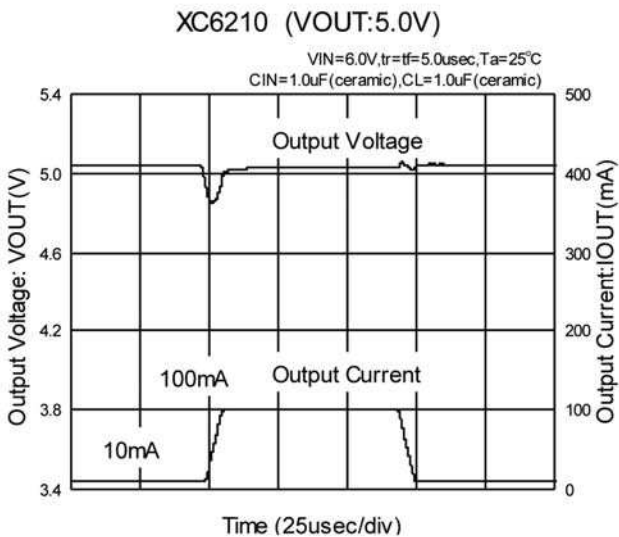
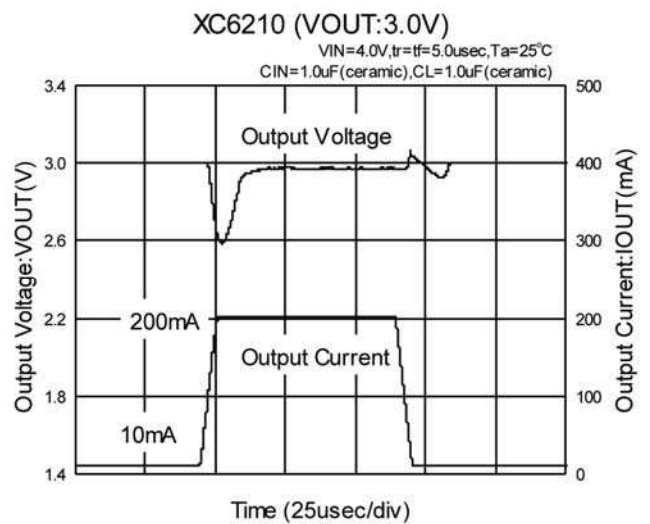
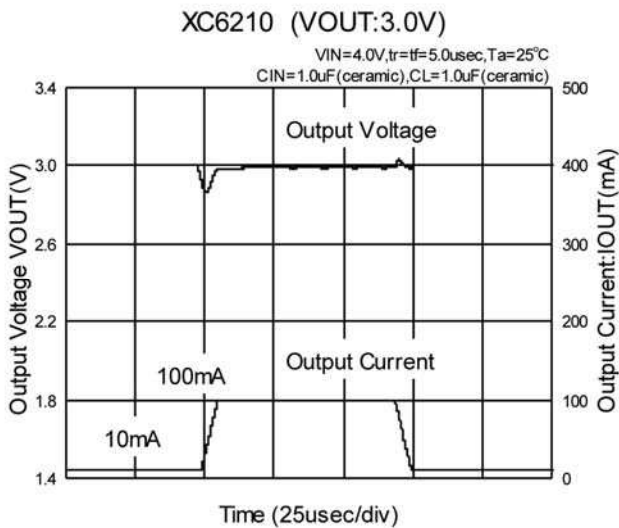
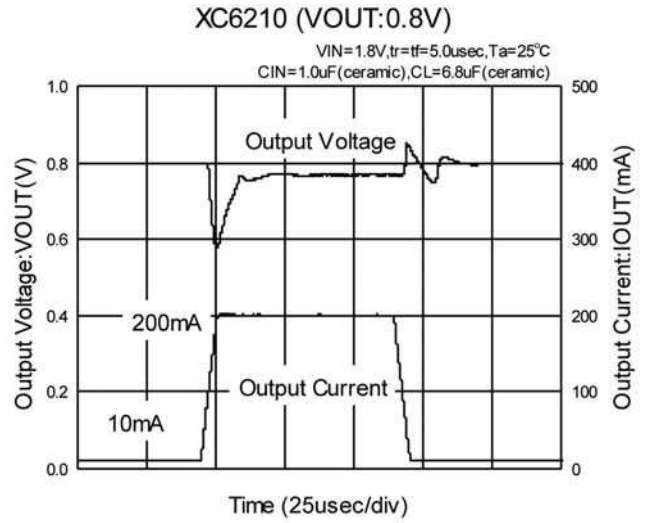
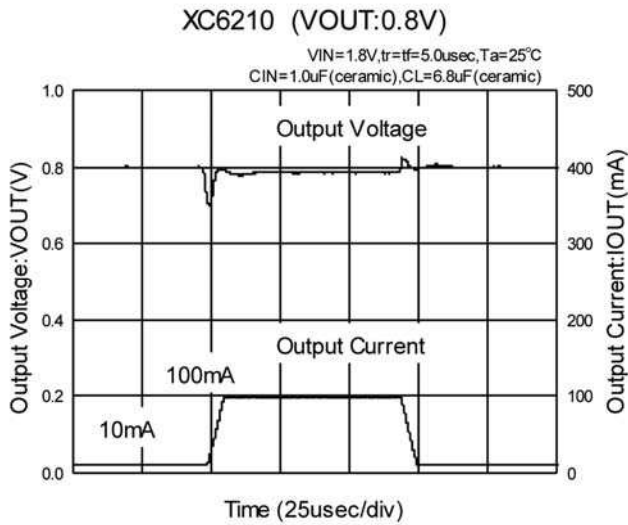

TYPICAL PERFORMANCE CHARACTERISTICS (Continued)

(10) Ripple Rejection Rate

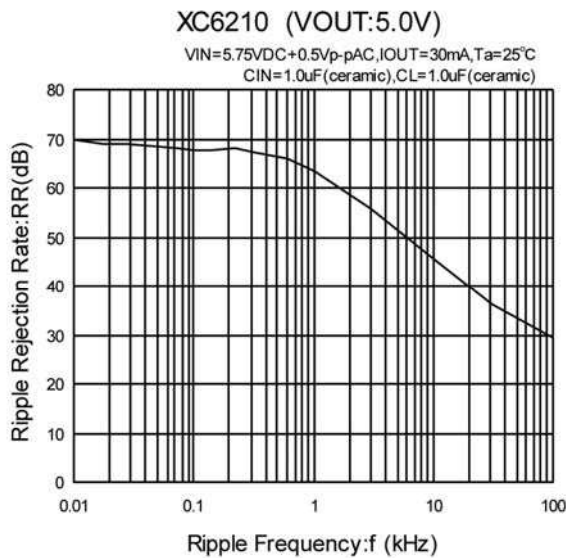
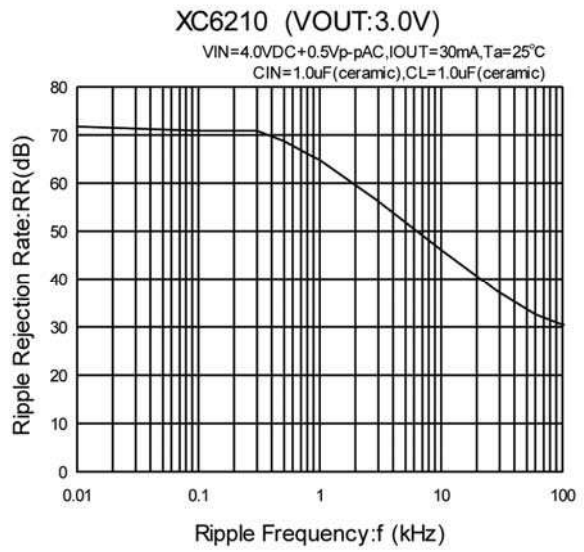
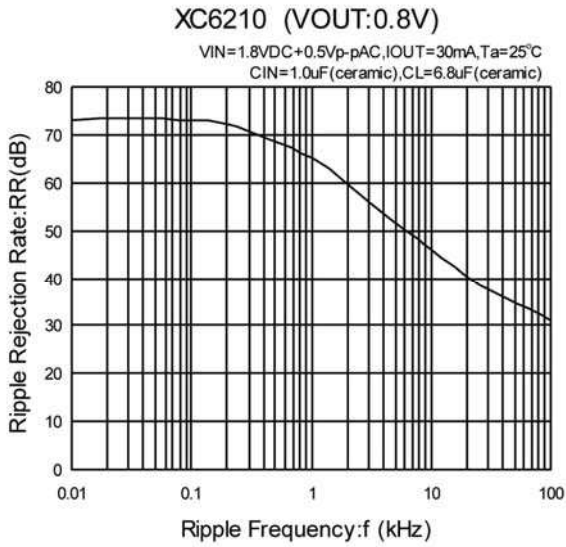

■ **TYPICAL PERFORMANCE CHARACTERISTICS (Continued)**

(11) CE Rise Time

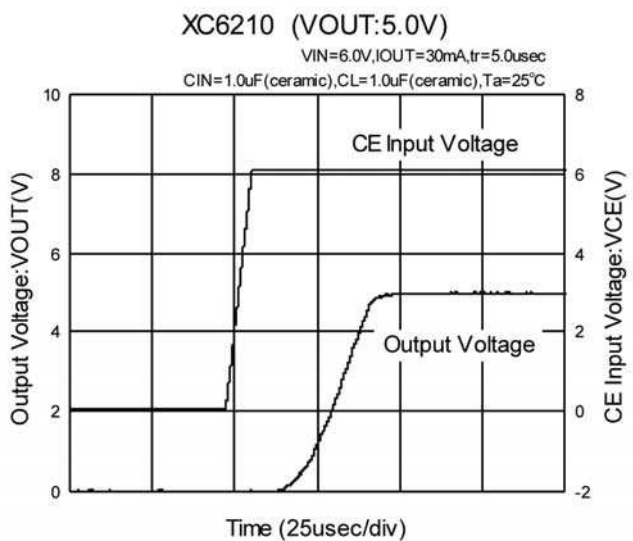
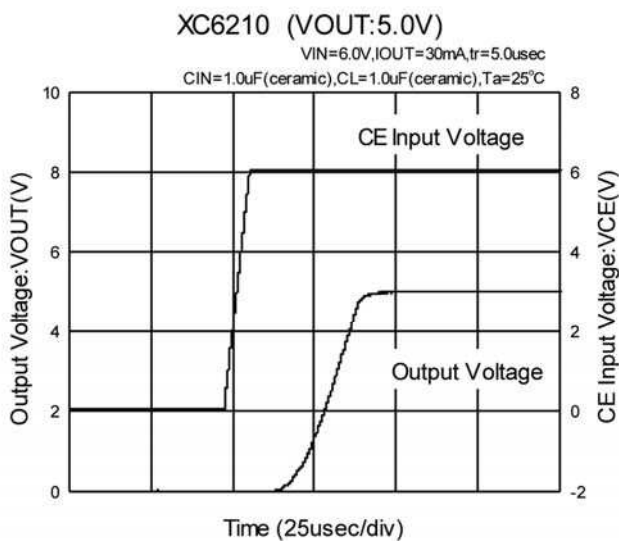
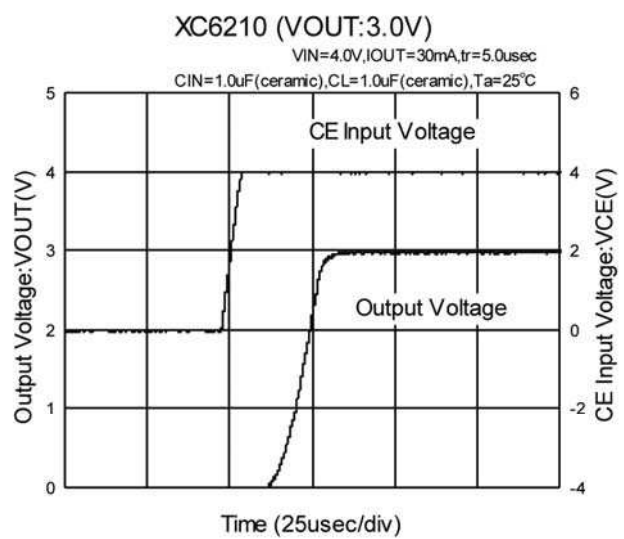
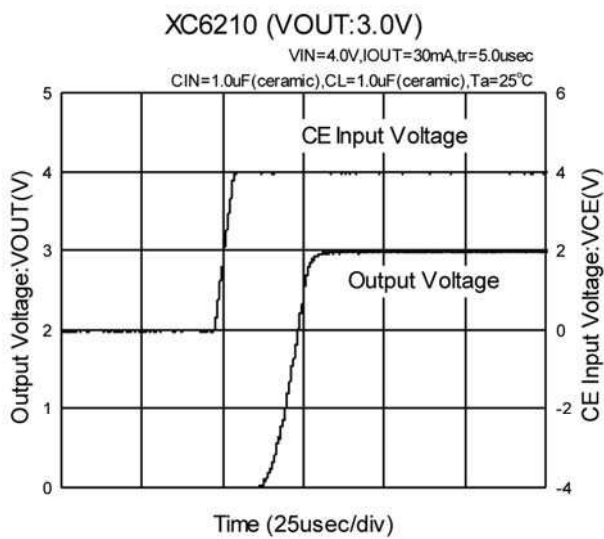
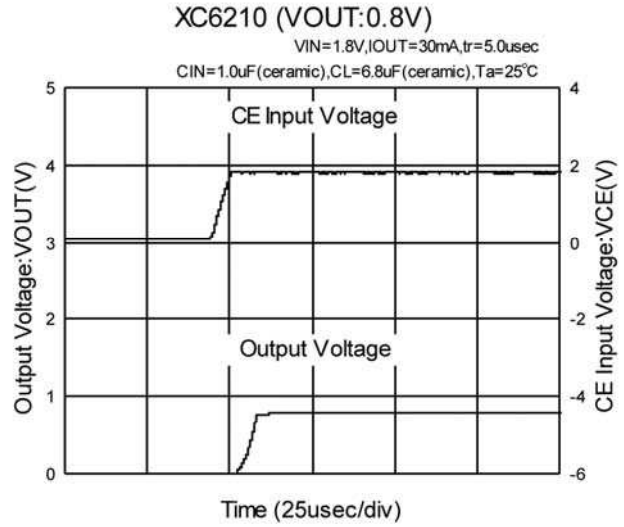
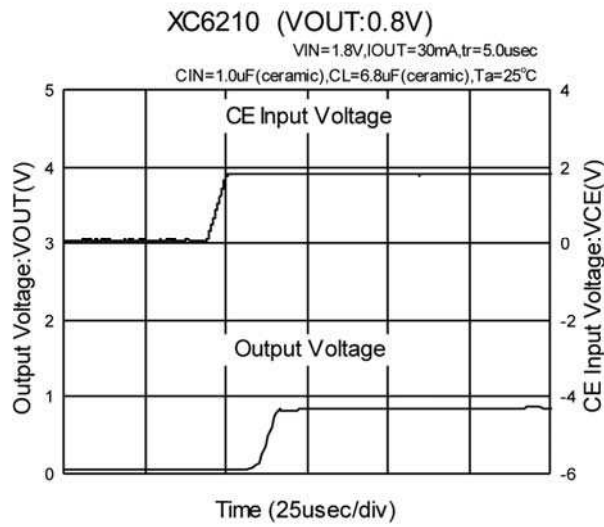

PACKAGING INFORMATION

● USP-12B01

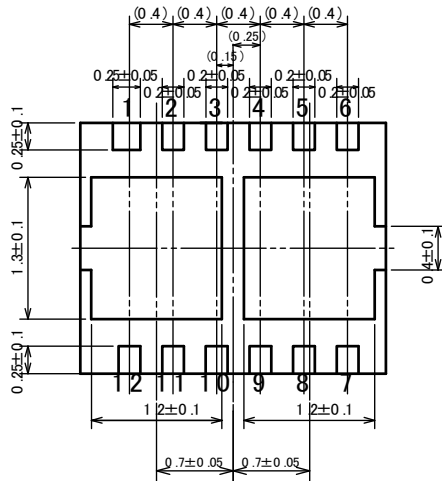
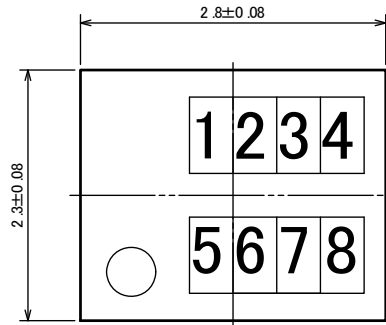

■ Lead Treatment: Au 0.3 μm Min.

*1: Soldering fillet surface is not formed because the sides of the pins are not plated.

*2: Pin No. 1 is wider than the other pins.

20/1 Unit : mm

● USP-12B01 Reference Pattern Layout

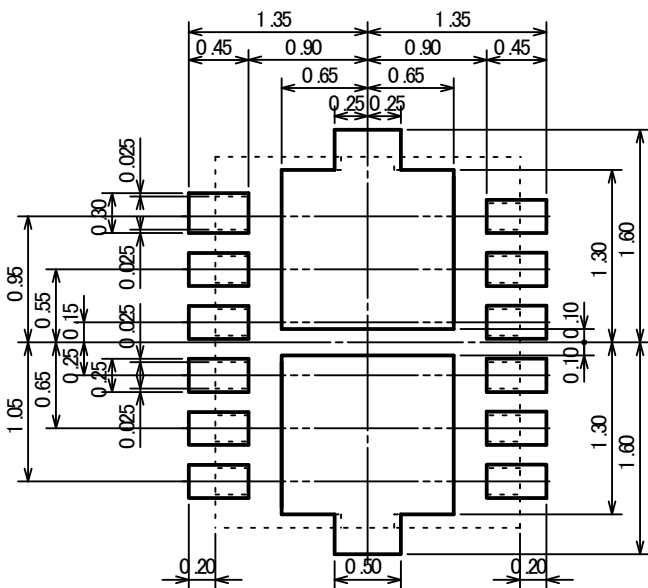

● USP-12B01 Reference Metal Mask Design

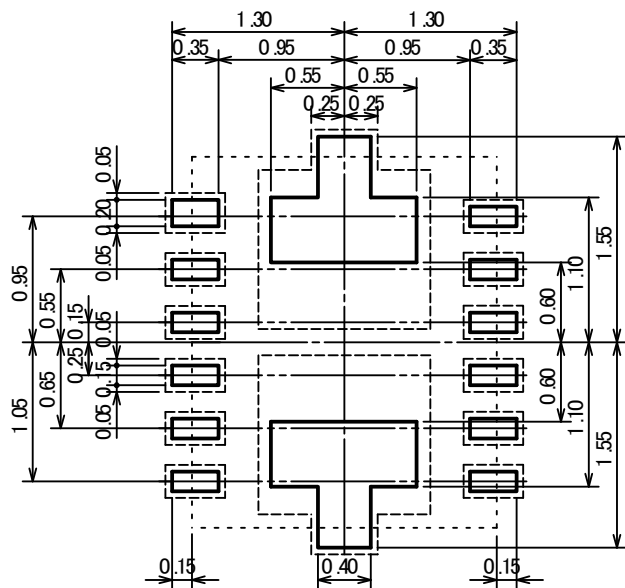

MARKING RULE

①② represents product series.

MARK		PRODUCT SERIES
①	②	
0	1	XCM406*****

③④ represents combination of IC

Ex.)

MARK		PRODUCT SERIES
③	④	
A	A	XCM406AA****
A	B	XCM406AB****

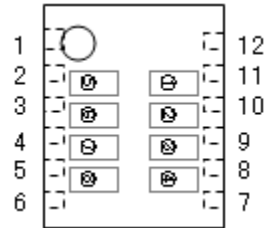

USP-12B01
(TOP VIEW)

⑤⑥ represents combination of voltage for each IC.

Ex.)

MARK		VOLTAGE (V)		PRODUCT SERIES
⑤	⑥	V _{OUT1}	V _{OUT2}	
0	1	1.3	1.5	XCM406**01**
0	2	1.8	3.3	XCM406**02**
0	3	2.5	3.3	XCM406**03**
0	4	3.3	1.5	XCM406**04**

⑦⑧ represents production lot number.

01, ..., 09, ..., 0A, ..., 0Z, 10, ..., 19, 1A, ...repeated.

(G, I, J, O, Q, W excepted)

*No character inversion used.

Ex.)

MARK		LOT NUMBER
⑦	⑧	
0	3	03
1	A	1A

1. The products and product specifications contained herein are subject to change without notice to improve performance characteristics. Consult us, or our representatives before use, to confirm that the information in this datasheet is up to date.
2. We assume no responsibility for any infringement of patents, patent rights, or other rights arising from the use of any information and circuitry in this datasheet.
3. Please ensure suitable shipping controls (including fail-safe designs and aging protection) are in force for equipment employing products listed in this datasheet.
4. The products in this datasheet are not developed, designed, or approved for use with such equipment whose failure or malfunction can be reasonably expected to directly endanger the life of, or cause significant injury to, the user.
(e.g. Atomic energy; aerospace; transport; combustion and associated safety equipment thereof.)
5. Please use the products listed in this datasheet within the specified ranges.
Should you wish to use the products under conditions exceeding the specifications, please consult us or our representatives.
6. We assume no responsibility for damage or loss due to abnormal use.
7. All rights reserved. No part of this datasheet may be copied or reproduced without the prior permission of TOREX SEMICONDUCTOR LTD.

TOREX SEMICONDUCTOR LTD.