

CMOS Logic

DESCRIPTION

XC74UL4066 is CMOS analog switch manufactured using silicon gate CMOS processes. The small supply current, which is one of the features of the CMOS logic, gives way to high speed analog or digital signal switching. As the series is integrated into a mini molded, SSOT-25 package, high density mounting is possible.

APPLICATIONS

- Palmtops
- Digital equipment

FEATURES

- High Speed Operation** : tpd = 2ns (TYP.)
- Operating Voltage Range** : 2V ~ 5.5V
- Low Power Consumption** : 1 μ A (MAX.)
- Low ON Resistance** : 22 Ω (TYP.)
- CMOS Logic Analog Switch**
- Ultra Small Package** : SSOT-25

PIN CONFIGURATION

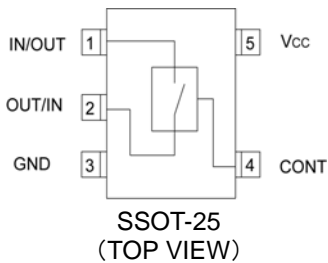

PRODUCT CLASSIFICATION

- Ordering Information

PRODUCT NAME	PACKAGE	ORDER UNIT
XC74UL4066NR	SSOT-25	3,000/Reel

LOGIC DIAGRAM

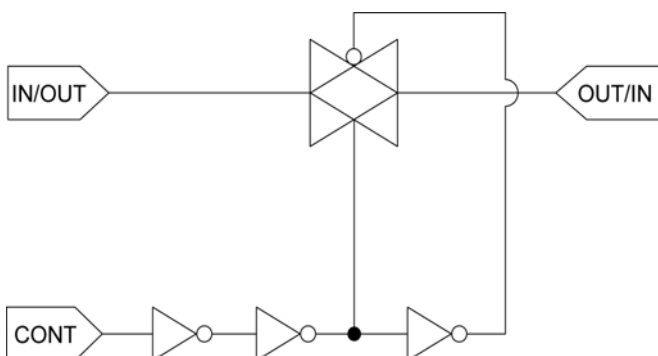

FUNCTIONS

CONTROL	STATE
L	OFF
H	ON

H=High level
L=Low level

ABSOLUTE MAXIMUM RATINGS

Ta=-40°C~85°C

PARAMETER	SYMBOL	RATINGS	UNITS
Supply Voltage	VCC	-0.5~+6.0	V
Control Input Voltage	VCONT	-0.5~+6.0	V
Switch Output Voltage	VOUT	-0.5~VCC+0.5	V
Control Input Diode Current	I _{IK}	-20	mA
Switch Output Diode Current	I _{OK}	±20	mA
Switch Output Current	I _{OUT}	±25	mA
Vcc,GND Current	I _{CC} ,I _{GND}	±50	mA
Power Dissipation *	P _d	150	mW
Storage Temperature Range	T _{stg}	-65~+150	°C

Voltage is all ground standardized.
* Ta=25°C

RECOMMENDED OPERATING CONDITIONS

PARAMETER	SYMBOL	V _{CC} (V)	CONDITIONS	UNITS
Supply Voltage	VCC	—	2~5.5	V
Input Voltage	V _{IN}	—	0~5.5	V
Output Voltage	V _{OUT}	—	0~VCC	V
Operating Temperature Range	T _{opr}	—	-40~+85	°C
Input Rise and Fall Time	tr,tf	3.3	0~100	ns/V
		5.0	0~20	

DC ELECTRICAL CHARACTERISTICS

PARAMETER	SYMBOL	V _{CC} (V)	CONDITIONS	Ta=25°C			Ta=-40°C~85°C		UNITS
				MIN.	TYP.	MAX.	MIN.	MAX.	
“High” Level Control Input Voltage”	V _{IH}	2.0		1.5	—	—	1.5	—	V
		3.0		2.1	—	—	2.1	—	
		5.5		3.85	—	—	3.85	—	
“Low” Level Control Input Voltage”	V _{IL}	2.0		—	—	0.5	—	0.5	V
		3.0		—	—	0.9	—	0.9	
		5.5		—	—	1.65	—	1.65	
Peak ON Resistance	R _{ONmax}	2.0	V _{CONT} =V _{IH}	—	130	350	—	550	Ω
		3.0	V _{IN} =0~V _{CC}	—	22	50	—	65	
		4.5	I _{IN/OUT} =1mA	—	12	25	—	35	
ON Resistance	R _{ON(1)}	2.0	V _{CONT} =V _{IH}	—	23	50	—	65	Ω
		3.0	V _{IN} =GND or V _{CC}	—	14	30	—	40	
		4.5	I _{IN/OUT} =1mA	—	10	20	—	25	
Power Off Leak Current	I _{S(OFF)}	5.5	V _{CONT} =V _{IL} , V _{IN} =V _{CC} , V _{OUT} =GND	—	—	±0.1	—	±1.0	μA
Power On Leak Current	I _{S(ON)}	5.5	V _{CONT} =V _{IH} , V _{IN} =V _{CC} , OR GND	—	—	±0.1	—	±1.0	μA
Control Input Current	I _{CONT}	5.5	V _{IN} =V _{CC} or GND	—	—	±0.1	—	±1.0	μA
Static Supply Current	I _{CC}	5.5	V _{IN} =V _{CC} or GND	—	—	1.0	—	5.0	μA

SWITCHING ELECTRICAL CHARACTERISTICS

(tr=tf=3ns)

PARAMETER	SYMBOL	V _{CC} (V)	CONDITIONS	Ta=25°C			Ta=-40°C~85°C		UNITS
				MIN.	TYP.	MAX.	MIN.	MAX.	
Delay Time	t _{PLH}	2.0	R _L =10kΩ	—	4	20	—	23	ns
	t _{PHL}	3.3	C _L =50pF	—	3	6	—	8	
		5.0		—	2	5	—	6	
Output Enable Time	t _{ZL}	2.0	R _L =1kΩ	—	9	50	—	65	ns
	t _{ZH}	3.3	C _L =50pF	—	5	10	—	12	
		5.0		—	3	8	—	10	
Output Disable Time	t _{LZ}	2.0	R _L =1kΩ	—	12	60	—	75	ns
	t _{HZ}	3.3	C _L =50pF	—	10	23	—	27	
		5.0		—	8	20	—	25	
Sine Wave Distortion Rate		3.0	R _L =10kΩ C _L =50pF f _{IN} =1kHz	—	0.05	—	—	—	%
-3dB Band Width		3.0	R _L =600kΩ, C _L =50pF $20 \log_{10} \frac{V_{OUT}}{V_{IN}} = -3dB$	—	200	—	—	—	MHz
Feed Through (Switch- off)		3.0	R _L =600kΩ C _L =50pF f _{IN} =1kHz	—	-60	—	—	—	dB
Cross Talk (Control Switch)		2.0	R _L =600kΩ	—	60	—	—	—	mV
		3.0	C _L =50pF	—	100	—	—	—	
		4.5	f _{IN} =1kHz	—	150	—	—	—	
Maximum Control Input Frequency		2.0	R _L =1kΩ	—	30	—	—	—	MHz
		3.0	C _L =15pF	—	30	—	—	—	
		4.5	V _{OUT} =V _{CC} /2	—	30	—	—	—	
Control Input Capacitance	C _{iN}	—		—	5	10	—	10	pF
Switch Input/Output Capacitance	C _{iN/OUT}	—		—	6	—	—	—	pF
Feed Through Capacitance	C _{iN-OUT}	—		—	0.5	—	—	—	pF
Power Dissipation Capacitance	C _{PD}	—		—	13	—	—	—	pF

Note: CPD is defined as the value of the internal equivalent capacitance which is derived from the operating supply current at times of "No Load".

Ensure that the average operating supply current at times of "No Load" meets the following conditions:

$$I_{CC} (opr) = C_{PD} \cdot V_{CC} \cdot f_{IN} + I_{CC}$$

XC74UL4066

■ DELAY TIME

● WAVEFORM

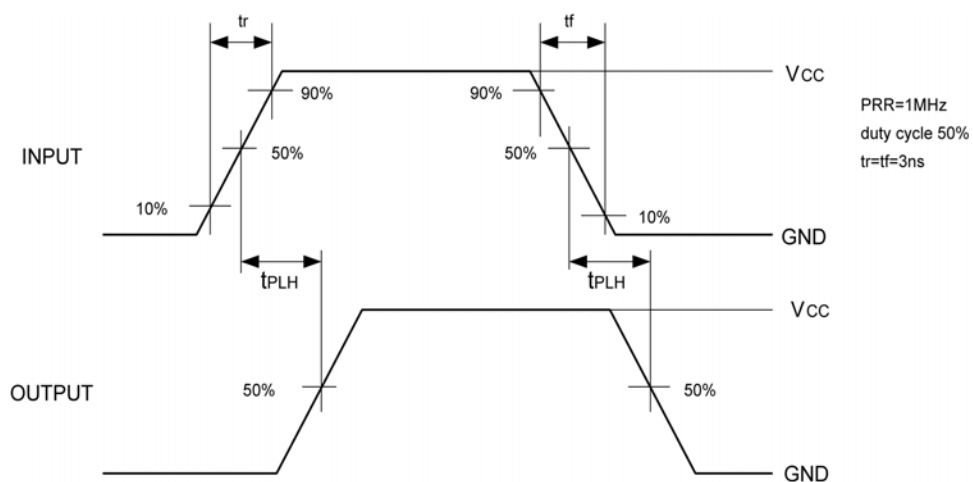

● TEST CIRCUIT

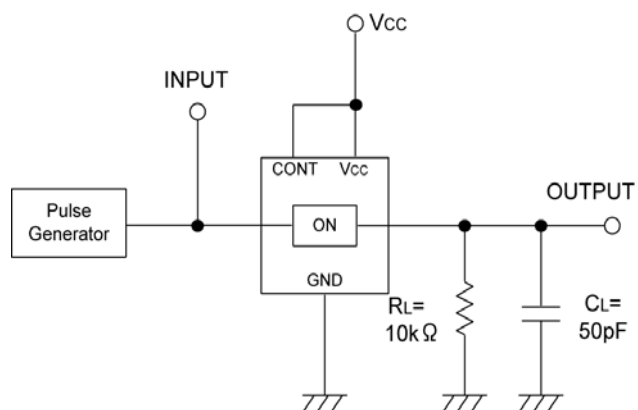

Note: Open output when measuring supply current

■ OUTPUT ENABLE TIME, OUTPUT DISABLE TIME

● WAVEFORM

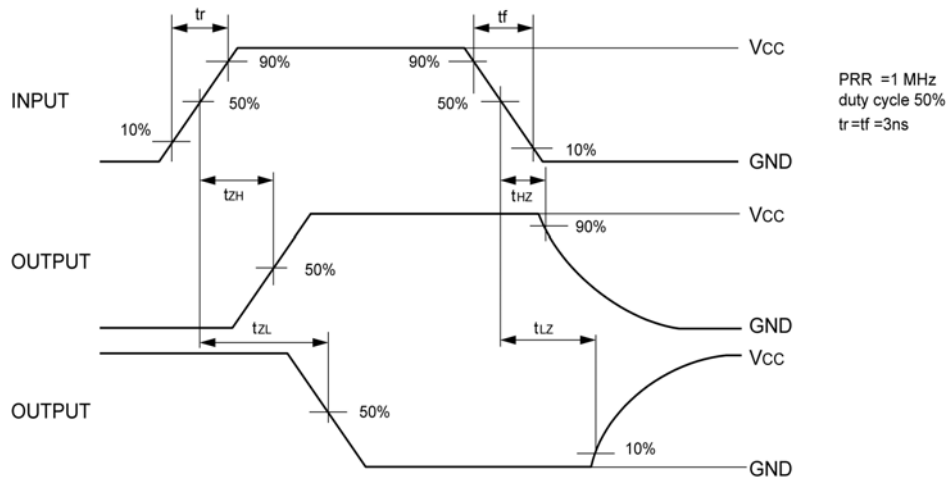

● TEST CIRCUIT

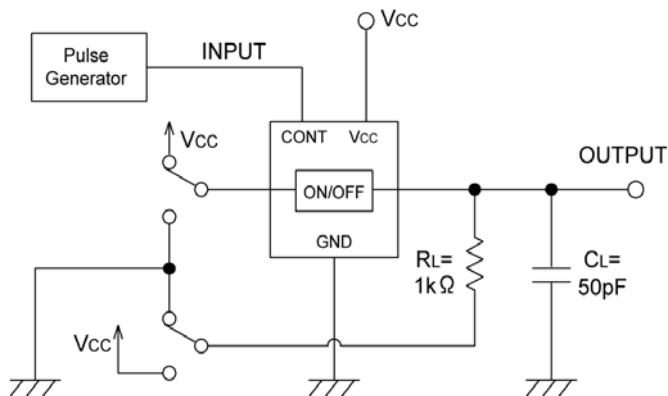

■ SINE WAVE DISTORTION RATE

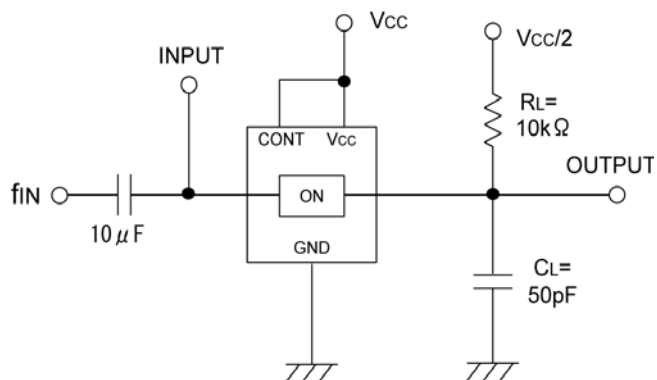

* Input by sine wave

■ -3dB BAND WIDTH

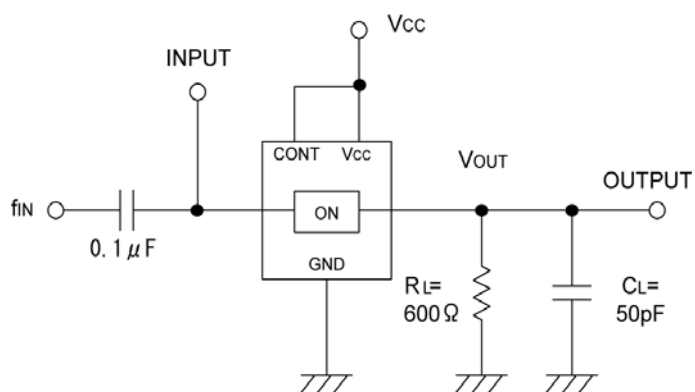

* Input by sine wave

■ FEED THROUGH TEST CIRCUIT

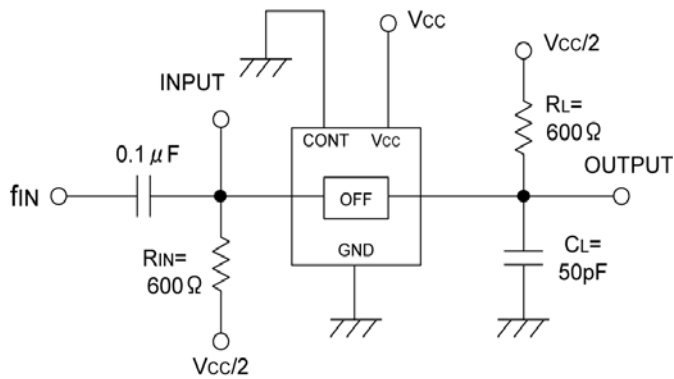

* Input by sine wave

■ CROSS TALK

● WAVEFORM

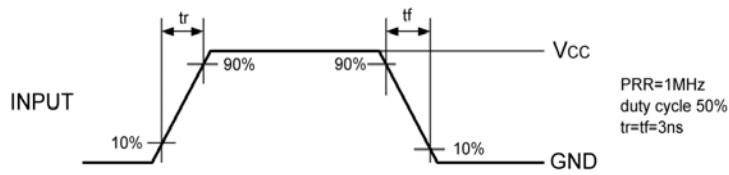

● TEST CIRCUIT

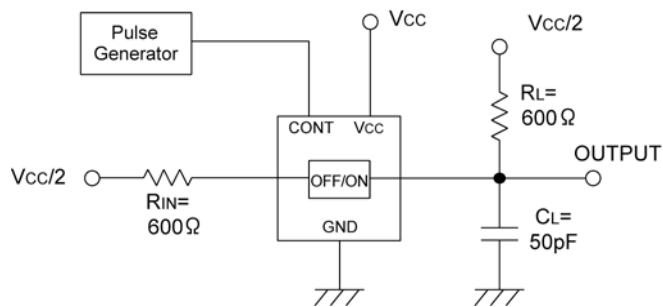

■ MAXIMUM CONTROL INPUT FREQUENCY

● WAVEFORM

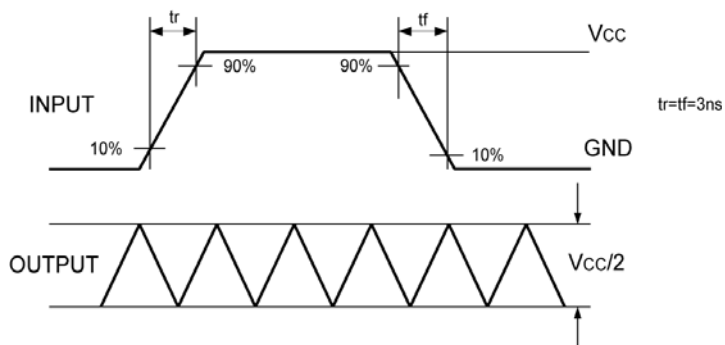

● TEST CIRCUIT

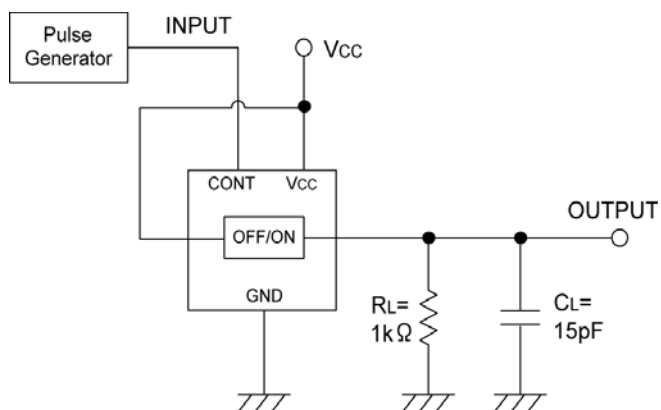

■ ON RESISTANCE

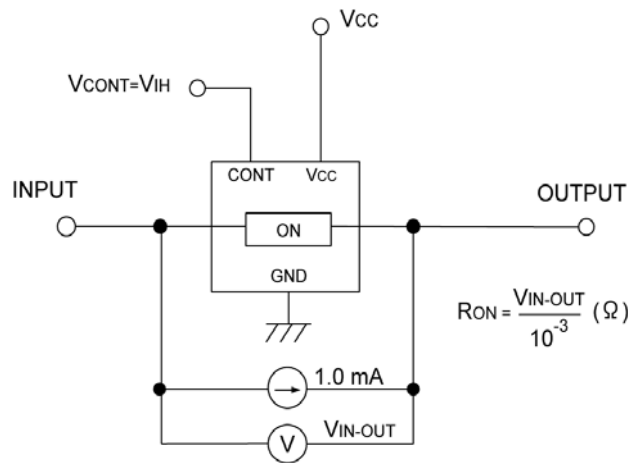

■ VOLTAGE DEPENDANCIES OF ON RESISTANCE

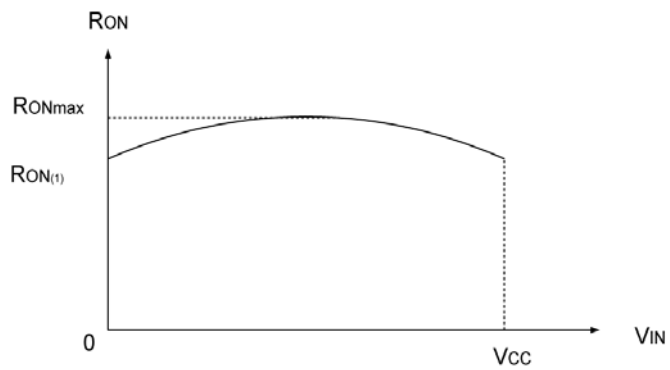

■ POWER OFF LEAK CURRENT

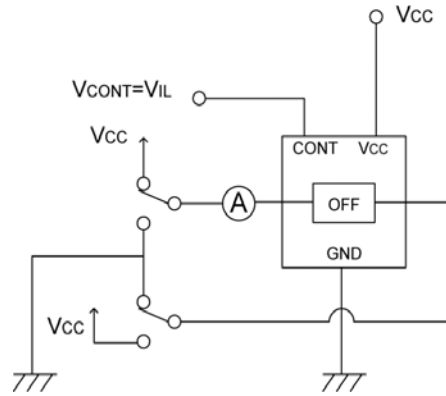

■ POWER ON LEAK CURRENT

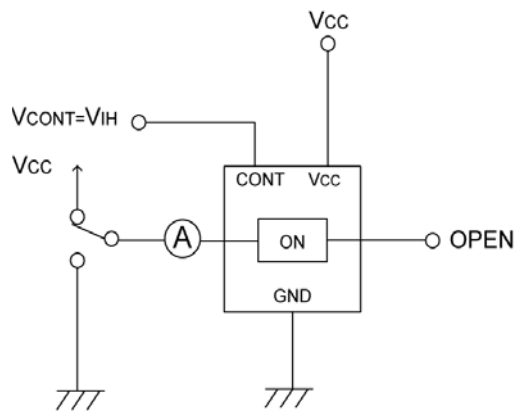

1. The products and product specifications contained herein are subject to change without notice to improve performance characteristics. Consult us, or our representatives before use, to confirm that the information in this catalog is up to date.
2. We assume no responsibility for any infringement of patents, patent rights, or other rights arising from the use of any information and circuitry in this catalog.
3. Please ensure suitable shipping controls (including fail-safe designs and aging protection) are in force for equipment employing products listed in this catalog.
4. The products in this catalog are not developed, designed, or approved for use with such equipment whose failure of malfunction can be reasonably expected to directly endanger the life of, or cause significant injury to, the user.
(e.g. Atomic energy; aerospace; transport; combustion and associated safety equipment thereof.)
5. Please use the products listed in this catalog within the specified ranges.
Should you wish to use the products under conditions exceeding the specifications, please consult us or our representatives.
6. We assume no responsibility for damage or loss due to abnormal use.
7. All rights reserved. No part of this catalog may be copied or reproduced without the prior permission of Torex Semiconductor Ltd.

TOREX SEMICONDUCTOR LTD.