

XC74UL02AA

ETR1303_002

CMOS Logic

■ GENERAL DESCRIPTION

The XC74UL02AA is a 2-input CMOS NOR Gate, manufactured using silicon gate CMOS fabrication.

CMOS low power circuit operation makes high speed LS-TTL operation achievable.

With a wave forming buffer connected internally, stabilized output can be achieved as the circuit offers high noise immunity.

As the XC74UL02AA is integrated into mini molded, SSOT-25 and SON-6 package, high density mounting is possible.

■ APPLICATIONS

- Palmtops
- Digital equipment

■ FEATURES

High Speed Operation : tpd = 2.65ns (TYP.)

Operating Voltage Range : 2V ~ 5.5V

Low Power Consumption : 1 μ A (MAX.)

CMOS 2-Input NOR Gate

Ultra Small Packages : SSOT-25, SON-6*

* Under Development

■ PIN CONFIGURATION

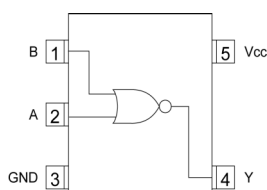

SSOT-25
(TOP VIEW)
XC74UL02AAN

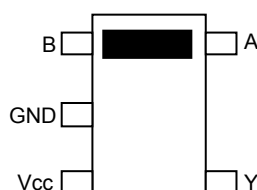

SON-6
(TOP VIEW)
XC74UL02AAR

■ FUNCTIONS

INPUT		OUTPUT
A	B	Y
L	L	H
L	H	L
H	L	L
H	H	L

H=High level

L=Low level

■ ABSOLUTE MAXIMUM RATINGS

Ta=-40°C~85°C

PARAMETER	SYMBOL	RATINGS	UNITS
Supply Voltage	Vcc	-0.5~+6.0	V
Input Voltage	VIN	-0.5~+6.0	V
Output Voltage	VOUT	-0.5~Vcc+0.5	V
Input Diode Current	I _{IK}	-20	mA
Output Diode Current	I _{OK}	±20	mA
Output Current	I _{OUT}	±25	mA
Vcc,GND Current	I _{CC} ,I _{GND}	±50	mA
Power Dissipation	SSOT-25* ¹	Pd	150
	SON-6* ²		200
Storage Temperature Range	T _{stg}	-65~+150	°C

Voltage is all ground standardized.

* 1) Ta=55°C

* 2) Ta=25°C

RECOMMENDED OPERATING CONDITIONS

PARAMETER	SYMBOL	V _{CC} (V)	CONDITIONS	UNITS
Supply Voltage	V _{CC}	—	2~5.5	V
Input Voltage	V _{IN}	—	0~5.5	V
Output Voltage	V _{OUT}	—	0~V _{CC}	V
Operating Temperature Range	T _{opr}	—	-40~+85	°C
Output Current	I _{OH}	3.0	-4	mA
		4.5	-8	
	I _{OL}	3.0	4	
		4.5	8	
Input Rise and Fall Time	t _{r,tf}	3.3	0~100	ns
		5.0	0~20	

DC ELECTRICAL CHARACTERISTICS

PARAMETER	SYMBOL	V _{CC} (V)	CONDITIONS	Ta=25°C			Ta=-40°C~85°C		UNITS	
				MIN.	TYP.	MAX.	MIN.	MAX.		
Input Voltage	V _{IH}	2.0		1.5	—	—	1.5	—	V	
		3.0		2.1	—	—	2.1	—		
		5.5		3.85	—	—	3.85	—		
	V _{IL}	2.0		—	—	0.5	—	0.5	V	
		3.0		—	—	0.9	—	0.9		
		5.5		—	—	1.65	—	1.65		
Output Voltage	V _{OH}	2.0	V _{IN} =V _{IH}	I _{OH} =-50 μA	1.9	2.0	—	1.9	—	V
		3.0			2.9	3.0	—	2.9	—	
		4.5		4.4	4.5	—	4.4	—		
		3.0		I _{OH} =-4mA	2.58	—	—	2.48	—	
		4.5			I _{OH} =-8mA	3.94	—	—	3.80	
	V _{OL}	2.0	V _{IN} =V _{IH}	I _{OL} =50 μA		—	—	0.1	—	0.1
		3.0			—	—	0.1	—	0.1	
		4.5			—	—	0.1	—	0.1	
		3.0		I _{OL} =4mA	—	—	0.36	—	0.44	
		4.5			I _{OL} =8mA	—	—	0.36	—	0.44
Input Current	I _{IN}	0~5.5	V _{IN} =V _{CC} or GND	-0.1		—	0.1	-1.0	1.0	μA
Static Supply Current	I _{CC}	5.5	V _{IN} =V _{CC} or GND, I _{OUT} =0 μA	—	—	1.0	—	10.0		

SWITCHING ELECTRICAL CHARACTERISTICS

t_r=t_f=3ns

PARAMETER	SYMBOL	C _L	V _{CC} (V)	CONDITIONS	Ta=25°C			Ta=-40°C~85°C		UNITS
					MIN.	TYP.	MAX.	MIN.	MAX.	
Delay Time	t _{PLH}	15pF	3.3		—	3.9	7.9	1.0	9.5	ns
			5.0		—	2.7	5.5	1.0	6.5	
		50pF	3.3		—	5.5	11.4	1.0	13.0	ns
			5.0		—	3.9	7.5	1.0	8.5	
	t _{PHL}	15pF	3.3		—	3.5	7.9	1.0	9.5	ns
			5.0		—	2.6	5.5	1.0	6.5	
		50pF	3.3		—	4.9	11.4	1.0	13.0	ns
			5.0		—	3.6	7.5	1.0	8.5	
Input Capacitance	C _{IN}	—	5.0	V _{IN} =V _{CC} or GND	—	4	10	—	10	pF
Power Dissipation Capacitance	C _{pd}	No Load, f=1MHz			—	9.7	—	—	—	pF

■ WAVEFORM

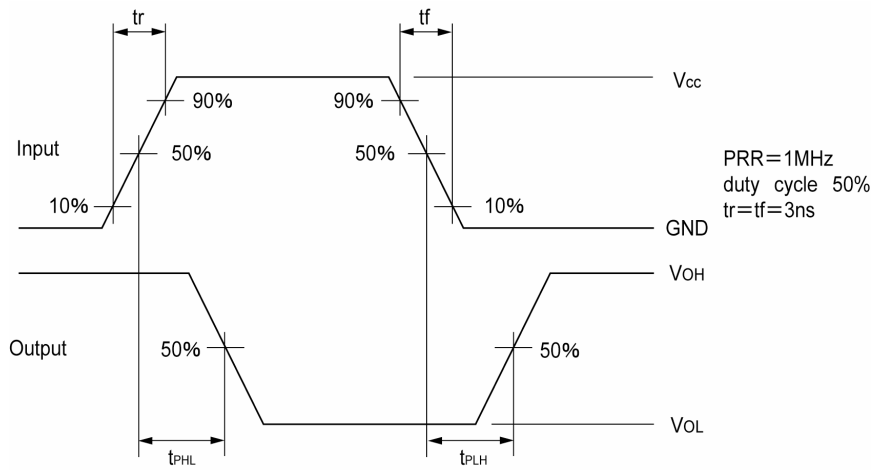

■ TEST CIRCUIT

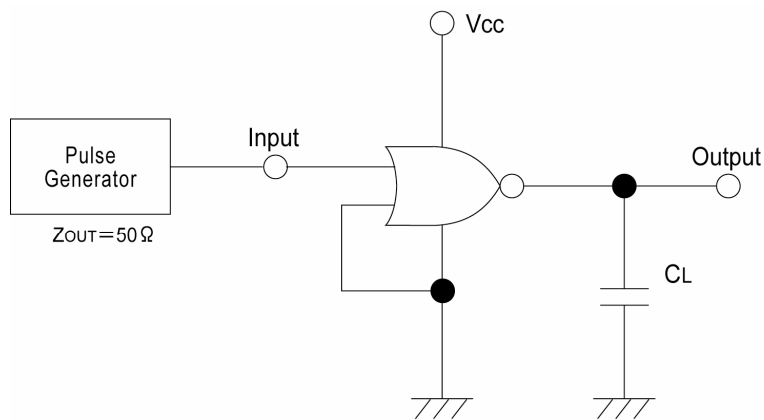

Note: Open output when measuring supply current

1. The products and product specifications contained herein are subject to change without notice to improve performance characteristics. Consult us, or our representatives before use, to confirm that the information in this catalog is up to date.
2. We assume no responsibility for any infringement of patents, patent rights, or other rights arising from the use of any information and circuitry in this catalog.
3. Please ensure suitable shipping controls (including fail-safe designs and aging protection) are in force for equipment employing products listed in this catalog.
4. The products in this catalog are not developed, designed, or approved for use with such equipment whose failure or malfunction can be reasonably expected to directly endanger the life of, or cause significant injury to, the user.
(e.g. Atomic energy; aerospace; transport; combustion and associated safety equipment thereof.)
5. Please use the products listed in this catalog within the specified ranges.
Should you wish to use the products under conditions exceeding the specifications, please consult us or our representatives.
6. We assume no responsibility for damage or loss due to abnormal use.
7. All rights reserved. No part of this catalog may be copied or reproduced without the prior permission of Torex Semiconductor Ltd.

TOREX SEMICONDUCTOR LTD.