

SML12RG3-TR

Hi-Eff Red/Hi-Eff Green

Surface Mount LED

3.0 × 1.5 × 1.0 mm Chip LED

100° viewing angle

DWG BY:
BL / GP
02-23-07

CHK BY:
PL
08-20-07

QA:
—
— - - -

MFG:
—
— - - -

REVISION LTR: -
08-20-07

● **Features:**

1. Emitted Color :Hi-Eff Red and Hi-Eff Green
2. Lens Appearance : Water Clear.
3. Bi-color type.
4. 3.0x1.5x1.0mm standard package.
5. Suitable for all SMT assembly methods.
6. Compatible with infrared and vapor phase reflow solder process.
7. Compatible with automatic placement equipment.
8. This product is RoHS compliant.

● **Applications:**

1. Automotive : Dashboards, stop lamps, turn signals.
2. Backlighting : LCDs, Key pads advertising.
3. Status indicators : Comsumer & industrial electronics.
4. General use.

● **Package Dimensions:**

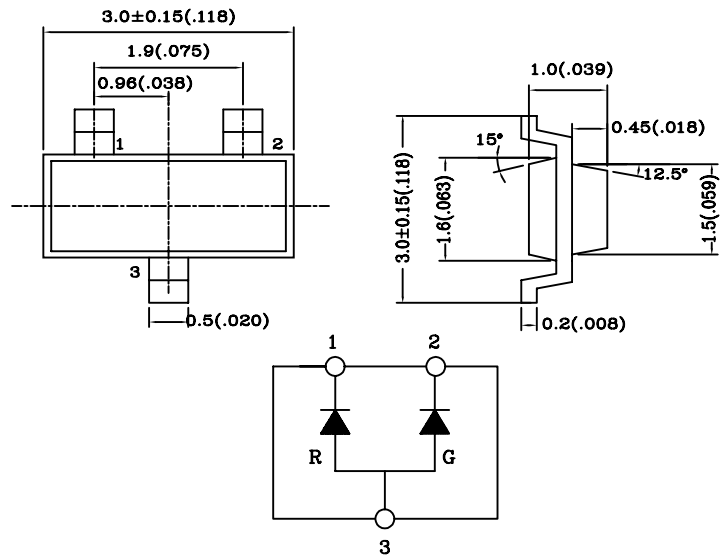

NOTES:

- 1.All dimensions are in millimeters (inches).
- 2.Tolerance is ±0.10mm (0.004") unless otherwise specified.
- 3.Specifications are subject to change without notice.

● **Absolute Maximum Ratings(Ta=25 °C)**

Parameter	Symbol	Hi-Eff Red	Hi-Eff Green	Unit
Power Dissipation	Pd	80	80	mW
Forward Current	I _F	30	30	mA
Peak Forward Current * 1	I _{FP}	100	100	mA
Reverse Volage	V _R	5		V
Operating Temperature	Topr	-25 °C ~80 °C		-
Storage Temperature	Tstg	-30 °C ~85 °C		-
Soldering Temperature	Tsol	See Page5		-

* 1 Condition for I_{FP} is pulse of 1/10 duty and 0.1msec width.

● **Electrical and optical characteristics(Ta=25°C)**

Parameter	Symbol	Condition	Color	Min.	Typ.	Max.	Unit
Forward Voltage	V _f	I _F =20mA	Hi-Eff Red Hi-Eff Green	-	2.0 2.2	2.8 2.8	V
Luminous Intensity	I _v	I _F =20mA	Hi-Eff Red Hi-Eff Green	- -	5 9	-	mcd
Reverse Current	I _R	V _R =5V	Hi-Eff Red Hi-Eff Green	-	-	100	μA
Peak Wave Length	λ _p	I _F =20mA	Hi-Eff Red Hi-Eff Green	625 565	628 567	633 568	nm
Dominant Wave Length	λ _d	I _F =20mA	Hi-Eff Red Hi-Eff Green	615 570	617 572	620 573	nm
Spectral Line Half-width	Δλ	I _F =20mA	Hi-Eff Red Hi-Eff Green	-	42 30	-	nm
Viewing Angle	2θ _{1/2}	I _F =20mA	Hi-Eff Red Hi-Eff Green	-	100	-	deg
Chromaticity Coordinates	X	I _F =20mA	Hi-Eff Red	-	0.68	-	
	Y			-	0.31	-	
Chromaticity Coordinates	X	I _F =20mA	Hi-Eff Green	-	0.46	-	
	Y			-	0.53	-	

● **Typical Electro-Optical Characteristics Curves**

Fig.1 RELATIVE INTENSITY VS. WAVELENGTH

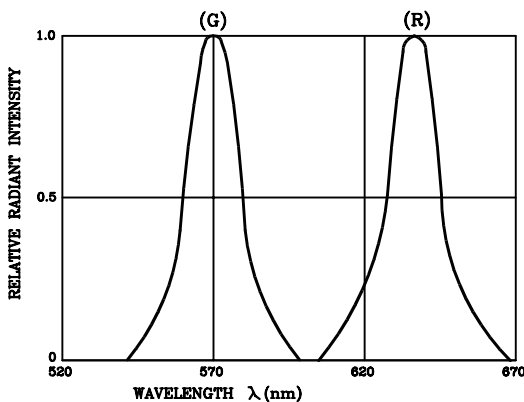

Fig.2 FORWARD CURRENT DERATING CURVE

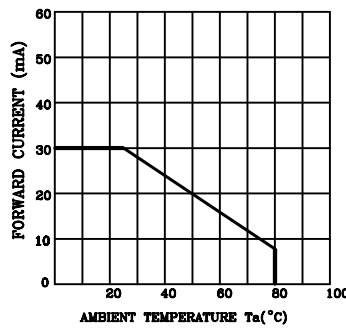

Fig.3 FORWARD CURRENT VS. FORWARD VOLTAGE

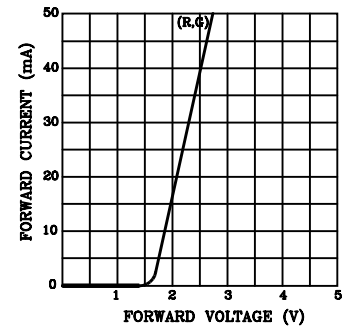

Fig.4 RELATIVE LUMINOUS INTENSITY VS. AMBIENT TEMPERATURE

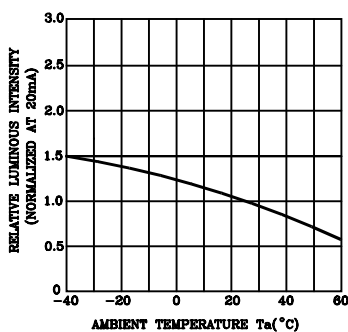

Fig.5 RELATIVE LUMINOUS INTENSITY VS. FORWARD CURRENT

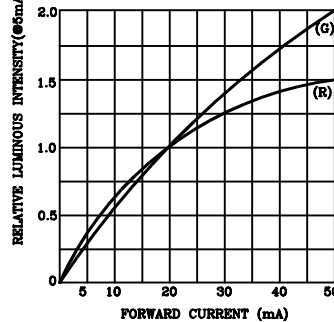
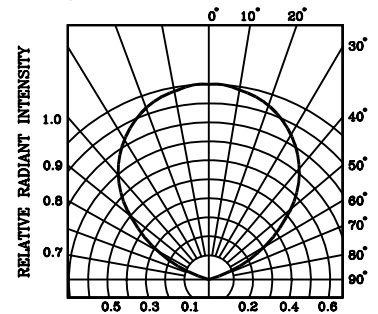
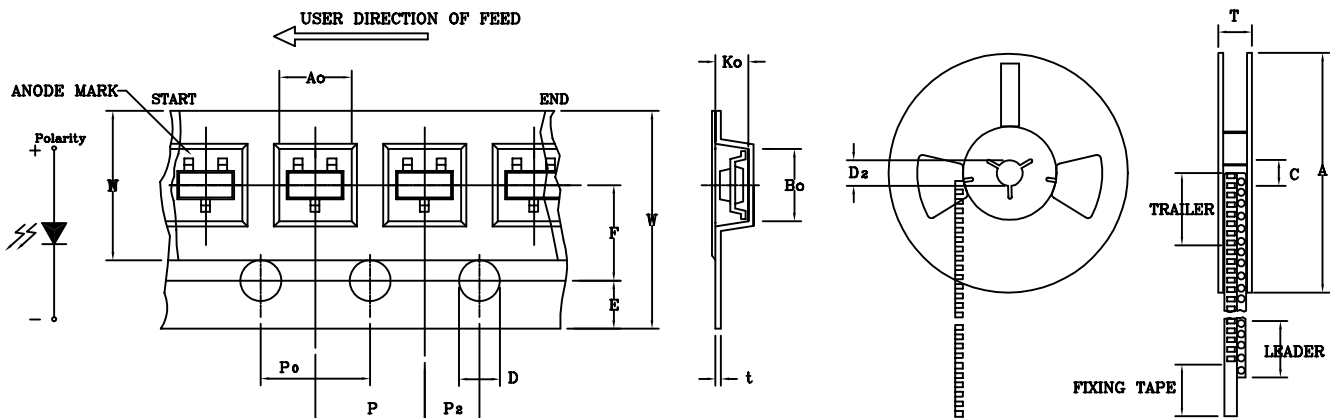

Fig.6 RADIATION DIAGRAM



ITEM	SYMBOL	SPECIFICATION			
		Minimum		Maximum	
		mm	inch	mm	inch
Tape Feed Hole Diameter (DIA)	D	1.50	0.059	1.60	0.063
Feed Hole Location	E	1.65	0.064	1.85	0.073
Centers Line Dimensions Length Direction	F	3.45	0.135	3.55	0.139
Compartment Depth	K ₀	1.40	0.049	1.60	0.057
Compartment Pitch	P	3.90	0.153	4.10	0.161
Sprocket Hole Diameter	P ₀	3.90	0.153	4.10	0.161
Centers Line Dimensions Length Direction	P ₂	1.95	0.076	2.05	0.080
Carrier Tape Thickness	t	—	—	0.30	0.012
Carrier Tape Width	W	7.70	0.303	8.30	0.326
Flange Diameter	A	176.0	6.928	180.0	7.087
Hub Spindle Hole	C	12.50	0.492	13.50	0.531
Hub Diameter	D ₂	20.10	0.791	20.30	0.799
Fixing Tape Width	N	59.00	2.322	61.00	2.402
Flange Space Between Flanges	T	14.30	0.563	14.50	0.571
Compartment Length	A ₀	3.10	0.122	3.20	0.130
Compartment Width	B ₀	3.10	0.122	3.20	0.130



NOTE: 3000 pcs PER REEL

● **Reliability Test**

Classification	Test Item	Reference Standard	Test Conditions	Result
Endurance Test	Operation Life	MIL-STD-750:1026 MIL-STD-883:1005 JIS-C-7021 :B-1	Connect with a power $I_f=20\text{mA}$ T_a =Under room temperature Test time=1,000hrs	0/20
	High Temperature High Humidity Storage	MIL-STD-202:103B JIS-C-7021 :B-11	$T_a=+65^\circ\text{C}\pm 5^\circ\text{C}$ RH=90%-95% Test time=240hrs	0/20
	High Temperature Storage	MIL-STD-883:1008 JIS-C-7021 :B-10	High $T_a=+85^\circ\text{C}\pm 5^\circ\text{C}$ Test time=1,000hrs	0/20
	Low Temperature Storage	JIS-C-7021 :B-12	Low $T_a=-35^\circ\text{C}\pm 5^\circ\text{C}$ Test time=1,000hrs	0/20
Environmental Test	Temperature Cycling	MIL-STD-202:107D MIL-STD-750:1051 MIL-STD-883:1010 JIS-C-7021 :A-4	$-35^\circ\text{C} \sim +25^\circ\text{C} \sim +85^\circ\text{C} \sim +25^\circ\text{C}$ 60min 20min 60min 20min Test Time=5cycle	0/20
	Thermal Shock	MIL-STD-202:107D MIL-STD-750:1051 MIL-STD-883:1011	$-85^\circ\text{C}\pm 5^\circ\text{C} \sim +35^\circ\text{C}\pm 5^\circ\text{C}$ 20min 20min Test Time=10cycle	0/20
	Solder Resistance	MIL-STD-202:201A MIL-STD-750:2031 JIS-C-7021 :A-1	Preheating: $140^\circ\text{C}-160^\circ\text{C}$, within 2 minutes. Operation heating: 235°C (Max.), within 10seconds. (Max.)	0/20

● **Judgment criteria of failure for reliability**

Measuring items	Symbol	Measuring conditions	Judgement criteria for failure
Forward voltage	V_F (V)	$I_F=20\text{mA}$	Over $U_x1.2$
Reverse current	I_R (μA)	$V_R=5\text{V}$	Over U_x2
Luminous intensity	I_v (mcd)	$I_F=20\text{mA}$	Below $SX0.5$

Note: 1.U means the upper limit of specified characteristics. S means initial value.

2.Measurement shall be taken between 2 hours and after the test pieces have been returned to normal ambient conditions after completion of each test.

1. Soldering :

● Manual Of Soldering

The temperature of the iron tip should not be higher than 300°C(572°F) and Soldering within 3 seconds per solder-land is to be observed.

● Reflow Soldering

Preheating : 140°C~160°C±5°C, within 2 minutes.
 Operation heating : 235°C (Max.) within 10 seconds.(Max)
 Gradual Cooling (Avoid quenching).

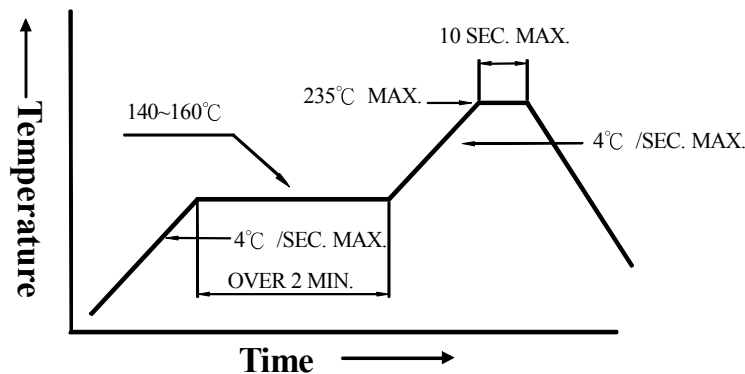

● DIP soldering (Wave Soldering) :

Preheating : 120°C~150°C, within 120~180 sec.
 Operation heating : 245°C±5°C within 5 sec. 260°C (Max)
 Gradual Cooling (Avoid quenching).

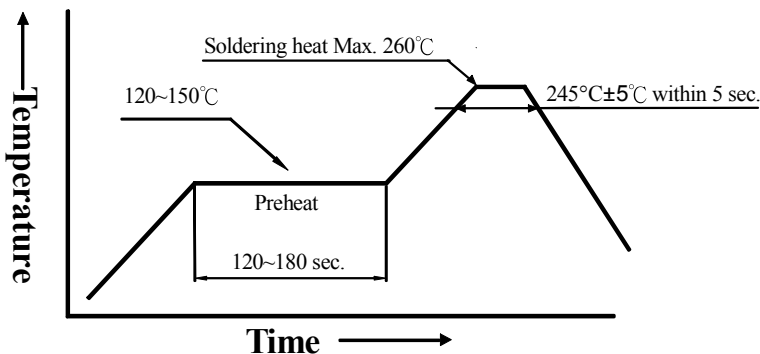

2. Handling

Care must be taken not to cause damage to the epoxy resin portion of LEDs while it is exposed to high temperatures, or abrade the epoxy resin portion of LEDs with hard or sharp items as from sand blasting and the use of sharp metallic objects.

3. Notes for designing

Care must be taken to provide the current limiting resistor in the circuit so as to drive the LEDs within the rated figures. Also, caution should be taken not to overload LEDs with instantaneous voltage at the turning ON and OFF of the circuit. When using the pulse drive care must be taken to keep the average current within the rated figures. Also, the circuit should be designed so as to be subjected to reverse voltage when turning off the LEDs.

4. Storage:

In order to avoid the absorption of moisture, it is recommended to solder LEDs as soon as possible after unpacking the sealed envelope.

If the envelope is still packed, store it in the following environment:

- (1) Temperature: 5°C-30°C (41°F-86°F) Humidity: RH 60% Max.
- (2) After this bag is opened, devices that will be applied to infrared reflow, vapor-phase reflow, or equivalent soldering process must be:
 - a. Completed within 24 hours.
 - b. Stored at less than 30% RH
- (3) Devices require baking before mounting if: (2)a or (2)b is not met.
- (4) If baking is required, devices must be baked under below conditions:
 - 12 hours at 60°C ±3°C