

# SML1209-0CW-TR

Super Cool White

Dome Lens Surface Mount LED

3.2 × 2.4 × 2.5 mm Chip LED

25° viewing angle

DWG BY:  
SL / JG  
12-12-06

CHK BY:  
PL  
07-25-08

QA:  
RD  
07-25-08

MFG:  
—  
— — —

REVISION LTR: A  
ECR# 072508-RD01  
07-25-08

## Package Dimensions:

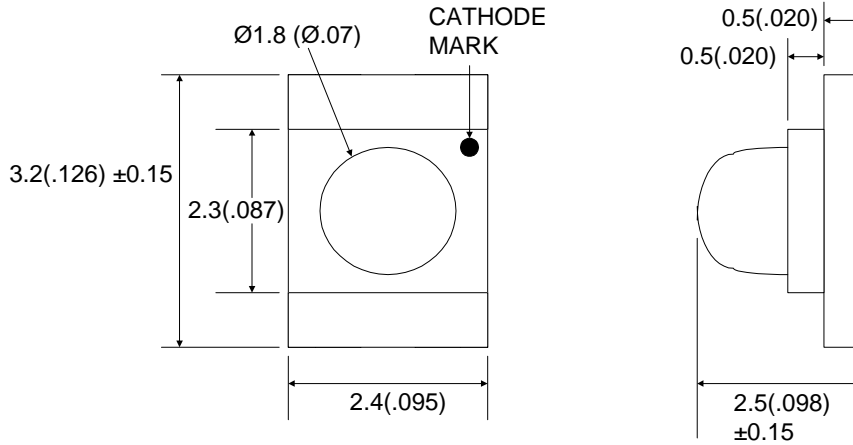

| Part No.       | Chip Material | Lens Color  | Emission Color   |
|----------------|---------------|-------------|------------------|
| SML1209-0CW-TR | InGaN         | Water Clear | Super Cool White |

### Notes:

1. All dimensions are in millimeters (inches).
2. Tolerance is ±0.25mm (.010") unless otherwise noted.
3. Termination base metal: Cu. Plating: Au over Ni.
4. Specifications are subject to change without notice.
5. Precautions for ESD:  
 Static electricity and surge can damage the LED. It is recommended to use a wristband or anti-electrostatic glove when handling the LED. All devices, equipment and machinery must be properly grounded.

| <b>Absolute Maximum Ratings</b>          |                  |              |             |
|--|------------------|--------------|-------------|
| <b>(T<sub>A</sub>=25° C)</b>             |                  |              |             |
| <b>Parameter</b>                         | <b>Symbol</b>    | <b>Value</b> | <b>Unit</b> |
| Average forward current                  | I <sub>af</sub>  | 30           | mA          |
| Reverse voltage                          | V <sub>i</sub>   | 5            | V           |
| Power dissipation                        | P <sub>d</sub>   | 111          | mW          |
| Operating temperature range              | T <sub>opr</sub> | -40 ~+85     | °C          |
| Storage temperature range                | T <sub>stg</sub> | -40 ~+85     | °C          |
| Peak forward current (Duty = 0.1, 1 KHz) | I <sub>fp</sub>  | 100          | mA          |

| <b>Electro-optical characteristics</b> |                       |                   |              |            |            |             |
|--|-----------------------|-------------------|--------------|------------|------------|-------------|
| <b>(T<sub>A</sub>=25° C)</b>           |                       |                   |              |            |            |             |
| <b>Parameter</b>                       | <b>Test Condition</b> | <b>Symbol</b>     | <b>Value</b> |            |            | <b>Unit</b> |
|  |                       |                   | <b>Min</b>   | <b>Typ</b> | <b>Max</b> |             |
| Wavelength at peak emission            | I <sub>f</sub> =20mA  | λ <sub>p</sub>    | --           | --         | --         | nm          |
| Spectral half bandwidth                | I <sub>f</sub> =20mA  | Δλ                | --           | --         | --         | nm          |
| Dominant wavelength                    | I <sub>f</sub> =20mA  | λ <sub>d</sub>    | --           | --         | --         | nm          |
| Forward voltage                        | I <sub>f</sub> =20mA  | V <sub>f</sub>    | --           | 3.2        | 4.0        | V           |
| Luminous intensity *1                  | I <sub>f</sub> =20mA  | I <sub>v</sub>    | 100          | 200        | --         | mcd         |
| Viewing angle at 50% I <sub>v</sub>    | I <sub>f</sub> =20mA  | 2θ <sub>1/2</sub> | --           | 25         | --         | Deg         |
| Reverse current                        | V <sub>r</sub> =5V    | I <sub>r</sub>    | --           | --         | 100        | μA          |
| Chromaticity coordinates               | I <sub>f</sub> =20mA  | X                 | --           | 0.28       | --         |             |
|  |                       | Y                 |              | 0.28       |            |             |
| Radiant intensity                      | I <sub>f</sub> =20mA  | I <sub>e</sub>    | --           | --         | --         | μW/sr       |

\* 1 Note: Luminous intensity tolerance is ±10%

# OPTICAL CHARACTERISTIC CURVES

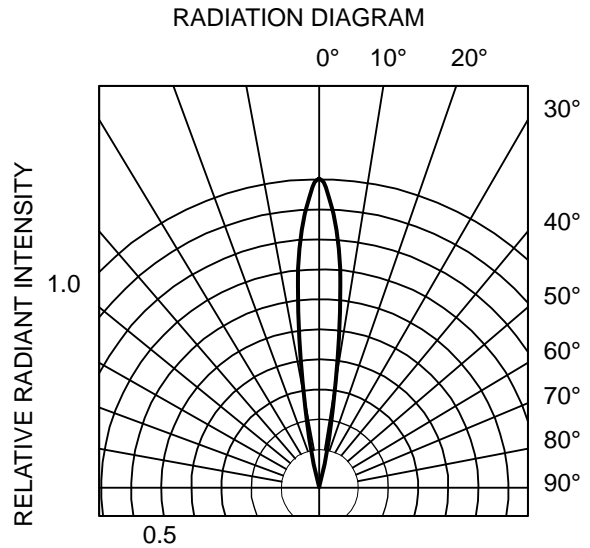
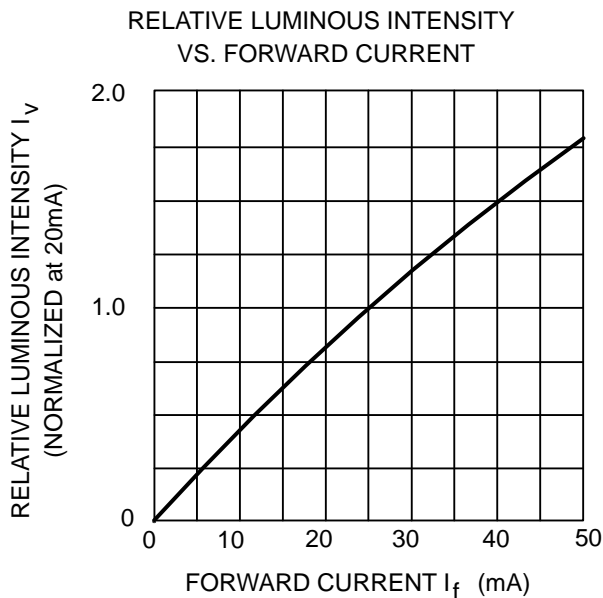
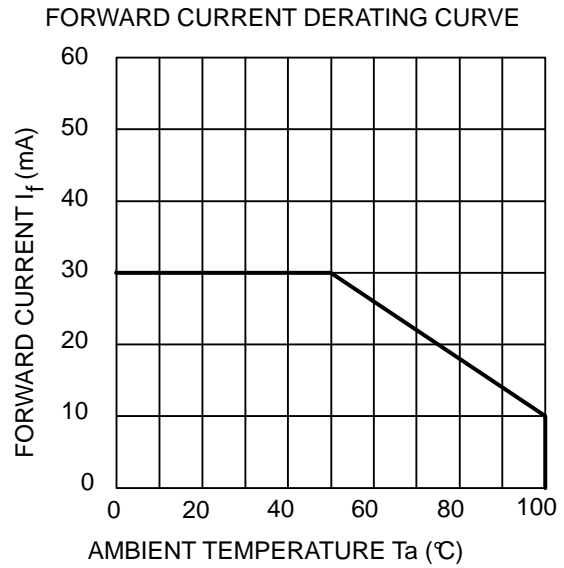
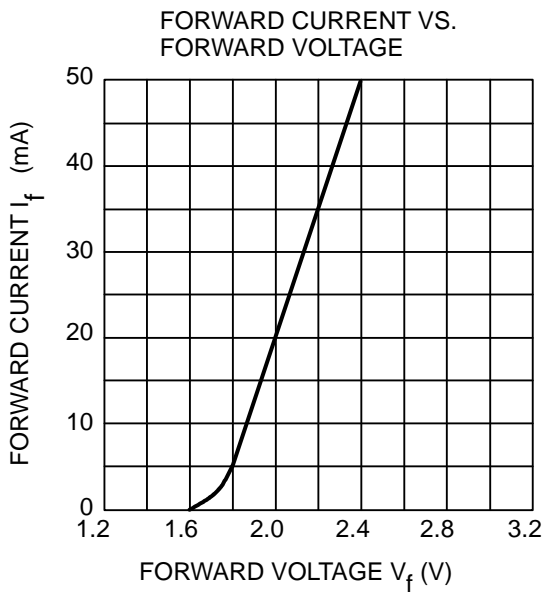
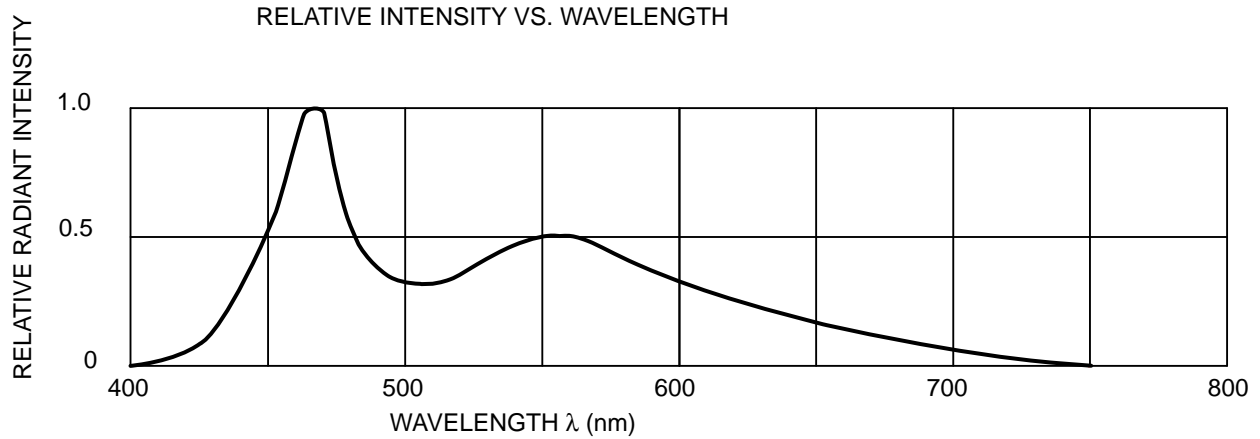

# SMD Chip LED Lamps Packaging Specifications

## ● Feeding

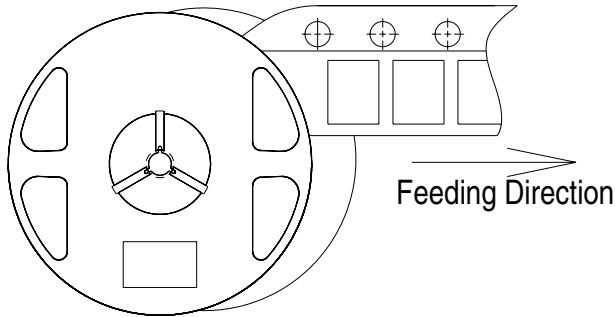

## ● Dimensions of Reel (Unit: mm)

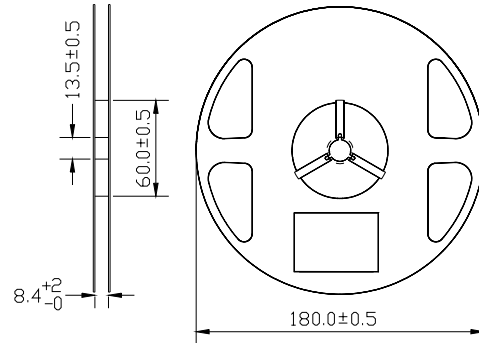

## ● Dimensions of Tape (Unit: mm)

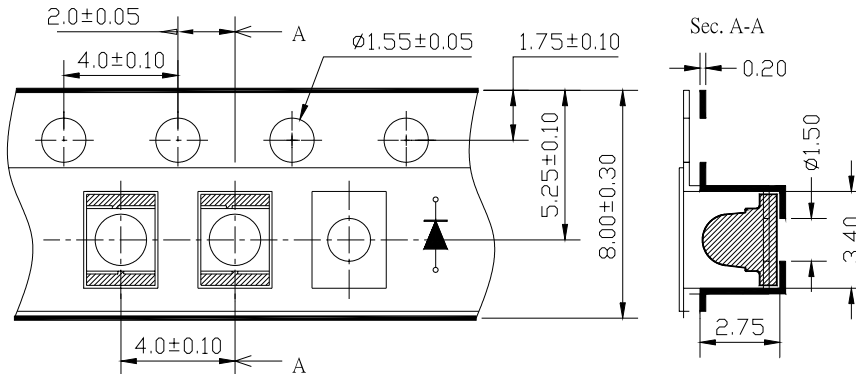

## ● Arrangement of Tape

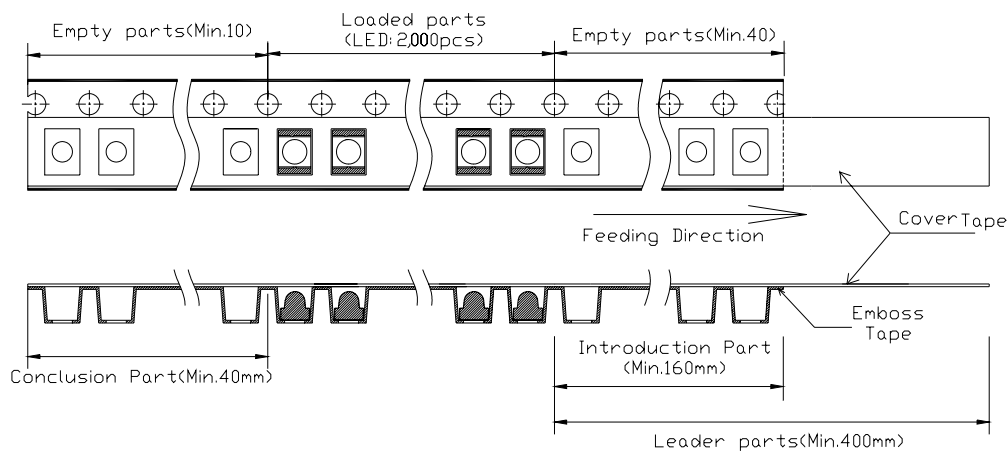

### NOTES

1. Empty component pockets are sealed with top cover tape;
2. The maximum number of missing lamps is two;
3. The cathode is oriented towards the tape sprocket hole in accordance with ANSI/EIA RS-481 specifications.
4. 2,000 pcs/Reel



### Test items and results of reliability

| Type                   | Test Item                    | Test Conditions                               | Note      | Number of Damaged |
|------------------------|------------------------------|---|-----------|-------------------|
| Environmental Sequence | Temperature Cycle            | -20°C 30min<br>↑ ↓<br>80°C 30min              | 100 cycle | 0/22              |
|                        | Thermal Shock                | -20°C 15min<br>↑ ↓<br>80°C 15min              | 100 cycle | 0/22              |
|                        | High Humidity Heat Cycle     | 30°C ↔ 65°C<br>90%RH 24hrs/1cycle             | 10 cycle  | 0/22              |
|                        | High Temperature Storage     | T <sub>a</sub> =80°C                          | 1000 hrs  | 0/22              |
|                        | Humidity Heat Storage        | T <sub>a</sub> =60°C<br>RH=90%                | 1000 hrs  | 0/22              |
|                        | Low Temperature Storage      | T <sub>a</sub> =-30°C                         | 1000 hrs  | 0/22              |
| Operation Sequence     | Life Test                    | T <sub>a</sub> =25°C<br>I <sub>F</sub> =20mA  | 1000 hrs  | 0/22              |
|                        | High Humidity Heat Life Test | 60°C RH=90%<br>I <sub>F</sub> =10mA           | 500 hrs   | 0/22              |
|                        | Low Temperature Life Test    | T <sub>a</sub> =-20°C<br>I <sub>F</sub> =20mA | 1000 hrs  | 0/22              |

## Reflow Profile

### ■ Reflow Temp/Time

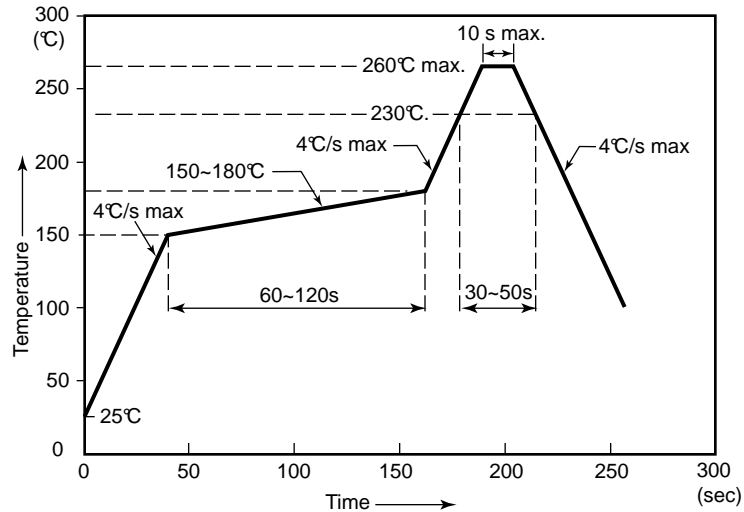

### NOTES:

1. Recommended reflow lead soldering temperature at  $250^{\circ}\text{C} \pm 5^{\circ}\text{C}$  for 3 seconds (0.063in. [1.6mm] from body).  
The maximum soldering temperature should be limited to  $260^{\circ}\text{C}$ .
2. Don't cause stress to the epoxy resin while it is exposed to high temperature.
3. Number of reflow process shall be 2 times or less.

### ■ Soldering iron

Basic spec is  $\leq 5\text{sec}$  when  $260^{\circ}\text{C}$ . If temperature is higher, time should be shorter ( $+10^{\circ}\text{C} \rightarrow -1\text{sec}$ ). Power dissipation of iron should be smaller than 15W, and temperatures should be controllable. Surface temperature of the device should be under  $230^{\circ}\text{C}$ .

### ■ Rework

1. Customer must finish rework within 5 sec under  $260^{\circ}\text{C}$ .
2. The head of iron cannot touch copper foil.
3. Twin-head type is preferred.

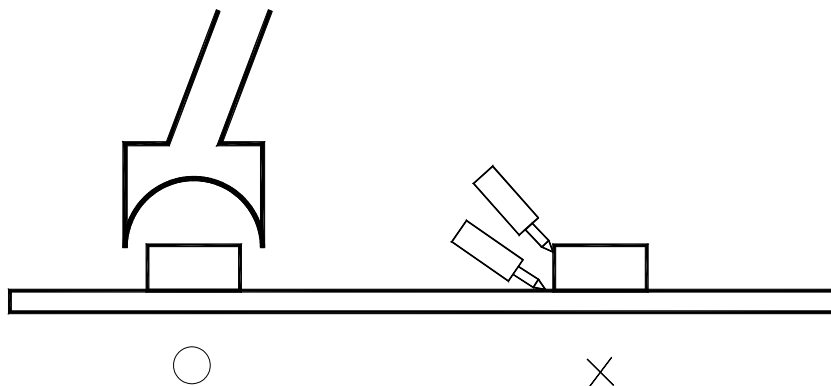

## Test circuit and handling precautions

### ■ Test circuit

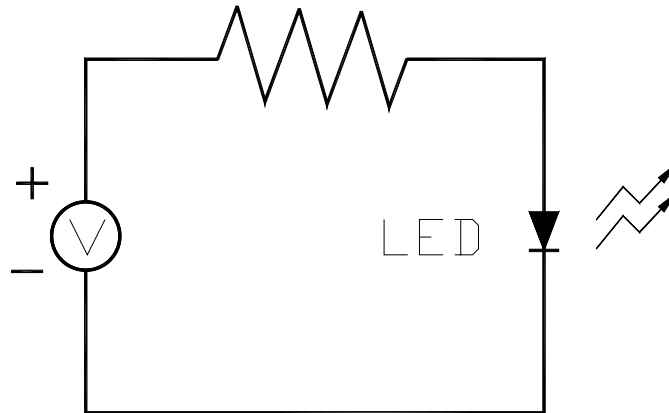

### ■ Handling precautions

#### 1. Over-current-proof

Customer must apply resistors for protection; otherwise a slight voltage shift will cause a big change in current (Burnout occurs).

#### 2.Storage

2.1 It is recommended to store the products in the following conditions:

Humidity: 60% R.H. Max.

Temperature : 5°C~30°C (41°F~86°F)

2.2 Shelf life in sealed bag: 12 months at < 5°C~30°C and < 30% R.H. after the package is opened, the products should be used within a week or they should be kept stored at  $\leq$  20 R.H. with zip-lock seal.

#### 3.Baking

It is recommended to bake before soldering when the pack is unsealed after 72hrs.

The conditions are as follows:

3.1 60±3°C x(12~24hrs) and < 5%RH, taped reel type

3.2 100±3°C x(45min~1hr), bulk type

3.3 130±3°C x(15~30min), bulk type