

SML1205-2CW-TR

White

Surface Mount LED

4.0 × 0.8 × 1.4 mm Chip LED

120° viewing angle

DWG BY:
BL / GP
11-16-06

CHK BY:
PL
12-13-06

QA:
__-__-06

MFG:
__-__-__

REVISION LTR: -
12-13-06

● **Features:**

1. Emitted Color : White
2. Mono-color type.
3. 4.0x0.8x1.4mm tandard package
4. Suitable for all SMT assembly methods.
5. Compatible with infrared and vapor phase reflow solder process.
6. Compatible with automatic placement equipment.
7. This product is RoHS compliant.

● **Applications:**

1. Automotive : Dashboards, stop lamps, turn signals.
2. Backlighting : LCDs.
3. Status indicators : Comsumer & industrial electronics.
4. General use.

● **Package Dimensions:**

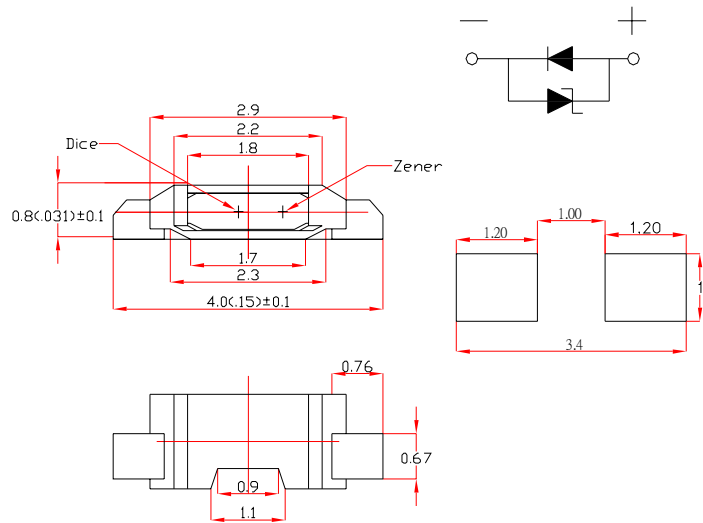

NOTES:

1. All dimensions are in millimeters (inches).
2. Tolerance is $\pm 0.10\text{mm}$ (0.004") unless otherwise specified.
3. Specifications are subject to change without notice.

● **Absolute Maximum Ratings(Ta=25°C)**

Parameter	Symbol	Rating	Unit
Power Dissipation	Pd	120	mW
Forward Current	I _F	30	mA
Peak Forward Current * 1	I _{FP}	100	mA
Reverse Volage	V _R	5	V
Operating Temperature	Topr	-35°C~85°C	°C-
Storage Temperature	Tstg	-40°C~100°C	-
Soldering Temperature	Tsol	See Page7	-

* 1 Condition for I_{FP} is pulse of 1/10 duty and 0.1msec width.

● **Electrical and optical characteristics(Ta=25°C)**

Parameter	Symbol	Condition	Min.	Typ.	Max.	Unit
Forward Voltage	V _F	I _F =20mA	2.8	3.3	3.8	V
Luminous Intensity	I _v	I _F =20mA	600	1000	1300	mcd
Reverse Current	I _R	V _R =5V	-	-	10	μA
Peak Wave Length	λ _p	I _F =20mA	-	460	-	nm
Dominant Wave Length	λ _d	I _F =20mA	-	474	-	nm
Spectral Line Half-width	Δλ	I _F =20mA	-	-	-	nm
Viewing Angle	2θ _{1/2}	I _F =20mA	-	120	-	deg
Radiant Intensity		I _F =20mA	-	3500	-	μW/sr
Chromaticity Coordinates	X	I _F =20mA	0.28	0.30	0.32	
	Y		0.28	0.30	0.32	

● **Typical Electro-Optical Characteristics Curves**

Fig.1 Relative intensity vs. wavelength

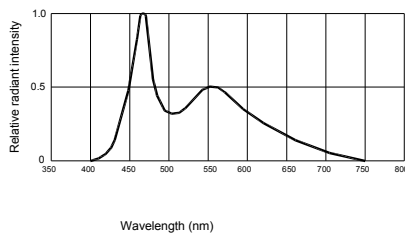

Fig.2 Forward current derating curve vs. ambient temperature

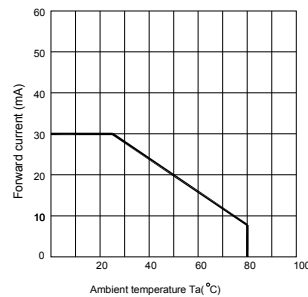

Fig.3 Forward current vs. forward voltage

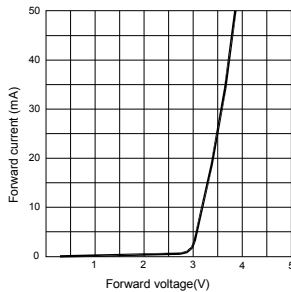

Fig.4 Relative luminous intensity vs. ambient temperature

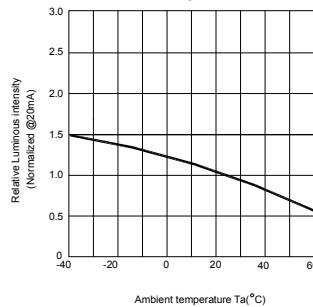

Fig.5 Relative luminous intensity vs. forward current

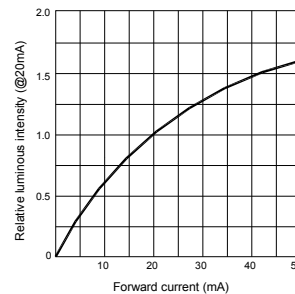

Fig.6 Radiation diagram

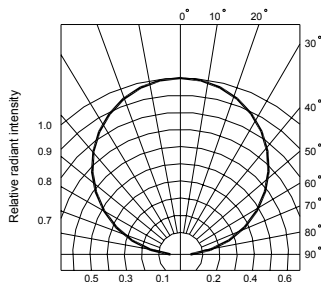

Fig.7 Forward current vs chromaticity coordinates

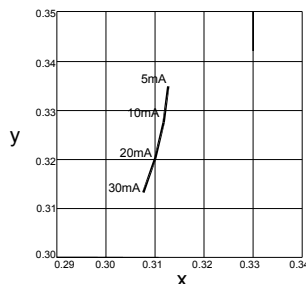
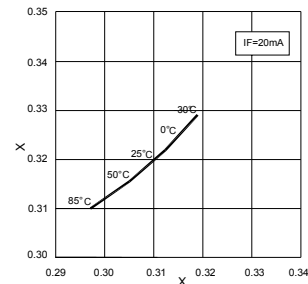
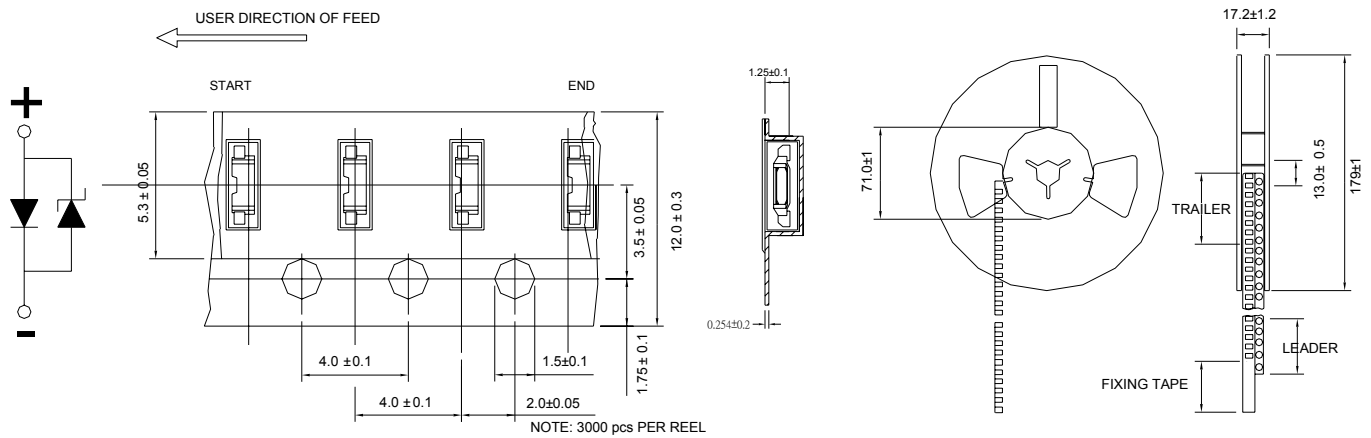

Fig.8 Ambient Temperature vs chromaticity coordinates



● **Tapping and packaging specifications(Units: mm)**



● **Bin Limits**

Intensity Bin Limits (@20mA):

BIN CODE	Min. (mcd)	Max. (mcd)
F	600	700
G	700	800
H	800	900
J	900	1000
K	1000	1100
L	1100	1200
M	1200	1300

VF Bin Limits (@20mA):

BIN CODE	Min.(v)	Max.(v)
G1	2.80	2.90
G2	2.90	3.00
H1	3.00	3.10
H2	3.10	3.20
J1	3.20	3.30
J2	3.30	3.40

Color Bin Limits(@20mA):

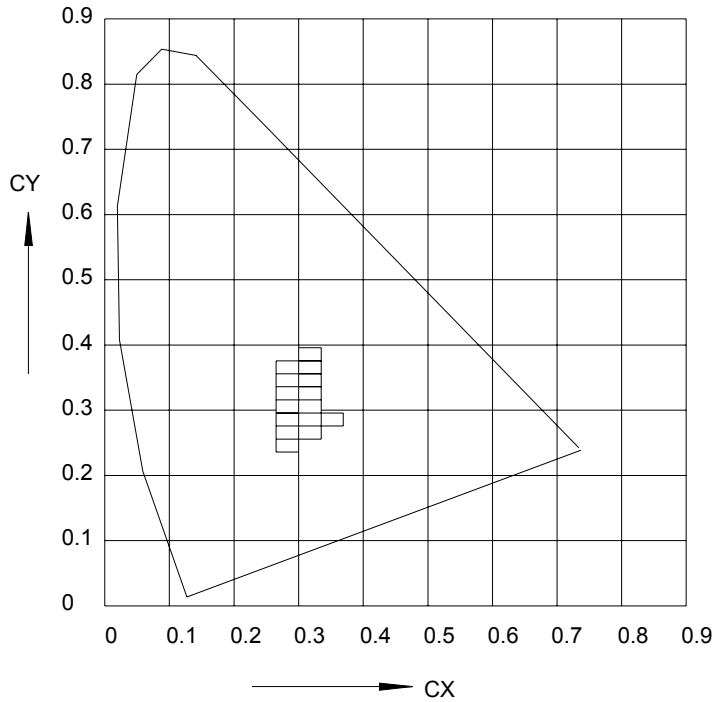

C.I.E CHROMATICITY DIAGRAM

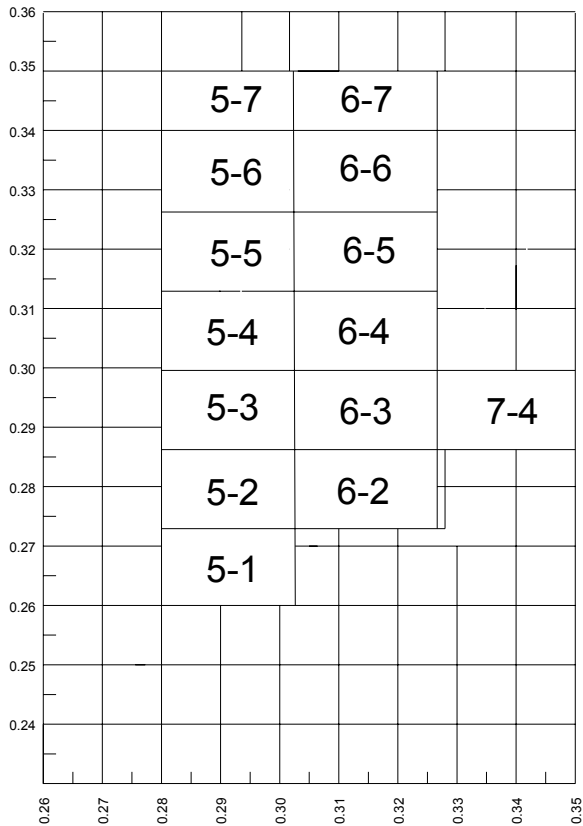

Color Bin Limits(@20mA):

BIN	Chromaticity Coordinates				
	x	y	z	u	v
5-1	x	0.280	0.270	0.280	0.270
	y	0.240	0.240	0.250	0.250
5-2	x	0.280	0.270	0.280	0.270
	y	0.250	0.250	0.260	0.260
5-3	x	0.280	0.270	0.280	0.270
	y	0.260	0.260	0.270	0.270
5-4	x	0.290	0.280	0.280	0.290
	y	0.280	0.280	0.290	0.290
5-5	x	0.290	0.280	0.280	0.290
	y	0.290	0.290	0.300	0.300
5-6	x	0.290	0.280	0.280	0.290
	y	0.300	0.300	0.310	0.310
5-7	x	0.290	0.280	0.280	0.290
	y	0.310	0.310	0.320	0.320
6-2	x	0.300	0.290	0.290	0.300
	y	0.280	0.280	0.290	0.290
6-3	x	0.300	0.290	0.290	0.300
	y	0.290	0.290	0.300	0.300
6-4	x	0.300	0.290	0.290	0.300
	y	0.300	0.300	0.310	0.310
6-5	x	0.300	0.290	0.290	0.300
	y	0.310	0.310	0.320	0.320
6-6	x	0.300	0.290	0.290	0.300
	y	0.320	0.320	0.330	0.330
6-7	x	0.300	0.290	0.290	0.300
	y	0.330	0.330	0.340	0.340
7-4	x	0.310	0.300	0.300	0.031
	y	0.340	0.340	0.350	0.350

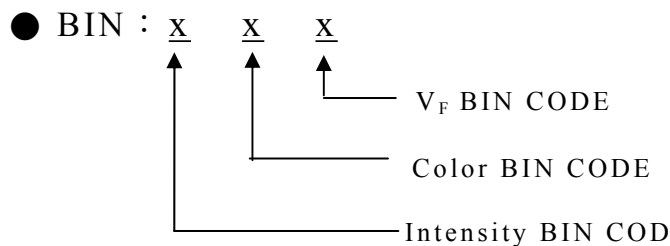

● **Reliability Test**

Classification	Test Item	Reference Standard	Test Conditions	Result
Endurance Test	Operation Life	MIL-STD-750:1026 MIL-STD-883:1005 JIS-C-7021 :B-1	Connect with a power $I_f=20\text{mA}$ T_a =Under room temperature Test time=1,000hrs	0/20
	High Temperature High Humidity Storage	MIL-STD-202:103B JIS-C-7021 :B-11	$T_a=+65^\circ\text{C}\pm 5^\circ\text{C}$ RH=90%-95% Test time=240hrs	0/20
	High Temperature Storage	MIL-STD-883:1008 JIS-C-7021 :B-10	High $T_a=+85^\circ\text{C}\pm 5^\circ\text{C}$ Test time=1,000hrs	0/20
	Low Temperature Storage	JIS-C-7021 :B-12	Low $T_a=-35^\circ\text{C}\pm 5^\circ\text{C}$ Test time=1,000hrs	0/20
Environmental Test	Temperature Cycling	MIL-STD-202:107D MIL-STD-750:1051 MIL-STD-883:1010 JIS-C-7021 :A-4	$-35^\circ\text{C} \sim +25^\circ\text{C} \sim +85^\circ\text{C} \sim +25^\circ\text{C}$ 60min 20min 60min 20min Test Time=5cycle	0/20
	Thermal Shock	MIL-STD-202:107D MIL-STD-750:1051 MIL-STD-883:1011	$-35^\circ\text{C}\pm 5^\circ\text{C} \sim +85^\circ\text{C}\pm 5^\circ\text{C}$ 20min 20min Test Time=10cycle	0/20
	Solder Resistance	MIL-STD-202:201A MIL-STD-750:2031 JIS-C-7021 :A-1	Preheating : $140^\circ\text{C}-160^\circ\text{C}$, within 2 minutes. Operation heating : 235°C (Max.), within 10seconds. (Max.)	0/20

● **Judgment criteria of failure for the reliability**

Measuring items	Symbol	Measuring conditions	Judgement criteria for failure
Forward voltage	V_F (V)	$I_F=20\text{mA}$	Over $U_x1.2$
Reverse current	I_R (μA)	$V_R=5\text{V}$	Over U_x2
Luminous intensity	I_v (mcd)	$I_F=20\text{mA}$	Below $SX0.5$

Note: 1.U means the upper limit of specified characteristics. S means initial value.

2.Measurment shall be taken between 2 hours and after the test pieces have been returned to normal ambient conditions after completion of each test.

● **Soldering :**

1. Manual Of Soldering

The temperature of the iron tip should not be higher than 300°C(572°F) and Soldering within 3 seconds per solder-land is to be observed.

2. Reflow Soldering

Preheating : 140°C~160°C±5°C, within 2 minutes.

Operation heating : 235°C (Max.) within 10 seconds.(Max)

Gradual Cooling (Avoid quenching).

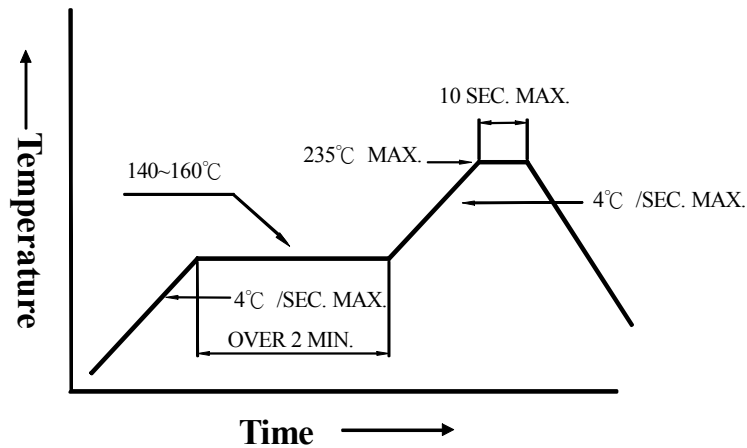

3. DIP soldering (Wave Soldering) :

Preheating : 120°C~150°C, within 120~180 sec.

Operation heating : 245°C±5°C within 5 sec. 260°C (Max)

Gradual Cooling (Avoid quenching).

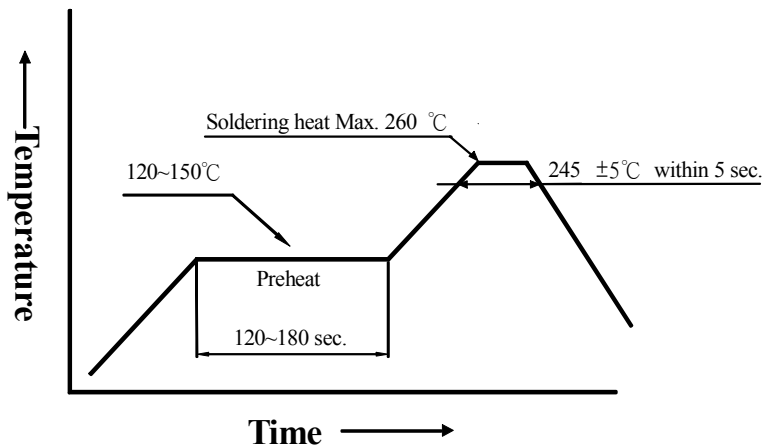

● **Handling :**

Care must be taken not to cause to the epoxy resin portion of LEDs while it is exposed to high temperature.

Care must be taken not rub the epoxy resin portion of LEDs with hard or sharp article such as the sand blast and the metal hook.