

# SML0603-Y4-TR

Yellow

Surface Mount LED

1.6 × 0.8 × 0.8 mm Chip LED

140° viewing angle

DWG BY:  
BL / MM  
03-07-07

CHK BY:  
PL  
03-08-07

QA:  
\_\_\_\_\_  
\_\_-\_\_-\_\_

MFG:  
\_\_\_\_\_  
\_\_-\_\_-\_\_

REVISION LTR: -  
03-07-07

● **Features:**

1. Emitted Color : Yellow
2. Lens Appearance : Water Clear
3. Mono-color type.
4. 1.6x0.8x0.8mm(0603) standard package
5. Suitable for all SMT assembly methods.
6. Compatible with infrared and vapor phase reflow solder process.
7. Compatible with automatic placement equipment.
8. This product is RoHS compliant.

● **Applications:**

1. Automotive : Dashboards, stop lamps, turn signals.
2. Backlighting : LCDs, Key pads advertising.
3. Status indicators : Comsumer & industrial electronics.
4. General use.

● **Package Dimensions:**

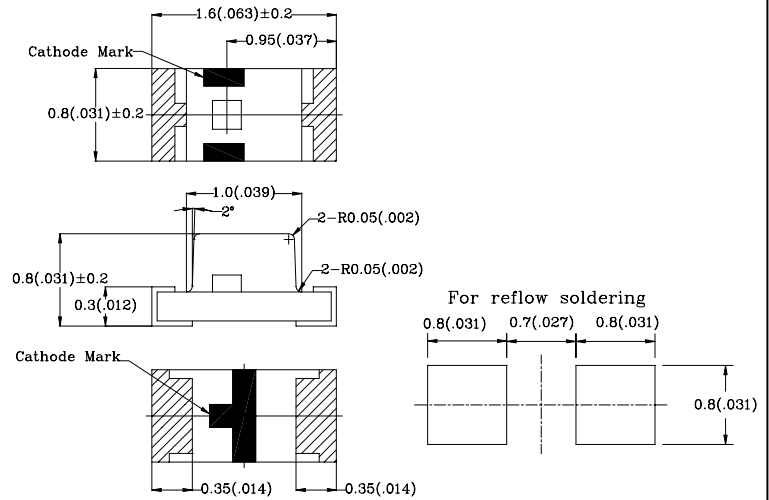

NOTES:

1. All dimensions are in millimeters (inches).
2. Tolerance is ±0.10mm (0.004") unless otherwise specified.
3. Specifications are subject to change without notice.

● **Absolute Maximum Ratings(Ta=25°C)**

Parameter	Symbol	Rating	Unit
Power Dissipation	Pd	100	mW
Forward Current	I <sub>F</sub>	30	mA
Peak Forward Current * 1	I <sub>FP</sub>	100	mA
Reverse Voltage	V <sub>R</sub>	5	V
Operating Temperature	T <sub>opr</sub>	-25°C ~80°C	-
Storage Temperature	T <sub>stg</sub>	-30°C ~85°C	-
Soldering Temperature	T <sub>sol</sub>	See Page6	-

\* 1 Condition for I<sub>FP</sub> is pulse of 1/10 duty and 0.1msec width.

● **Electrical and optical characteristics(Ta=25°C)**

Parameter	Symbol	Condition	Min.	Typ.	Max.	Unit
Forward Voltage	$V_F$	$I_F=20mA$	-	2.1	2.6	V
Luminous Intensity	$I_v$	$I_F=20mA$	2.4	6	-	mcd
Peak Wave Length	$\lambda_p$	$I_F=20mA$	582	586	593	nm
Dominant Wave Length	$\lambda_d$	$I_F=20mA$	582	588	592	nm
Spectral Line Half-width	$\Delta \lambda$	$I_F=20mA$	-	36	-	nm
Viewing Angle	$2\theta_{1/2}$	$I_F=20mA$	-	140	-	deg
Reverse Current	$I_R$	$V_R = 5V$	-	-	100	$\mu A$
Chromaticity Coordinates	X	$I_F=20mA$	-	0.56	-	
	Y		-	0.43	-	

● **Typical Electro-Optical Characteristics Curves**

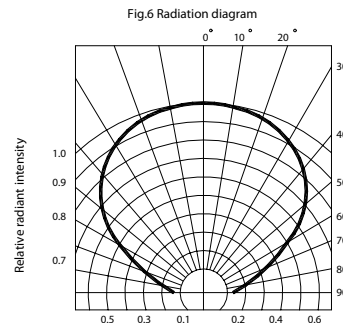
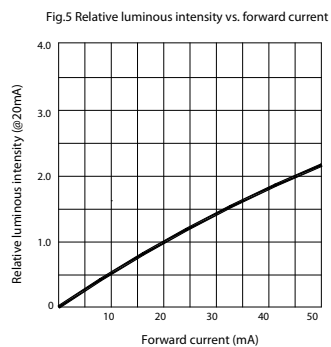
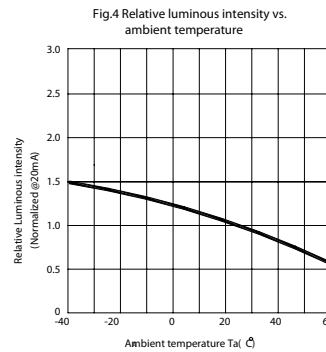
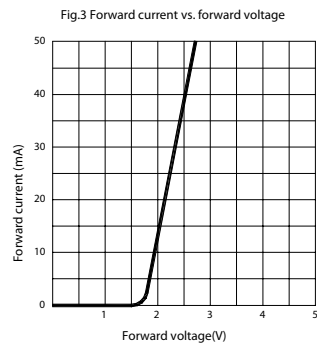
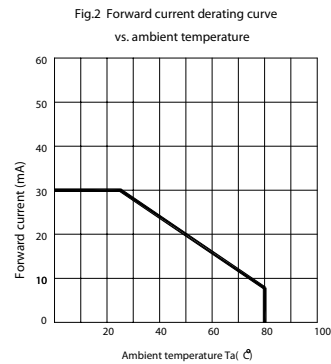
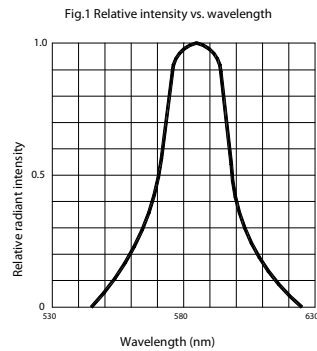

☒ **Tapping and packaging specifications(Units: mm)**

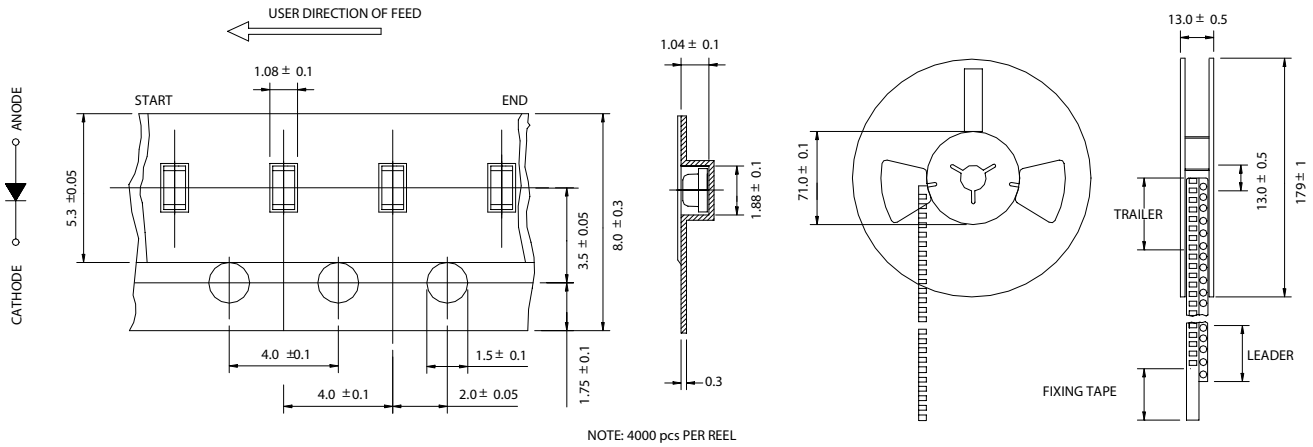

☒ **Bin Limits**

Intensity Bin Limits (At 20mA)

BIN CODE	Min. (mcd)	Max. (mcd)
F	2.1	4.2
G	3.2	6.3
H	4.8	9.4
J	7.0	14.0

☒ BIN : **X**  
 ↑  
 Intensity BIN CODE

● **Reliability Test**

Classification	Test Item	Reference Standard	Test Conditions	Result
Endurance Test	Operation Life	MIL-STD-750:1026 MIL-STD-883:1005 JIS-C-7021 :B-1	Connect with a power $I_f=20\text{mA}$ $T_a$ =Under room temperature Test time=1,000hrs	0/20
	High Temperature High Humidity Storage	MIL-STD-202:103B JIS-C-7021 :B-11	$T_a=+65^{\circ}\text{C}\pm 5^{\circ}\text{C}$ RH=90%-95% Test time=240hrs	0/20
	High Temperature Storage	MIL-STD-883:1008 JIS-C-7021 :B-10	High $T_a=+85^{\circ}\text{C}\pm 5^{\circ}\text{C}$ Test time=1,000hrs	0/20
	Low Temperature Storage	JIS-C-7021 :B-12	Low $T_a=-35^{\circ}\text{C}\pm 5^{\circ}\text{C}$ Test time=1,000hrs	0/20
Environmental Test	Temperature Cycling	MIL-STD-202:107D MIL-STD-750:1051 MIL-STD-883:1010 JIS-C-7021 :A-4	$-35^{\circ}\text{C} \sim +25^{\circ}\text{C} \sim +85^{\circ}\text{C} \sim +25^{\circ}\text{C}$ 60min 20min 60min 20min Test Time=5cycle	0/20
	Thermal Shock	MIL-STD-202:107D MIL-STD-750:1051 MIL-STD-883:1011	$-35^{\circ}\text{C}\pm 5^{\circ}\text{C} \sim +85^{\circ}\text{C}\pm 5^{\circ}\text{C}$ 20min 20min Test Time=10cycle	0/20
	Solder Resistance	MIL-STD-202:201A MIL-STD-750:2031 JIS-C-7021 :A-1	Preheating : $140^{\circ}\text{C}-160^{\circ}\text{C}$ , within 2 minutes. Operation heating : $235^{\circ}\text{C}$ (Max.), within 10seconds. (Max.)	0/20

● **Judgment criteria of failure for the reliability**

Measuring items	Symbol	Measuring conditions	Judgement criteria for failure
Forward voltage	$V_F$ (V)	$I_F=20\text{mA}$	Over $U_x1.2$
Reverse current	$I_R$ ( $\mu\text{A}$ )	$V_R=5\text{V}$	Over $U_x2$
Luminous intensity	$I_v$ (mcd)	$I_F=20\text{mA}$	Below $SX0.5$

Note: 1.U means the upper limit of specified characteristics. S means initial value.

2.Measurment shall be taken between 2 hours and after the test pieces have been returned to normal ambient conditions after completion of each test.

**1. Soldering**  
**Manual of Soldering**

The temperature of the iron tip should not be higher than 300°C (572°F) and soldering within 3 seconds per solder-land is to be observed.

**Reflow Soldering**

Preheating: 140°C~160°C ±5°C, within 2 minutes.  
 Operation heating: 260°C (Max.) within 10 seconds. (Max.)  
 Gradual Cooling (Avoid quenching).

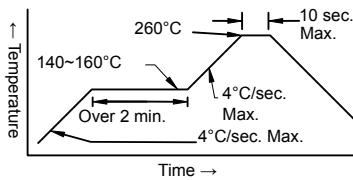

**DIP Soldering (Wave Soldering)**

Preheating: 120°C~150°C, within 120~180 sec.  
 Operation heating: 245°C ±5°C within 5 sec.  
 260°C (Max.)  
 Gradual Cooling (Avoid quenching).

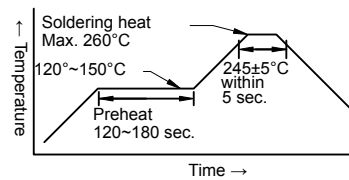

**2. Handling**

Care must be taken not to cause damage to the epoxy resin portion of LEDs while it is exposed to high temperatures, or abrade the epoxy resin portion of LEDs with hard or sharp items as from sand blasting and the use of sharp metallic objects.

**3. Notes for designing**

Care must be taken to provide the current limiting resistor in the circuit so as to drive the LEDs within the rated figures. Also, caution should be taken not to overload LEDs with instantaneous voltage at the turning ON and OFF of the circuit. When using the pulse drive care must be taken to keep the average current within the rated figures. Also, the circuit should be designed so as to be subjected to reverse voltage when turning off the LEDs.

**4. Storage:**

In order to avoid the absorption of moisture, it is recommended to solder LEDs as soon as possible after unpacking the sealed envelope. If the envelope is still packed, store it in the following environment:

- (1) Temperature: 5°C-30°C (41°F-86°F) Humidity: RH 60% Max.
- (2) After this bag is opened, devices that will be applied to infrared reflow, vapor-phase reflow, or equivalent soldering process must be:
  - a. Completed within 24 hours.
  - b. Stored at less than 30% RH
- (3) Devices require baking before mounting if: (2)a or (2)b is not met.
- (4) If baking is required, devices must be baked under below conditions:
  - 12 hours at 60°C ±3°C