



23105 Kashiwa Court, Torrance, CA 90505
Phone: (800) 579-4875 or (310) 534-1505 Fax: (310) 534-1424
E-mail: webmaster@ledtronics.com
Website: <http://www.ledtronics.com>

L200CWR5B

Hi-Eff Red

5mm, Flanged Cylindrical, 8.6mm Height
20° viewing angle

DWG BY:
BL / GP
09-19-06

CHK BY:
PL
08-07-08

QA:

__-__-__

MFG:

__-__-__

REVISION LTR: -

08-06-08

● **Features:**

1. Chip material: GaAsP/GaP
2. Emitted color : Hi-Eff Red
3. Lens Appearance : Water Clear
4. Low power consumption.
5. High efficiency.
6. Versatile mounting on P.C. Board or panel.
7. Low current requirement.
8. 5mm diameter package
9. This product is RoHS compliant.

● **Applications:**

1. TV set
2. Monitor
3. Telephone
4. Computer
5. Circuit board

● **Package dimensions**

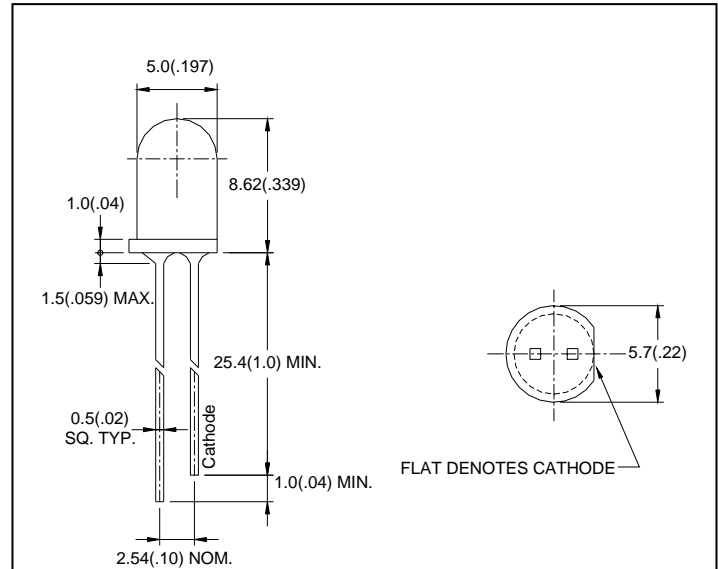

Notes:

1. All dimensions are in millimeters (inches).
2. Tolerance is $\pm 0.25\text{mm}$ ($0.01''$) unless otherwise specified.
3. Lead spacing is measured where the leads emerge from the package.
4. Specifications are subject to change without notice.

● **Absolute Maximum Ratings(Ta=25°C)**

Parameter	Symbol	Rating	Unit
Power Dissipation	Pd	80	mW
Forward Current	I _F	30	mA
Peak Forward Current* ¹	I _{FP}	150	mA
Reverse Voltage	V _R	5	V
Operating Temperature	Topr	-40°C ~80°C	
Storage Temperature	Tstg	-40°C ~85°C	
Soldering Temperature	Tsol	260°C (for 5 seconds)	

*¹Condition for I_{FP} is pulse of 1/10 duty and 0.1msec width.

● **Electrical and optical characteristics(Ta=25°C)**

Parameter	Symbol	Condition	Min.	Typ.	Max.	Unit
Forward Voltage	V_F	$I_F=20mA$	-	2.0	2.6	V
Luminous Intensity	I_v	$I_F=20mA$	-	200	-	mcd
Reverse Current	I_R	$V_R=5V$	-	-	100	μA
Peak Wave Length	λ_p	$I_F=20mA$	-	644	-	nm
Dominant Wave Length	λ_d	$I_F=20mA$	-	629	-	nm
Spectral Line Half-width	$\Delta \lambda$	$I_F=20mA$	-	43	-	nm
Viewing Angle	$2\theta_{1/2}$	$I_F=20mA$	-	20	-	deg
Radiant Intensity		$I_F=20mA$	-	2000	-	$\mu W/sr$
Chromaticity Coordinates	X	$I_F=20mA$	-	0.70	-	
	Y		-	0.29	-	

● **Typical Electro-Optical Characteristics Curves**

