

L200CWRGB1KN-4C-IL

Super Red/Aqua Green/Blue

5mm, Flanged Cylindrical, 8.6mm Height
20° viewing angle

DWG BY:

BL / GP

10-20-06

CHK BY:

PL

10-24-06

QA:

GZ

10-20-06

MFG:

—
— — — —

REVISION LTR: -

10-20-06

● **Features:**

1. Chip material: AlInGaN (Green)
 and InGaN(Blue)
 and AlGaInP/GaAs (Red)
2. Emitted color : Green and Super Blue
 and Super Red
3. Lens Appearance : Water Clear
4. Low power consumption.
5. High efficiency.
6. Versatile mounting on P.C. Board or panel.
7. Low current requirement.
8. 5mm diameter package
9. This product is RoHS compliant.

● **Package dimensions:**

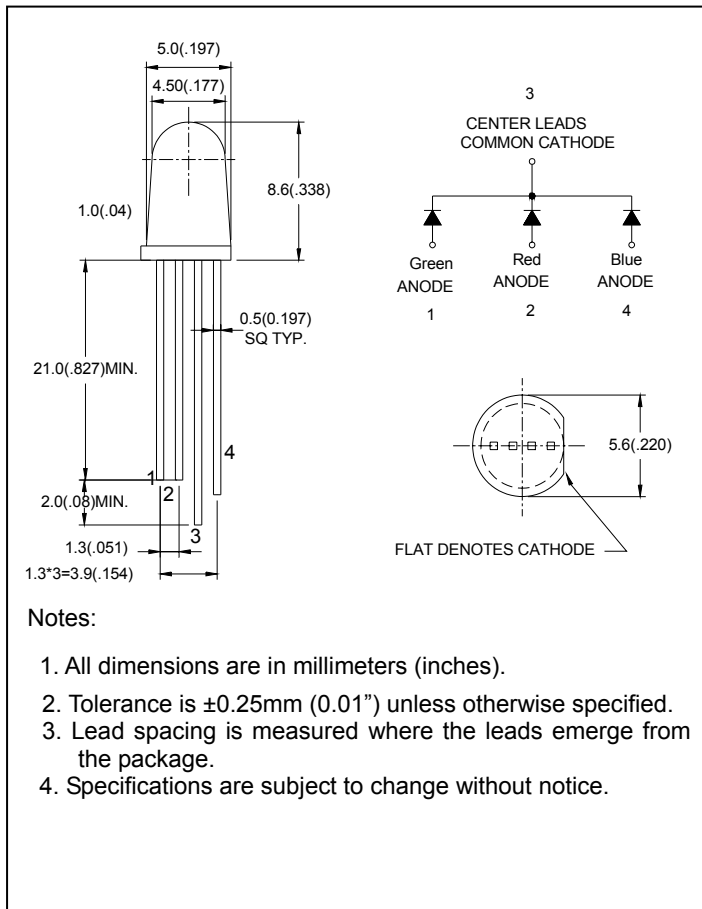

● **Applications:**

1. TV set
2. Monitor
3. Telephone
4. Computer
5. Circuit board

● **Absolute Maximum Ratings(Ta=25°C)**

Parameter	Symbol	Red	Green	Blue	Unit
Power Dissipation	Pd	80	120	120	mW
Forward Current	I _F	30	30	30	mA
Peak Forward Current* ¹	I _{FP}	150	150	150	mA
Reverse Voltage	V _R	5			V
Operating Temperature	Topr	-40°C~80°C			
Storage Temperature	Tstg	-40°C~85°C			
Soldering Temperature	Tsol	260°C (for 5 seconds)			

*¹Condition for I_{FP} is pulse of 1/10 duty and 0.1msec width.

● **Electrical and optical characteristics(Ta=25°C)**

Parameter	Symbol	Condition	Color	Min.	Typ.	Max.	Unit
Forward Voltage	V_F	$I_F=20mA$	Green	-	3.5	4.0	V
			Blue		3.5	4.0	
			Red		2.2	2.6	
Luminous Intensity	I_v	$I_F=20mA$	Green	-	1500	-	mcd
			Blue		1000		
			Red		830		
Reverse Current	I_R	$V_R=5V$	Green	-	-	100	μA
			Blue				
			Red				
Peak Wave Length	λ_p	$I_F=20mA$	Green	-	520	-	nm
			Blue		460		
			Red		630		
Dominant Wave Length	λ_d	$I_F=20mA$	Green	-	525	-	nm
			Blue		467		
			Red		620		
Spectral Line Half-width	$\Delta \lambda$	$I_F=20mA$	Green	-	35	-	nm
			Blue		30		
			Red		17		
Viewing Angle	$2\theta_{1/2}$	$I_F=20mA$	Green	-	20	-	deg
			Blue		20		
			Red		40		
Radiant Intensity		$I_F=20mA$	Green	-	1500	-	$\mu W/sr$
			Blue		1500		
			Red		3500		
Chromaticity Coordinates	X	$I_F=20mA$	Green	-	.175	-	
	Y				.700		
Chromaticity Coordinates	X	$I_F=20mA$	Blue	-	.139	-	
	Y				.060		
Chromaticity Coordinates	X	$I_F=20mA$	Red	-	.692	-	
	Y				.308		

● **Typical Electro-Optical Characteristics Curves**

Fig.1 Relative intensity vs. Wavelength

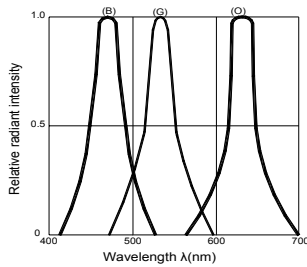

Fig.2 Forward current derating curve vs. Ambient temperature

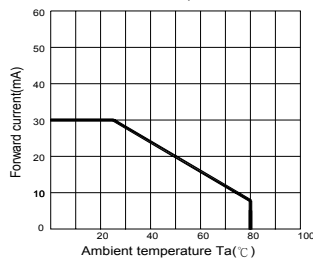

Fig.3 Forward current vs. Forward voltage

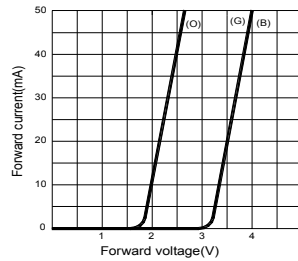

Fig.4 Relative luminous intensity vs. Ambient temperature

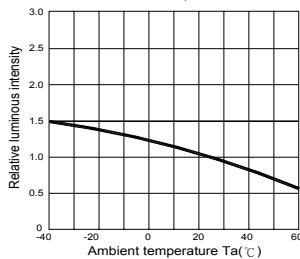

Fig.5 Relative luminous intensity vs. Forward current

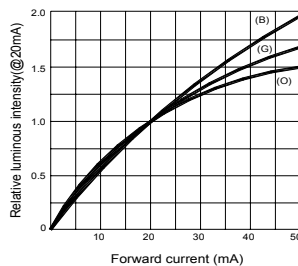

Fig.6 Radiation diagram

