

LD200-0AG-15D

520nm Aqua Green

5mm, Domed, 8.6mm Height
15° viewing angle

DWG BY:
LL / JAG
06-05-06

CHK BY:
PL
06-12-06

QA:
GZ
06-13-06

MFG:
—
—-—-—

REVISION LTR: -
06-05-06

Features:

- High intensity
- 5mm diameter package
- Tinned leads
- Pb-free

Package Dimensions:

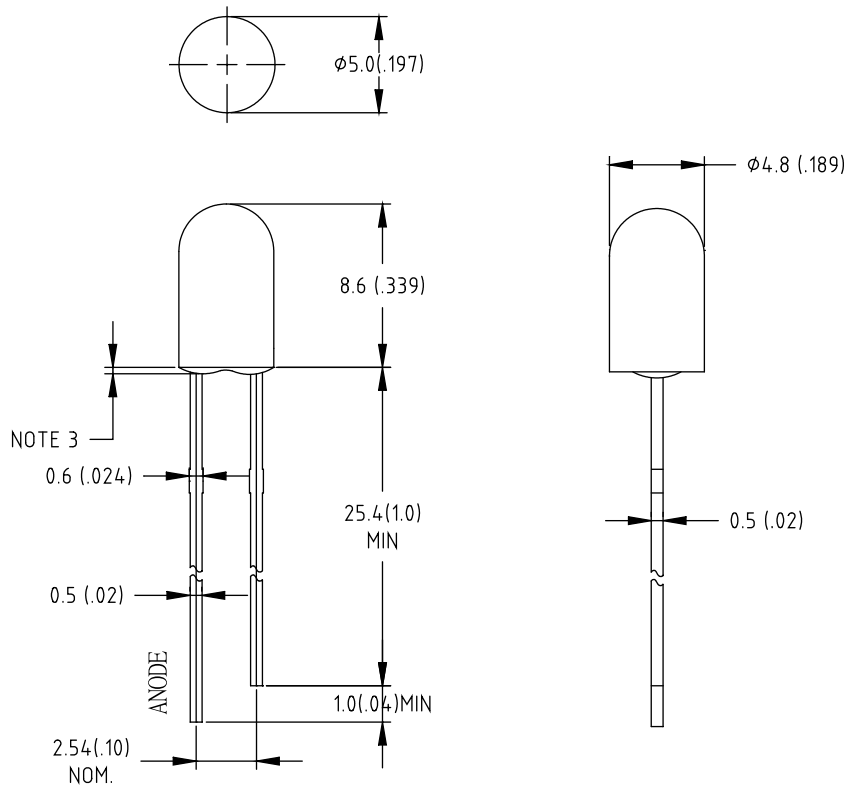

Part No.	Chip Material	Lens Color	Emission Color
LD200-0AG-15D	InGaN	Water Clear	Super Bright True Green

Notes:

1. All dimensions are in millimeters (inches).
2. Tolerance is ± 0.25 mm (.010") unless otherwise noted.
3. Protruded resin under flange is 1.0mm (.04") max.
4. Lead spacing is measured where the leads emerge from the package.
5. Specifications are subject to change without notice.
6. Precautions for ESD: Static electricity and surge can damage the LED. It is recommended to use a wristband or anti-electrostatic glove when handling the LED. All devices, equipment and machinery must be properly grounded.

Absolute Maximum Ratings at Ta=25°C

Parameter	MAX.	Unit
Power Dissipation	80	mW
Peak Forward Current (1/10 Duty Cycle, 0.1ms Pulse Width)	100	mA
Continuous Forward Current	20	mA
Derating Linear From 50°C	0.4	mA/°C
Reverse Voltage	5	V
Electrostatic Discharge (ESD)	800	V
Operating Temperature Range	-30°C to +80°C	
Storage Temperature Range	-40°C to +100°C	
Lead Soldering Temperature [4mm (.157") From Body]	260°C for 5 Seconds	

Electrical Optical Characteristics at Ta=25°C

Parameter	Symbol	Min.	Typ.	Max.	Unit	Test Condition
Luminous Intensity	I _v	16500	28000	---	mcd	I _F =20mA (Note 1)
Viewing Angle	2θ _{1/2}	13	15	18	Deg	(Note 2)
Peak Emission Wavelength	λ _p	518	520	522	nm	I _F =20mA
Dominant Wavelength	λ _d	523	525	527	nm	I _F =20mA (Note 3)
Spectral Line Half-Width	Δλ	---	32	---	nm	I _F =20mA
Forward Voltage	V _F	---	3.0	4.0	V	I _F =20mA
Reverse Current	I _R	---	---	50	μA	V _R =5V
SCP	---	---	0.32	---	cd	I _F =20mA
Lumens	---	---	4.0	---	lm	I _F =20mA
Radiant Intensity	---	---	50000	---	μW/sr	I _F =20mA
Chromaticity Coordinates	x: 0.17 y: 0.73				I _F =20mA	

Notes:

- Luminous intensity is measured with a light sensor and filter combination that approximates the CIE eye-response curve.
- θ_{1/2} is the off-axis angle at which the luminous intensity is half the axial luminous intensity.
- The dominant wavelength (λ_d) is derived from the CIE chromaticity diagram and represents the single wavelength which defines the color of the device.
- Forward voltage measurement allowance is ±0.1V
- Luminous Intensity Measurement Allowance is ± 10%.

Typical Electrical / Optical Characteristics Curves
(25°C Ambient Temperature Unless Otherwise Noted)

Spectral Radiance (Peak @ 520 nm)

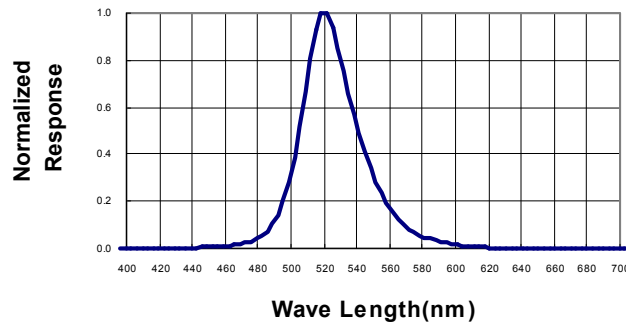

Forward Current vs Forward Voltage

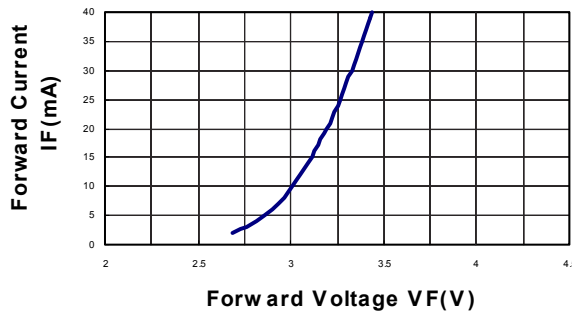

Relative Luminous Intensity vs Forward Current

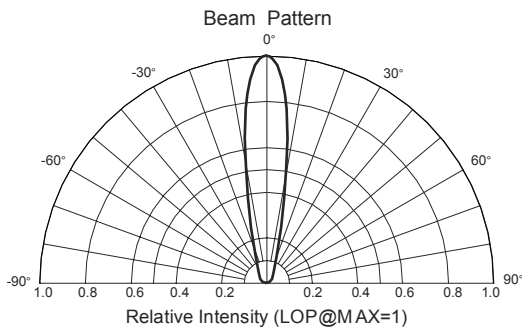
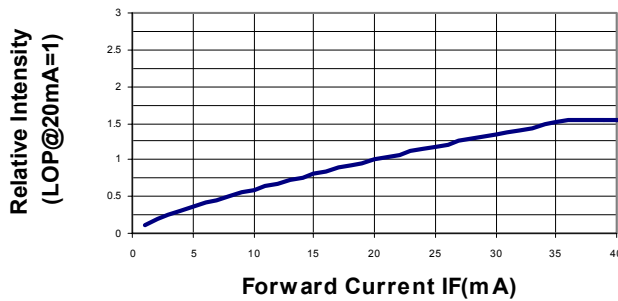

Forward Current Derating Curve

