

L200CWG1KB-30D

Super Green

5mm, Flanged Cylindrical, 8.6mm Height
26° viewing angle

DWG BY:
BL / GP
03-07-07

CHK BY:
PL
03-07-07

QA:
—
— — — —

MFG:
—
— — — —

REVISION LTR: -
03-07-07

● **Features:**

1. Chip material: AlGaInP/GaAs
2. Emitted color : Super Green
3. Lens Appearance : water clear
4. Low power consumption.
5. High efficiency.
6. Versatile mounting on P.C. Board or panel.
7. Low current requirement.
8. T-1 3/4 type package
9. This product is RoHS compliant.

● **Applications:**

1. TV set
2. Monitor
3. Telephone
4. Computer
5. Circuit board

● **Package dimensions:**

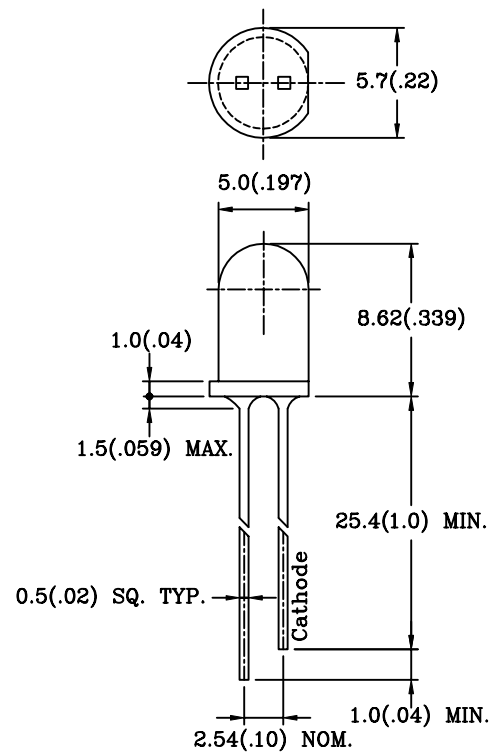

Notes:

1. All dimensions are in millimeters (inches).
2. Tolerance is ± 0.25 mm (0.01") unless otherwise specified.
3. Lead spacing is measured where the leads emerge from the package.
4. Specifications are subject to change without notice.

● **Absolute Maximum Ratings(Ta=25°C)**

Parameter	Symbol	Rating	Unit
Power Dissipation	Pd	110	mW
Forward Current	I _F	30	mA
Peak Forward Current* ¹	I _{FP}	150	mA
Reverse Voltage	V _R	5	V
Operating Temperature	Topr	-40°C~80°C	
Storage Temperature	Tstg	-40°C~85°C	
Soldering Temperature	Tsol	260°C (for 5 seconds)	

*¹ Condition for I_{FP} is pulse of 1/10 duty and 0.1msec width.

● **Electrical and optical characteristics(Ta=25°C)**

Parameter	Symbol	Condition	Min.	Typ.	Max.	Unit
Forward Voltage	V _F	I _F =20mA	-	2.0	2.6	V
Luminous Intensity	I _v	I _F =20mA	-	1000	-	mcd
Reverse Current	I _R	V _R =5V	-	-	100	μA
Peak Wave Length	λ _p	I _F =20mA	-	573	-	nm
Dominant Wave Length	λ _d	I _F =20mA	-	572	-	nm
Spectral Line Half-width	Δλ	I _F =20mA	-	17	-	nm
Viewing Angle	2θ _{1/2}	I _F =20mA	-	26	-	deg
Radiant Intensity		I _F =20mA	-	1700	-	μW/sr
Chromaticity Coordinates	X	I _F =20mA	-	0.46	-	
	Y		-	0.53	-	

● **Typical electro-optical characteristics curves**

