

L120CWY3KH-30D

Super Yellow

3mm, Flanged Cylindrical, 5.3mm Height
40° viewing angle

DWG BY:
LL / GP
10-03-08

CHK BY:
PL
10-03-08

REVISION LTR: -

10-03-08

Features:

- ◆ High intensity
- ◆ Standard 3mm diameter package
- ◆ Tinned leads
- ◆ Pb-free

Package Dimensions:

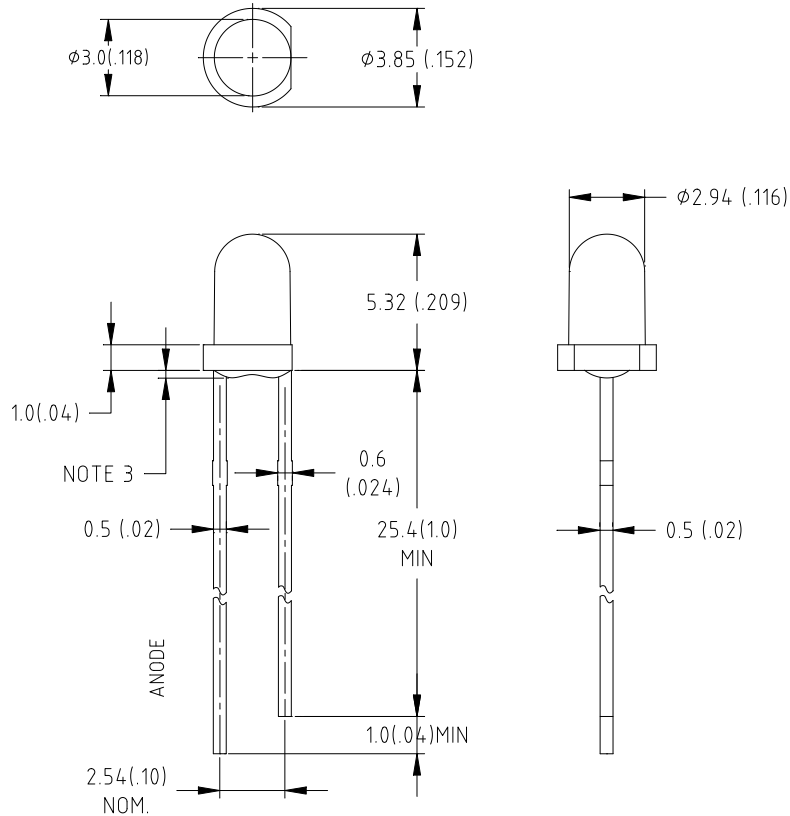

Chip Material	Lens Color	Emission Color
AlGaInP	Water Clear	Super Yellow

Notes:

1. All dimensions are in millimeters (inches).
2. Tolerance is ± 0.25 mm (.010") unless otherwise noted.
3. Protruded resin under flange is 1.0mm (.04") max.
4. Lead spacing is measured where the leads emerge from the package
5. Specifications are subject to change without notice.

Absolute Maximum Ratings at Ta=25°C

Parameter	MAX.	Unit
Power Dissipation	90	mW
Peak Forward Current (1/10 Duty Cycle, 0.1ms Pulse Width)	100	mA
Continuous Forward Current	35	mA
Derating Linear From 50°C	0.4	mA/°C
Reverse Voltage	5	V
Operating Temperature Range	-30°C to +80°C	
Storage Temperature Range	-40°C to +100°C	
Lead Soldering Temperature [4mm(.157") From Body]	280°C for 5 Seconds	

Electrical Optical Characteristics at Ta=25°C

Parameter	Symbol	Min.	Typ.	Max.	Unit	Test Condition
Luminous Intensity	I _v	---	2400	---	mcd	I _F =20mA (Note 1)
Viewing Angle	2θ _{1/2}	---	40	---	Deg	Note 2
Peak Emission Wavelength	λ _p	---	594	---	nm	I _F =20mA
Dominant Wavelength	λ _d	---	591	---	nm	I _F =20mA (Note 3)
Spectral Line Half-Width	λ	---	17	---	nm	I _F =20mA
Forward Voltage	V _F	---	2.0	2.6	V	I _F =20mA
Reverse Current	I _R	---	---	10	μA	V _R =5V
SCP	---	---	---	---	cd	I _F =20mA
Lumens	---	---	---	---	lm	I _F =20mA
Radiant Intensity	---	---	4800	---	mW/sr	I _F =20mA
Chromaticity Coordinates		x: 0.58		y: 0.42		I _F =20mA

Note:

- Luminous intensity is measured with a light sensor and filter combination that approximates the CIE eye-response curve.
- θ_{1/2} is the off-axis angle at which the luminous intensity is half the axial luminous intensity.
- The dominant wavelength (λ_d) is derived from the CIE chromaticity diagram and represents the single wavelength which defines the color of the device.
- Forward voltage measurement allowance is ±0.1V
- Luminous Intensity Measurement Allowance is ±10%

Typical Electrical / Optical Characteristics Curves
 (25°C Ambient Temperature Unless Otherwise Noted)

Spectral Radiance (Peak @ 595nm)

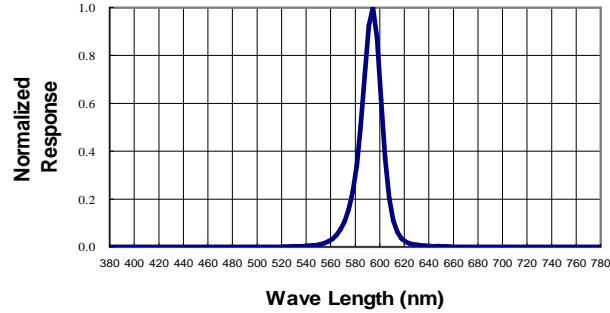

Forward Current vs Forward Voltage

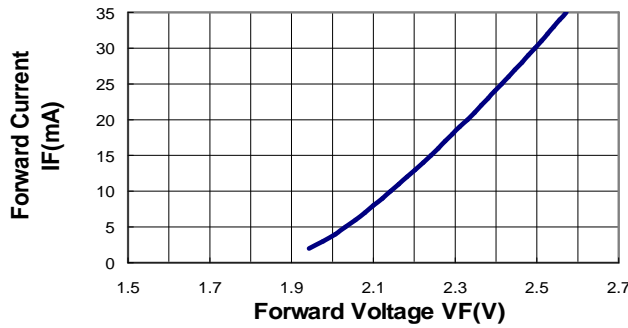

Relative Luminous Intensity vs Forward Current

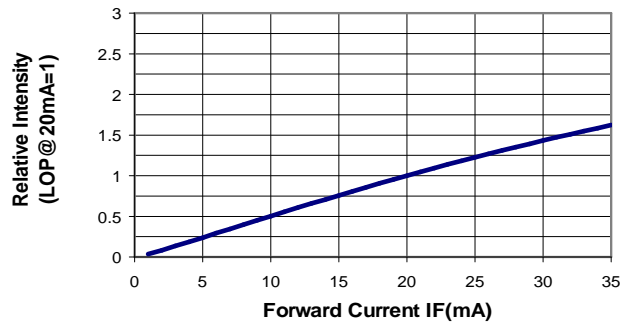

Beam Pattern

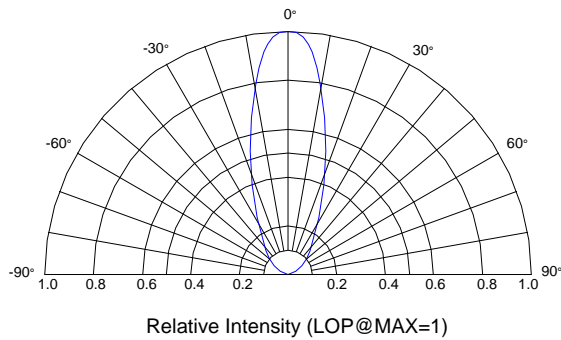

Forward Current Derating Curve

