

LDF200-0UO-22

Super Orange

5mm, Cylindrical, 5.3mm Height
120° viewing angle

DWG BY:
LL / JAG
07-31-06

CHK BY:
PL
10-05-06

QA:
—
10-__-06

MFG:
—
__-__-__

REVISION —

10-04-06

Features:

- High intensity
- 5mm diameter flangeless package
- Tinned leads
- Pb-free

Package Dimensions:

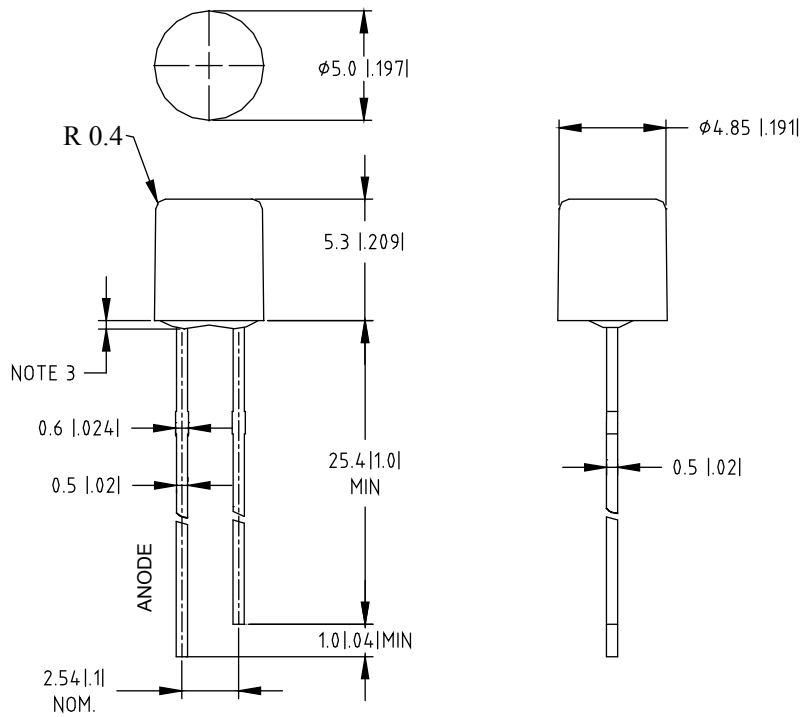

Part No.	Chip Material	Lens Color	Emission Color
LDF200-0UO-22	InGaAlP	Water Clear	Super Bright Orange

Notes:

1. All dimensions are in millimeters (inches).
2. Tolerance is ± 0.25 mm (.010") unless otherwise noted.
3. Protruded resin under flange is 1.0mm (.04") max.
4. Lead spacing is measured where the leads emerge from the package.
5. Specifications are subject to change without notice.

Absolute Maximum Ratings at Ta=25°C

Parameter	MAX.	Unit
Power Dissipation	95	mW
Peak Forward Current (1/10 Duty Cycle, 0.1ms Pulse Width)	100	mA
Continuous Forward Current	35	mA
Derating Linear From 50°C	0.4	mA/°C
Reverse Voltage	5	V
Operating Temperature Range	-30°C to +80°C	
Storage Temperature Range	-40°C to +100°C	
Lead Soldering Temperature [4mm (.157") From Body]	260°C for 5 Seconds	

Electrical Optical Characteristics at Ta=25°C

Parameter	Symbol	Min.	Typ.	Max.	Unit	Test Condition
Luminous Intensity	I _V	200	400	---	mcd	I _F =20mA (Note 1)
Viewing Angle	2θ _{1/2}	---	120	---	Deg	(Note 2)
Peak Emission Wavelength	λ _p	---	610	---	nm	I _F =20mA
Dominant Wavelength	λ _d	---	604	---	nm	I _F =20mA (Note 3)
Spectral Line Half-Width	Δλ	---	20	---	nm	I _F =20mA
Forward Voltage	V _F	---	2.0	2.6	V	I _F =20mA
Reverse Current	I _R	---	---	50	μA	V _R =5V
SCP	---	---	0.12	---	cd	I _F =20mA
Lumens	---	---	1.6	---	lm	I _F =20mA
Radiant Intensity	I _e	---	1200	---	μW/sr	I _F =20mA
Chromaticity Coordinates	x: ~0.64 y: ~0.35					I _F =20mA

Notes:

1. Luminous intensity is measured with a light sensor and filter combination that approximates the CIE eye-response curve.
2. q_{1/2} is the off-axis angle at which the luminous intensity is half the axial luminous intensity.
3. The dominant wavelength (λ_d) is derived from the CIE chromaticity diagram and represents the single wavelength that defines the color of the device.
4. Forward voltage measurement allowance is ±0.1V
5. Luminous Intensity Measurement Allowance is ± 10%.

Typical Electrical / Optical Characteristics Curves
(25°C Ambient Temperature Unless Otherwise Noted)

