

LDF120-XIW-12-LL

Warm White

3mm, Cylindrical, 2.91mm Height
110° viewing angle

DWG BY:
LL / GP
01-18-12

CHK BY:
PL
01-24-12

REVISION LTR: -
01-18-12

Features:

- High intensity
- 3mm diameter no flange package
- Tinned leads
- Pb-free

Package Dimensions:

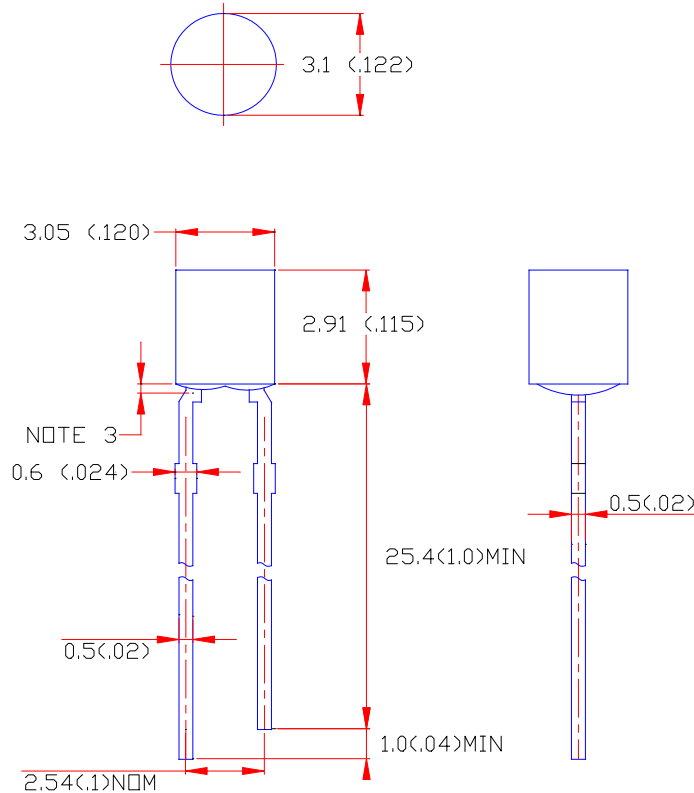

Chip Material	Lens Color	Emission Color
InGaN	Water Clear	Warm White

Notes:

1. All dimensions are in millimeters (inches).
2. Tolerance is $\pm 0.25\text{mm}$ (.010") unless otherwise noted.
3. Protruded resin under flange is 1.0mm (.04") max.
4. Lead spacing is measured where the leads emerge from the package.
5. Specifications are subject to change without notice.
6. Precautions for ESD:
 Static electricity and surge can damages the LED. It is recommended to use a wrist band or anti-electrostatic glove when handling the LED. All devices, equipment and machinery must be properly grounded.

Absolute Maximum Ratings at Ta=25°C

Parameter	MAX.	Unit
Power Dissipation	80	mW
Peak Forward Current (1/10 Duty Cycle, 0.1ms Pulse Width)	100	mA
Continuous Forward Current	20	mA
Derating Linear From 50°C	0.4	mA/°C
Reverse Voltage	5	V
Electrostatic Discharge (ESD)	1000	V
Operating Temperature Range	-20°C to +80°C	
Storage Temperature Range	-30°C to +100°C	
Lead Soldering Temperature [4mm(.157") from Body]	255±5°C for 5 Seconds	
WaveSoldering Temperature	Peak Temperature 245°C~260°C for 10 Seconds	

Electrical Optical Characteristics at Ta=25°C

Parameter	Symbol	Min.	Typ.	Max.	Unit	Test Condition
Luminous Intensity	I _v	1000	1900	---	mcd	I _F =20mA (Note 1)
Viewing Angle	2θ _{1/2}	---	110	---	Deg	(Note 2)
Forward Voltage	V _F	---	3.4	---	V	I _F =20mA
Reverse Current	I _R	---	---	10	μA	V _R =5V
SCP	---	---	---	---	cd	I _F =20mA
Lumens	---	---	---	---	lm	I _F =20mA
Radiant Intensity	---	---	---	---	μW/sr	I _F =20mA
Kelvin	---	2800K	2950K	3200K		I _F =20mA

Color Rank	x	y	x	y	x	y	x	y
LTWW1	0.437	0.4165	0.444	0.4319	0.46	0.436	0.4542	0.4219
LTWW2	0.4299	0.4009	0.437	0.4165	0.4542	0.4219	0.4484	0.4078
LTWW3	0.4147	0.3952	0.4199	0.4111	0.437	0.4165	0.4299	0.4009
LTWW4	0.4258	0.3858	0.4336	0.4023	0.4484	0.4078	0.4417	0.3914
LTWW5	0.4099	0.3801	0.4147	0.3952	0.4336	0.4023	0.4258	0.3858
LTWW6	0.405	0.365	0.4099	0.3801	0.4258	0.3858	0.418	0.3693

Notes:

1. Luminous intensity is measured with a light sensor and filter combination that approximates the CIE eye-response curve.
2. $\theta_{1/2}$ is the off-axis angle at which the luminous intensity is half the axial luminous intensity.
3. Forward voltage measurement allowance is $\pm 0.1V$
4. Luminous Intensity Measurement Allowance is $\pm 10\%$.

**Typical Electrical / Optical Characteristics Curves
 (25°C Ambient Temperature Unless Otherwise Noted)**

