

LTR	REVISION	DATE	APPD
-	RELEASED	12-07-11	

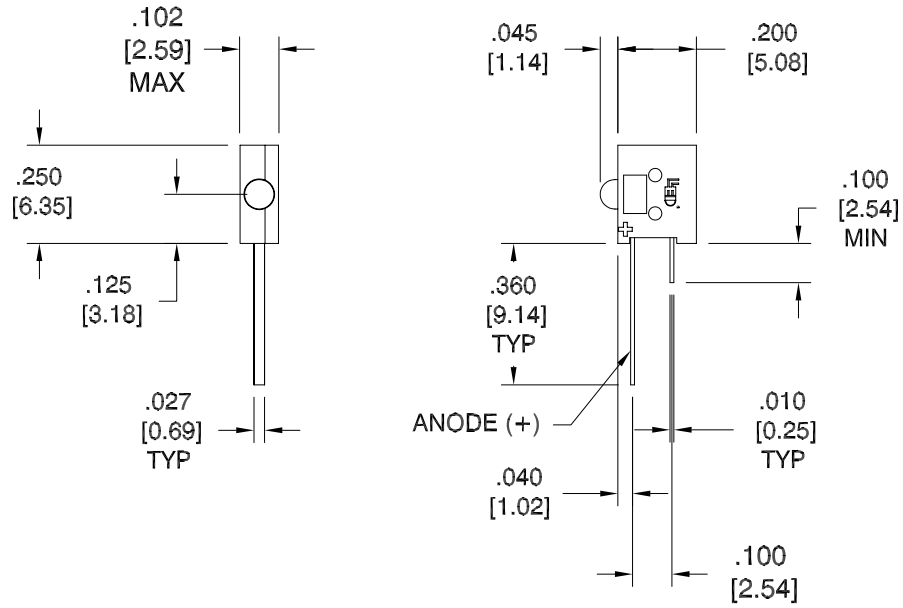

NOTES:

1. ALL DIMENSIONS ARE IN INCHES [MILLIMETERS].
2. LED COLOR: HI-EFF GREEN
3. LENS APPEARANCE: GREEN DIFFUSED
4. BASE MATERIAL: VALOX UL RATING UL94V-1 MIN / 94V-0 PREFERRED
5. BASE COLOR: BLACK



REVISION NOTIFICATION	
<input type="checkbox"/>	PMA
<input type="checkbox"/>	UL
<input type="checkbox"/>	MADE IN USA
<input type="checkbox"/>	CUSTOMER _____
<input type="checkbox"/>	OTHER



-PROPRIETARY-
 This document contains Proprietary information of LEDTRONICS, INC. It may not be copied, used or disclosed for any purpose without the prior express written consent of LEDTRONICS, INC.

.XXX ± .010 TOLERANCE PER ANSI-Y14.5
 .XX ± .025 (UNLESS OTHERWISE STATED)
 ANGLES ± 0°,30'
 FRACT. ± 1/32

TITLE 555M-2303-001					
DWG NO SDPC0669-CUST		SCALE 2:1		SHEET 1 OF 3	
DATE 12-07-11		MFG		R&D BJ	
CODE IDENT NO. 8Z410	DWG BY GP 12-07-11	CHK BY PL 12-08-11	QA	MFG	R&D BJ 12-08-11

Absolute Maximum Ratings at $T_A = 25^\circ\text{C}$

Parameter	Rating	Units
DC Forward Current	30	mA
Peak Forward Current	90	mA
DC Forward Voltage	6	V
Reverse Voltage ($I_R = 100 \mu\text{A}$)	5	V
Transient Forward Current (10 μs Pulse)	500	mA
Operating Temperature Range:	-20 to +85	$^\circ\text{C}$
Storage Temperature Range	-55 to +100	$^\circ\text{C}$
For Thru Hole Devices Wave Soldering Temperature [1.6 mm (0.063 in.) from body]	260 $^\circ\text{C}$ for 5 Seconds	

Electrical/Optical Characteristics, $T_A = 25^\circ\text{C}$

Parameter	Symbol	Min.	Typ.	Max.	Units	Test Conditions
Luminous Intensity ^[1]	I_V	0.8	3		mcd	$V_F = 5.0$ Volts
Forward Current	I_F		4.2	5.0	mA	$V_F = 5.0$ V
Reverse Breakdown Voltage	V_R	5.0	50.0		V	
Included Angle Between Half Intensity Points ^[2]	$2\theta^{1/2}$		90		Deg.	
Peak Wavelength	λ_{PEAK}		562		nm	Measured at Peak
Dominant Wavelength ^[3]	λ_d		565		nm	
Spectral Line Half Width	$\Delta\lambda_{1/2}$		27		nm	
Speed of Response	T_s		500		ns	
Capacitance	C		18		pF	$V_F = 0$; $f = 1$ MHz
Thermal Resistance	$R_{\theta_{\text{J-PIN}}}$		170		$^\circ\text{C}/\text{W}$	Junction-to-Cathode Lead
Luminous Efficacy ^[4]	η_V		595		lm/W	

Notes:

- The luminous intensity for arrays is tested to assure a 2.1 to 1.0 matching between elements. The average luminous intensity for an array determines its light output category bin. Arrays are binned for luminous intensity to allow I_V matching between arrays.
- $\theta^{1/2}$ is the off-axis angle where the luminous intensity is half the on-axis value.
- Dominant wavelength, λ_d , is derived from the CIE Chromaticity Diagram and represents the single wavelength that defines the color of the device.
- Radiant intensity, I_e , in watts/steradian, may be calculated from the equation $I_e = I_V / \eta_V$, where I_V is the luminous intensity in candelas and η_V is the luminous efficacy in lumens/watt.

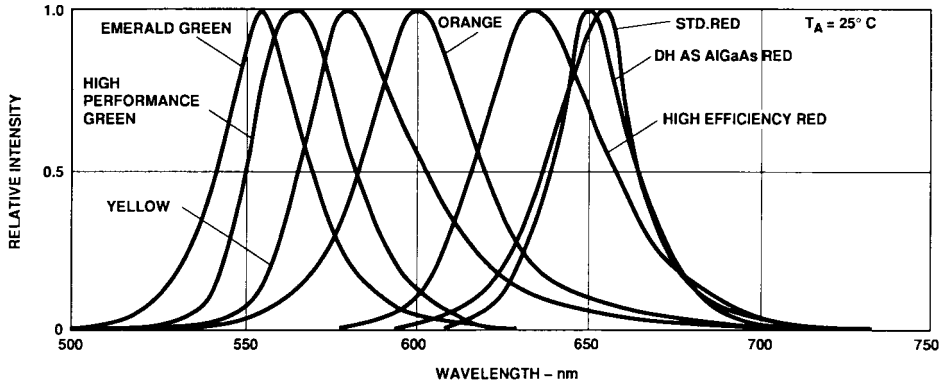

Relative Intensity vs. Wavelength.

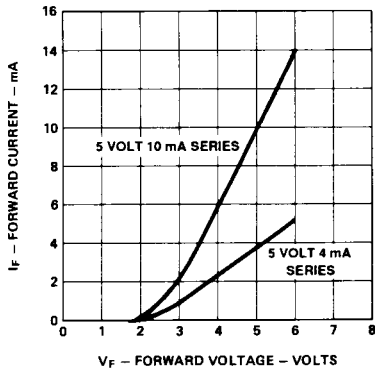

Forward Current vs. Forward Voltage

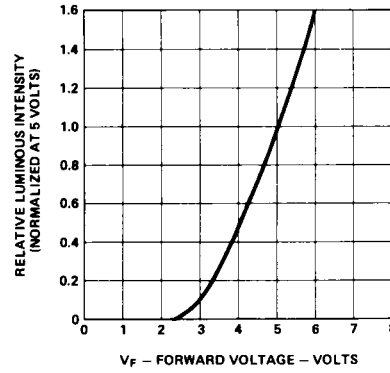

Luminous Intensity vs. Forward Voltage.

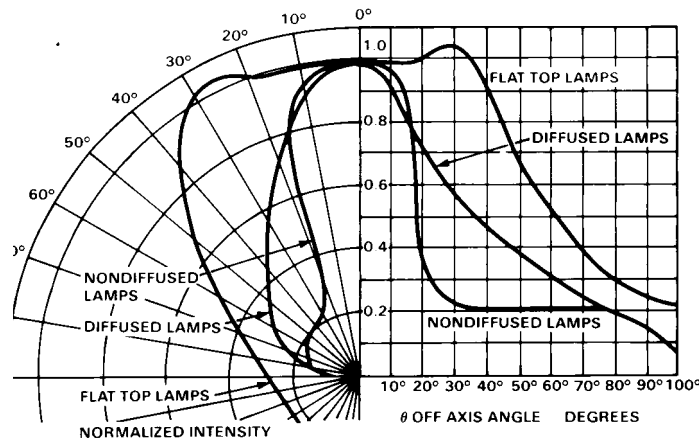

Relative Intensity vs. Angular Displacement.