

LTR	REVISION	DATE	APPD
-	RELEASED (REF. ECR#050311-LUV01)	05-05-11	GP

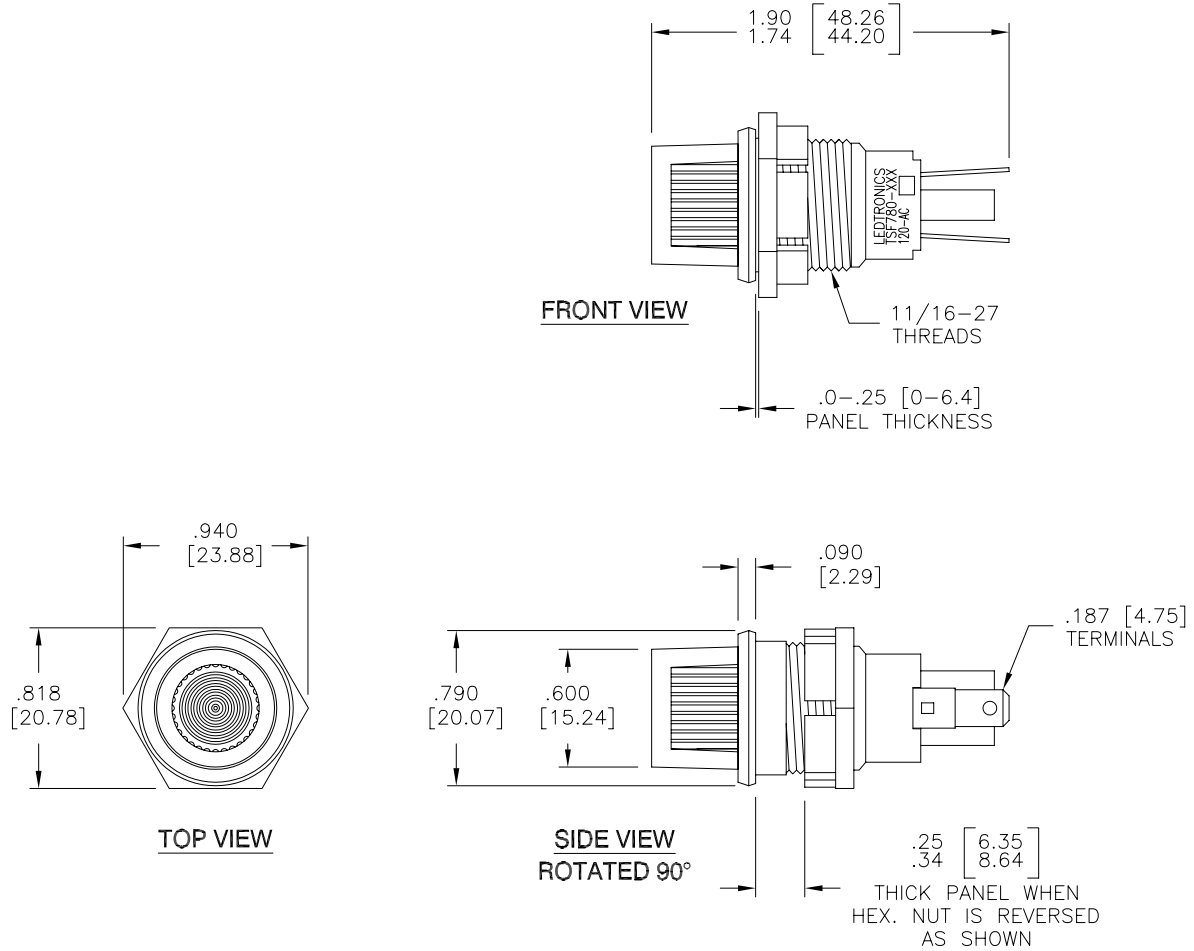

NOTES:

- ALL DIMENSIONS ARE IN INCHES [MILLIMETERS].
- MOUNTING DIAMETER: Ø11/16"
- PARTS WITH (*) ARE "RoHS" CERTIFIED.
- LENS MATERIAL: POLYCARBONATE-UV STABILIZED. (UL94V-2)
- HOLDER MATERIAL:
TERMINALS: NICKEL PLATED BRASS
BODY: BLACK POLYESTER
HEX NUT: POLYESTER



REVISION NOTIFICATION	
<input type="checkbox"/>	PMA
<input type="checkbox"/>	UL
<input type="checkbox"/>	MADE IN USA
<input type="checkbox"/>	CUSTOMER _____
<input type="checkbox"/>	OTHER

TSF780-0ER-120A *	SUPER RED	120VAC	5	83	CLEAR RED	637	120°
TSF780-2AG-120A *	AQUA GREEN	120VAC	5	250	CLEAR GREEN	518	120°
TSF780-2IW-120A	WARM WHITE	120VAC	5	-	WATERCLEAR	3000K	120°
LEDTRONICS PART NO.	COLOR EMITTED	ELECTRICAL TEST					VIEWING ANGLE FULL BEAM WIDTH @ 50% INTENSITY
		INPUT VOLTAGE, V	Read I mA (typ)	Iv, mcd (typ)	LENS TYPE/COLOR	λP nm	

LED[®]
LEDTRONICS,™ INC.
23105 KASHIWA COURT
TORRANCE, CA 90505

-PROPRIETARY-
This document contains Proprietary information of LEDTRONICS,™ INC. It may not be copied, used or disclosed for any purpose without the prior express written consent of LEDTRONICS,™ INC.

.XXX ± .010 TOLERANCE PER ANSI-Y14.5
.XX ± .025 (UNLESS OTHERWISE STATED)
ANGLES ± 0°,30'
FRACT. ± 1/32

TITLE TSF780-XXX-120A							
DWG NO CMMS0314-CUST		SCALE 1:1		SHEET 1 OF 1		DATE 05-05-11	
CODE IDENT NO. 8Z410	DWG BY GP 05-05-11	CHK BY	QA RD 05-05-11	MFG LD 05-06-11	R&D BJ 05-05-11		