

LTR	REVISION	DATE	APPD
B	011013-PL01: UPDATED COLOR EMITTED & COLOR TEMP. ON (SIW)	01-10-13	GP

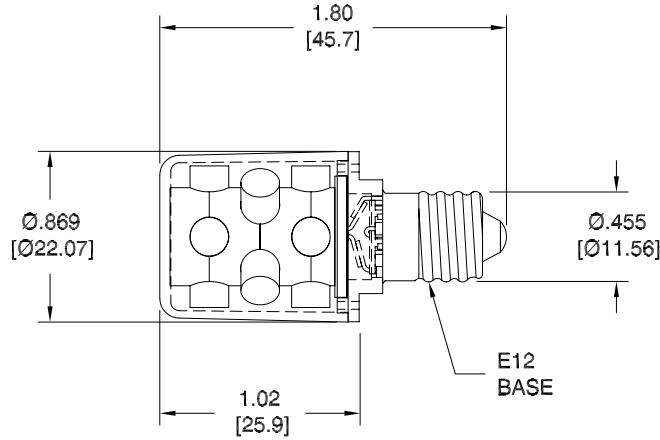

**NOTES:**

1. ALL DIMENSIONS ARE IN INCHES [MILLIMETERS].
2. ALL PARTS WITH (\*) ARE "RoHS" CERTIFIED.
3. LENS MATERIAL: WATERCLEAR, POLYCARBONATE LEXAN 101 (UL94V-2)
4. SLEEVE MATERIAL: CLEAR, POLYCARBONATE LEXAN 141
5. BASE MATERIAL: BRASS, NICKEL PLATED BRASS



REVISION NOTIFICATION	
<input type="checkbox"/>	PMA
<input type="checkbox"/>	UL/ETL
<input type="checkbox"/>	MADE IN USA
<input type="checkbox"/>	CUSTOMER _____
<input type="checkbox"/>	OTHER

**ELECTRO-OPTICAL CHARACTERISTICS**

STL603-01-02 *	ULTRA RED	120VAC	18	1.475 cd	652	-
STL603-03-02	AQUA GREEN	120VAC	18	4.800 cd	518	-
STL603-04-02 *	SUPER YELLOW	120VAC	18	1.400 cd	594	-
STL603-05-02	SUPER BLUE	120VAC	18	-	462	-
STL603-06-02 *	COOL WHITE	120VAC	18	1.920 cd	-	8000K
STL603-SIW-120A	WARM WHITE	120VAC	18	-	-	3000K
LEDTRONICS PART NO.	COLOR EMITTED	INPUT VOLTAGE, V	CURRENT (A)	MAXIMUM CANDELA	λP nm	COLOR TEMP. (Kelvin)

**LED**<sup>®</sup>  
**LEDTRONICS, INC.**<sup>™</sup>  
 23105 KASHIWA COURT  
 TORRANCE, CA 90505

**-PROPRIETARY-**  
 This document contains Proprietary information of LEDTRONICS, INC. It may not be copied, used or disclosed for any purpose without the prior express written consent of LEDTRONICS, INC.

.XXX ± .010 TOLERANCE PER ANSI-Y14.5 (UNLESS OTHERWISE STATED)  
 .XX ± .025  
 ANGLES ± 0°,30'  
 FRACT. ± 1/32

TITLE		<b>STL603-XXX-XXXX</b>				
DWG NO	SCALE	SHEET	DATE			
STL60302-CUST	1:1	1 OF 1	09-30-11			
CODE IDENT NO.	DWG BY	CHK BY	QA	MFG	R&D	
8Z410	GP 09-30-11	PL 01-10-13				