

FEATURES

- 400 MHz Sampling Bandwidth
- 100 MHz Sampling Rate
- Excellent Hold Mode Distortion
 - 66 dB @ 50 MSPS ($f_{IN} = 25$ MHz)
 - 58 dB @ 100 MSPS ($f_{IN} = 50$ MHz)
- Track Mode Slew Rate: 700 V/ μ s
- Low Power: 120 mW Differential Mode
75 mW Single-Ended Mode
- Single +5 V Supply
- Internal +2.5 V Reference

APPLICATIONS

- THA for Differential ADCs
- RF Demodulation Systems
- Test Instrumentation
- Digital Sampling Oscilloscopes

GENERAL DESCRIPTION

The SPT9110 is a single-to-differential track-and-hold amplifier. It can be operated as a single-end THA only or, in full configuration, as a single-to-differential THA. An internal reference provides the common-mode voltage for the single-to-differential output stage. The THA, inverter and reference have separate power supply pins so each can be optionally powered up and used.

This device provides an analog designer with a low cost single-to-differential THA amplifier for interfacing differential and single-ended ADCs.

The SPT9110 is offered in a 28-lead SOIC package in the industrial temperature range.

BLOCK DIAGRAM

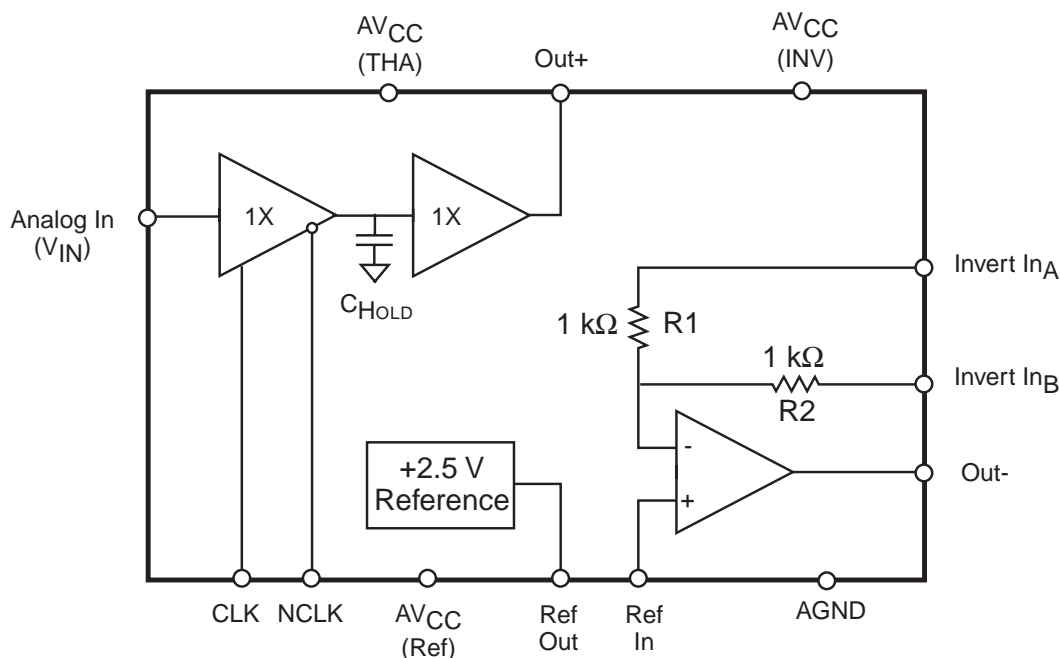

ABSOLUTE MAXIMUM RATING (Beyond which damage may occur)¹

Supply Voltages

AV_{CC} Supplies -0.5 to +6 V

Output Currents²

Continuous Output Current ±15 mA

Input Voltages

Analog Input Voltage -0.5 to +6 V

CLK, NCLK Input -0.5 to +6 V

Ref In -0.5 to +6 V

Temperature

Operating Temperature -40 to +85 °C

Junction Temperature +150 °C

Lead, Soldering (10 seconds) +220 °C

Storage -65 to +150 °C

Note 1: Operation at any Absolute Maximum Ratings is not implied. See Electrical Specifications for proper nominal applied conditions in typical application.

Note 2: Outputs are short circuit protected.

ELECTRICAL SPECIFICATIONS

AV_{CC} = +5.0 V, AGND = 0.0 V, Output Load = 1 kΩ and 10 pF, V_{IN} = 2.0 V_{p-p}, Internal Reference, unless otherwise specified.

PARAMETERS	TEST CONDITIONS	TEST LEVEL	SPT9110			UNITS
			MIN	TYP	MAX	
DC Performance						
Gain ΔV _{IN} = 2.0 V _{p-p}	+25 °C	I	0.95	0.97	0.99	V/V
		V		0.96		V/V
Single Ended Out	Full Temperature	I	1.80	1.93	2.00	V/V
		V		1.92		V/V
Differential Out	+25 °C	I	-100	±50	+100	mV
		V		55		mV
Offset V _{IN} = +2.5 V	+25 °C, Ref In=Out+ CM	I	-15	±5	±15	mV
		V		10		mV
Out+	Full Temperature	IV	Full Temperature	±1	±10	mA
		V		1		kΩ
Analog Input/Output						
Output Voltage Range	Full Temperature	VI	1.5		3.5	V
Input Capacitance	+25 °C	V		5		pF
Input Resistance	+25 °C	I	100	140		kΩ
Reference Voltage Output		I	2.35	2.45	2.55	V
Reference Output Current ³	+25 °C	V		±100		μA
Reference Voltage Tempco	Full Temperature	V		75		ppm/°C
Clock Inputs						
Input Type/Logic Family		V	Differential PECL			
Input Bias Current	+25 °C	I		2	10	μA
Input Low Voltage (Differential)	+25 °C	I		3.3	3.5	V
Input High Voltage (differential)	+25 °C	I	3.9	4.1		V

¹Differential offset is specified with Ref In equal to the common mode output voltage of OUT+ and so includes the offset error of the inverter only.

²This part is intended to drive a high impedance load. AC performance is degraded at ±10 mA. See the Typical Performance Graphs.

³Ref Out has a typical output impedance of 1 kΩ and should be buffered for driving loads other than Ref In.

ELECTRICAL SPECIFICATIONS

$AV_{CC} = +5.0\text{ V}$, $AGND = 0.0\text{ V}$, Output Load = $1\text{ k}\Omega$ and 10 pF , $V_{IN} = 2.0\text{ V}_{p-p}$, Internal Reference, unless otherwise specified.

PARAMETERS	TEST CONDITIONS	TEST LEVEL	SPT9110			UNITS
			MIN	TYP	MAX	
Track Mode Dynamics						
Bandwidth (-3 dB)	+25 °C	V		220		MHz
Single Ended Out						
Differential Out		V		140		MHz
Slew Rate 2.0 Vp-p Output Step						
Single Ended Out	+25 °C	IV		580		V/ μ s
Differential Out ⁷						
		IV		800		V/ μ s
Input RMS Spectral Noise						
	Single Ended	V		3.5		nV/ $\sqrt{\text{Hz}}$
	Differential	V		13.0		nV/ $\sqrt{\text{Hz}}$
Track-to-Hold Switching						
Aperture Delay	+25 °C	V		250		ps
Aperture Jitter	+25 °C	V		<1		ps rms
Pedestal Offset	+25 °C	IV		± 12		mV
	Full Temperature	V		± 12		mV
Hold Mode Dynamics⁴ ($V_{IN} = 1\text{ V}_{p-p}$)						
Worst Harmonic						
5 MHz, 50 MSPS, Single-Ended	$T_A = +25\text{ °C}$	IV	-64	-68		dB
	$T_A = -40\text{ °C to }+85\text{ °C}$	V		-64		dB
Worst Harmonic						
5 MHz, 50 MSPS, Differential	$T_A = +25\text{ °C}$	IV	-61	-65		dB
	$T_A = -40\text{ °C to }+85\text{ °C}$	V		-63		dB
Worst Harmonic						
25 MHz, 50 MSPS, Single-Ended	$T_A = +25\text{ °C}$	V		-66		dB
	$T_A = -40\text{ °C to }+85\text{ °C}$	V		-63		dB
Worst Harmonic						
25 MHz, 50 MSPS, Differential	$T_A = +25\text{ °C}$	V		-64		dB
	$T_A = -40\text{ °C to }+85\text{ °C}$	V		-60		dB
Worst Harmonic						
50 MHz, 100 MSPS, Single-Ended	$T_A = +25\text{ °C}$	IV	-54	-58		dB
	$T_A = -40\text{ °C to }+85\text{ °C}$	V		-54		dB
Worst Harmonic						
50 MHz, 100 MSPS, Differential	$T_A = +25\text{ °C}$	IV	-50	-54		dB
	$T_A = -40\text{ °C to }+85\text{ °C}$	V		-50		dB
Sampling Bandwidth ⁵ (-3 dB)	+25 °C	V		400		MHz
$V_{IN} = 2.0\text{ V}_{p-p}$						
Hold Noise ⁶ (RMS)	+25 °C	V		$300 \times t_H$		mV/s
Droop Rate, $V_{IN} = +2.5\text{ V}$	+25 °C	IV		± 40		mV/ μ s
	Full Temperature	IV		± 80		mV/ μ s
Feedthrough Rejection (50 MHz)	Full Temperature	V		-65		dB
$V_{IN} = 2\text{ V}_{p-p}$						

- For hold times longer than 50 ns, the input common mode voltage may affect the hold mode distortion. (This is due to nonlinear droop that varies with VCM.) For optimal performance, CADEKA recommends that the held output signal be used within 50 ns of the application of the hold signal.
- Sampling bandwidth is defined as the -3 dB frequency response of the input sampler to the hold capacitor when operating in the sampling mode. It is greater than tracking bandwidth because it does not include the bandwidth of the output amplifier.
- Hold mode noise is proportional to the length of time a signal is held. This value must be combined with the track mode noise to obtain total noise.
- Optimized for hold mode performance and low power.

ELECTRICAL SPECIFICATIONS

$AV_{CC} = +5.0\text{ V}$, $AGND = 0.0\text{ V}$, $R_{Load} = 1\text{ k}\Omega$ and 10 pF , $V_{IN} = 2.0\text{ V}_{p-p}$, Internal Reference, unless otherwise specified.

PARAMETERS	TEST CONDITIONS	TEST LEVEL	SPT9110			UNITS
			MIN	TYP	MAX	
Hold-to-Track Switching ⁸						
Acquisition Time to 0.1% 1 V Output Step	+25 °C	V		3.5		ns
Acquisition Time to 0.025% 1 V Output Step	+25 °C	V		4.0		ns
Power Supplies						
Supply Voltage		IV	4.75	5	5.25	V
Supply Current						
Single Ended Output Mode ⁹		I		15	20	mA
Differential Output Mode		I		24	30	mA
Power Dissipation						
Single Ended Output Mode ⁹		I		75	100	mW
Differential Output Mode		I		120	150	mW
Power Supply Rejection Ratio	+25 °C	V		44		dB
Single-Ended Output	$\Delta V_{CC} = 0.5\text{ V}_{P-P}$					

8. Measured at the hold capacitor.

9. Inverter powered down.

TEST LEVEL CODES

All electrical characteristics are subject to the following conditions: All parameters having min/max specifications are guaranteed. The Test Level column indicates the specific device testing actually performed during production and Quality Assurance inspection. Any blank section in the data column indicates that the specification is not tested at the specified condition.

TEST LEVEL

I
II
III
IV
V
VI

TEST PROCEDURE

100% production tested at the specified temperature.
100% production tested at $T_A = +25\text{ °C}$, and sample tested at the specified temperatures.
QA sample tested only at the specified temperatures.
Parameter is guaranteed (but not tested) by design and characterization data.
Parameter is a typical value for information purposes only.
100% production tested at $T_A = +25\text{ °C}$. Parameter is guaranteed over specified temperature range.

TIMING SPECIFICATION DEFINITIONS

ACQUISITION TIME

This is the time it takes the SPT9110 to acquire the analog signal at the internal hold capacitor when it makes a transition from hold mode to track mode. (See figure 1.) The acquisition time is measured from the 50% input clock transition point to the point when the signal is within a specified error band at the internal hold capacitor (ahead of the output amplifier). It does not include the delay and settling time of the output amplifier. Because the signal is internally acquired and settled at the hold capacitor before the output voltage has settled, the sampler can be put in hold mode before the output has settled.

TRACK-TO-HOLD SETTLING TIME

The time required for the output to settle to within 4 mV of its final value.

APERTURE DELAY

The aperture delay time is the interval between the leading edge transition of the clock input and the instant when the input signal was equal to the held value. It is the difference in time between the digital hold switch delay and the analog signal propagation time.

Figure 1 - Timing Diagram

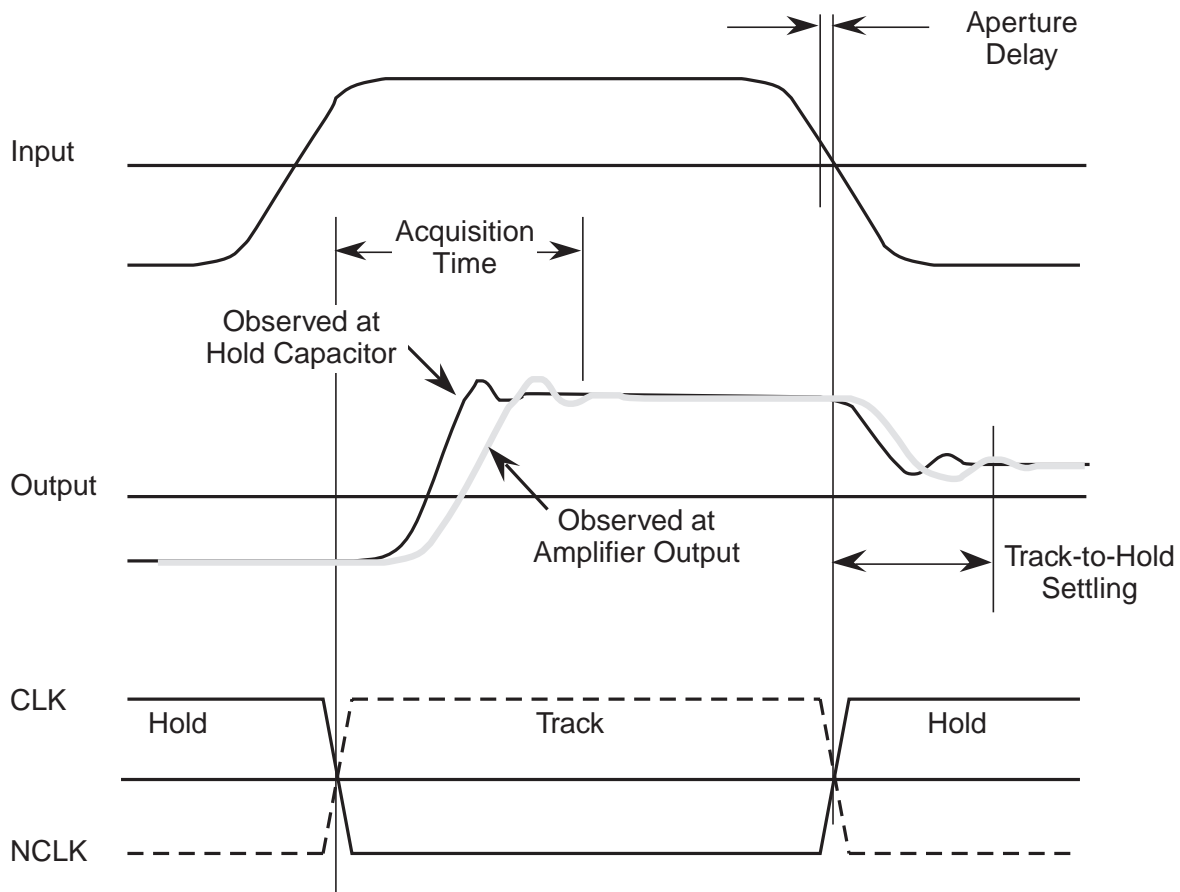
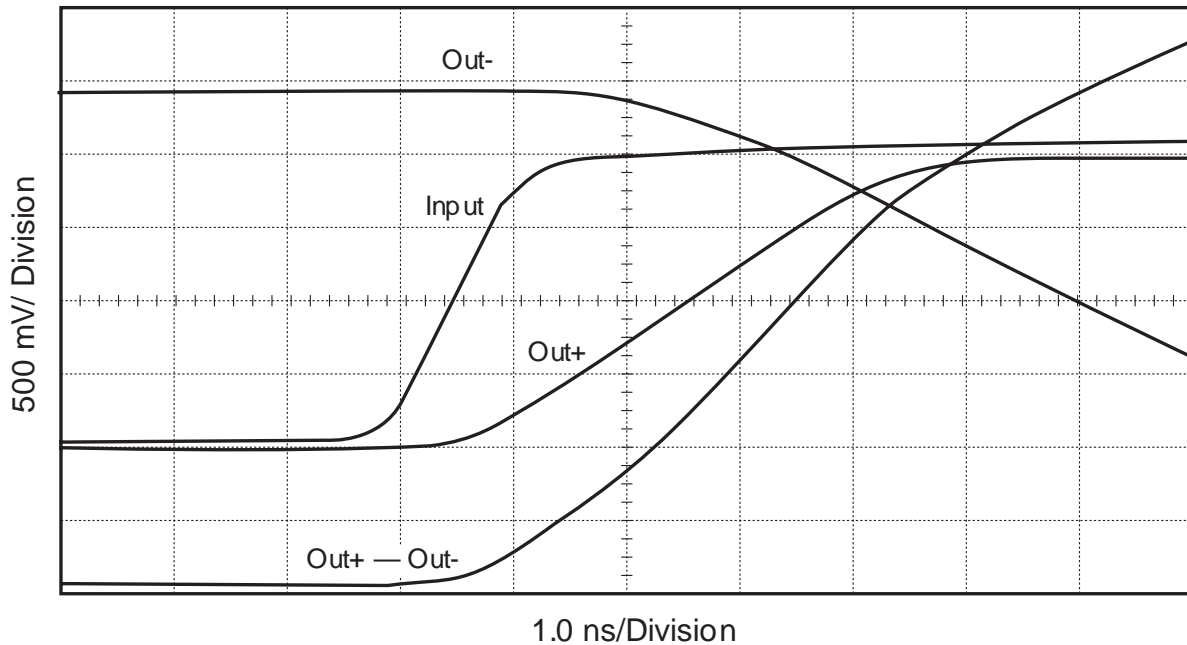

Figure 2 - Typical Output Response to Step Input



GENERAL DESCRIPTION

The SPT9110 is a low cost 100 MSPS track-and-hold amplifier with single ended (75 mW) or differential output (120 mW). It consists of three components. The first is a single-ended track-and-hold amplifier (THA) with a 1.5 to 3.5 V input range and PECL clock inputs. The second is an inverting op amp with gain of -1 to provide the differential output (OUT-). The third component is a 2.5 V bandgap reference for the inverter.

PARTITIONED POWER SUPPLY MANAGEMENT

Three separate +5 V supply connections power the THA, inverting the op amp and bandgap reference. Unused components can be powered off to minimize power dissipation.

The single-ended mode requires use of only the THA and output on the OUT+ pin. In this mode the reference and inverter may be powered down.

The differential mode requires use of all three components (unless an external reference is supplied). The output is measured between OUT+ and OUT- in this mode.

Figure 3 - Typical Interface Circuit (Single-Ended Operational Design)

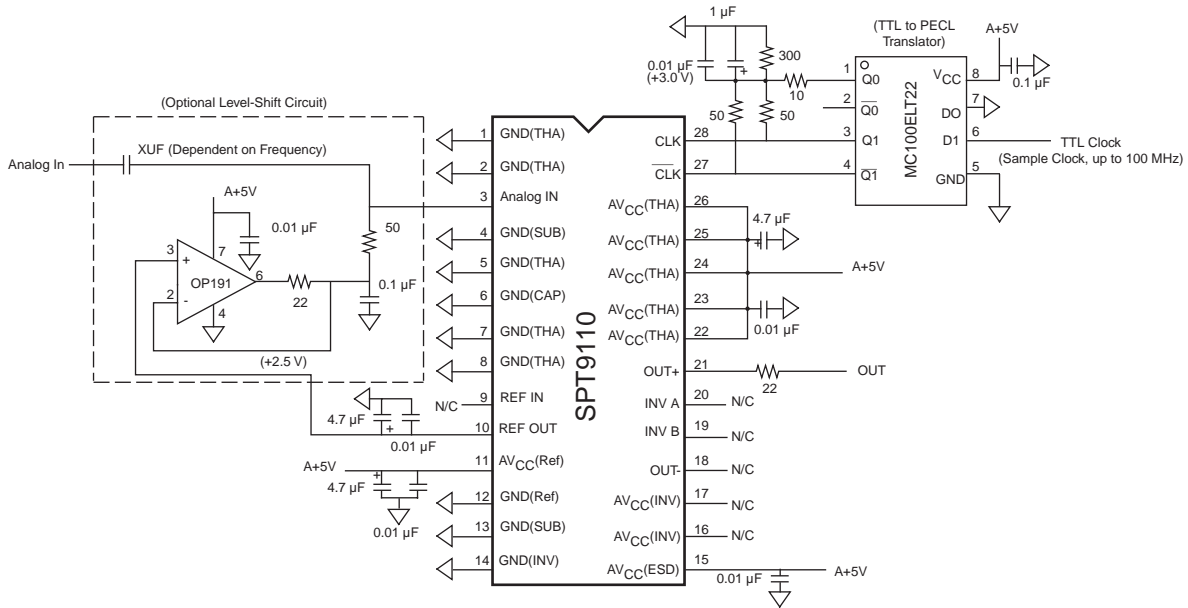

Notes:

1. Input signal is typically at a +2.5 V offset. The optional level-shift circuit may be eliminated if driving from a source that already provides for this offset.
2. The device may be operated from -5 V supply on GND pins and 0 V on AV_{CC} pins. All input and output pins will be shifted by -5 V. The use of an ECL level may be used to drive the clock inputs.
3. V_{CC} (ESD) is the high voltage for the ESD protection diodes and must be connected in all applications. NOTE: It should be tied to V_{CC} (THA), not to V_{CC} (INV).

Figure 4 - Typical Interface Circuit (Differential Operational Design)

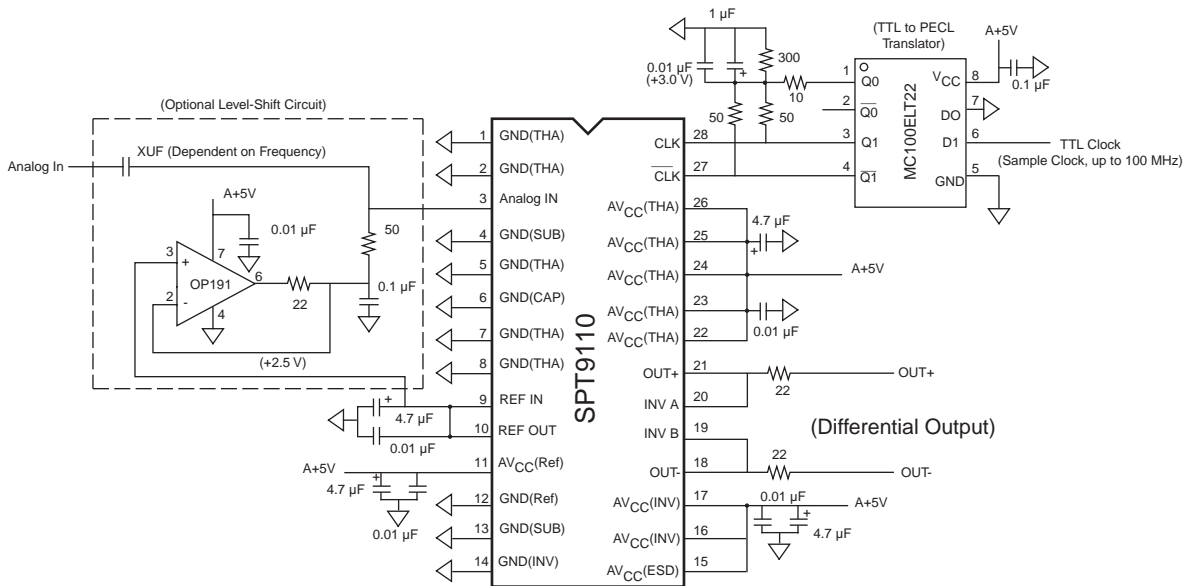

Notes:

1. Input signal is typically at a +2.5 V offset. The optional level-shift circuit may be eliminated if driving from a source that already provides for this offset.
2. The device may be operated from -5 V supply on GND pins and 0 V on AV_{CC} pins. All input and output pins will be shifted by -5 V. The use of an ECL level may be used to drive the clock inputs.
3. V_{CC} (ESD) is the high voltage for the ESD protection diodes and must be connected in all applications. NOTE: It should be tied to V_{CC} (THA), not to V_{CC} (INV).

TYPICAL PERFORMANCE CHARACTERISTICS

Single-Ended (OUT+) Hold Mode Distortion vs. Sample Rate

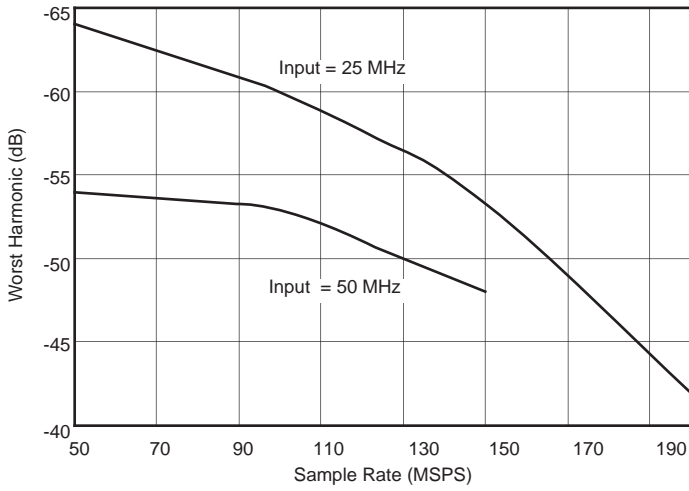

Track Mode Bandwidth

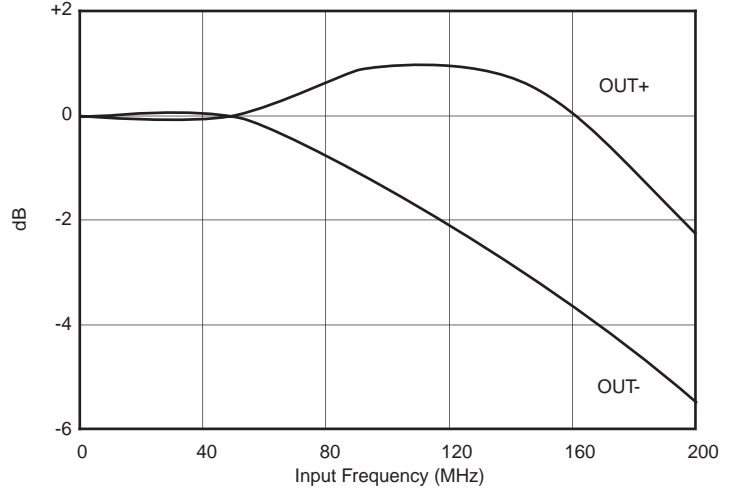

Reference Output Voltage vs. Temperature

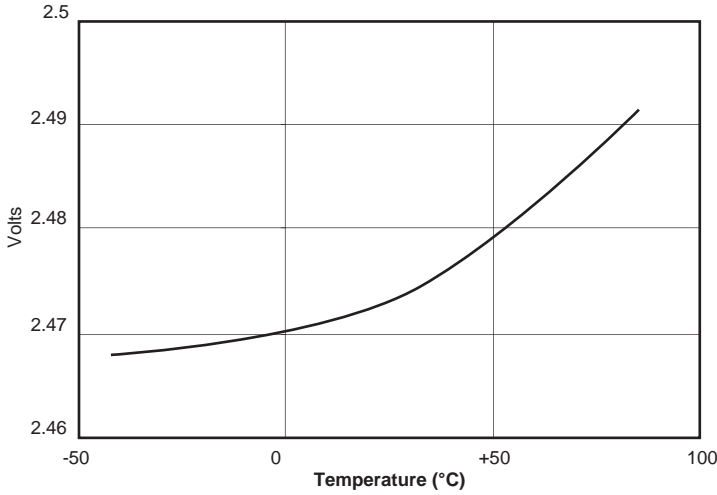

Slew Rate vs. Temperature
 $V_{OUT} = 2 V_{P-P}$

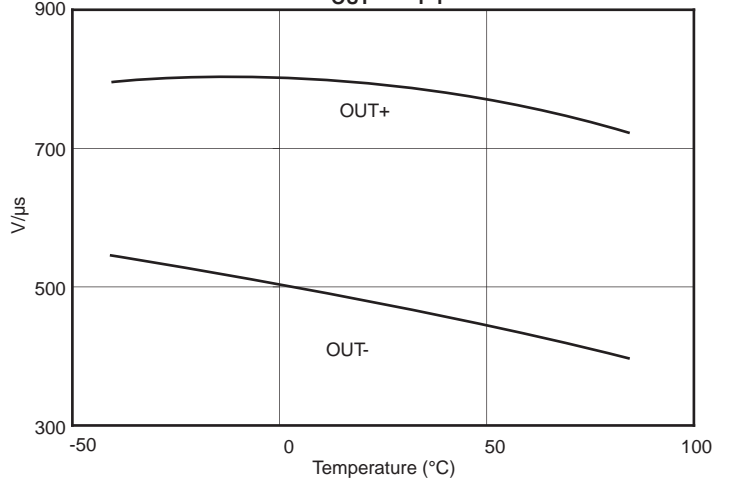

Differential Track Mode Distortion vs. Input Frequency
 $V_{IN} = 1 V_{P-P}$

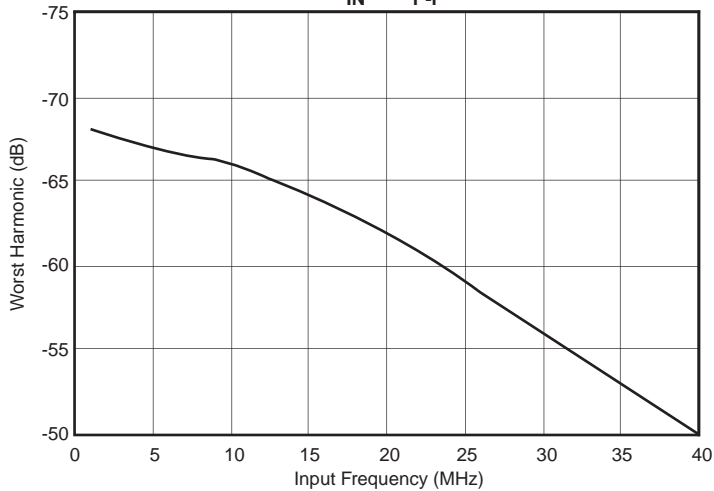

Single Ended Track Mode Distortion vs. Input Frequency
 $V_{IN} = 1 V_{P-P}$

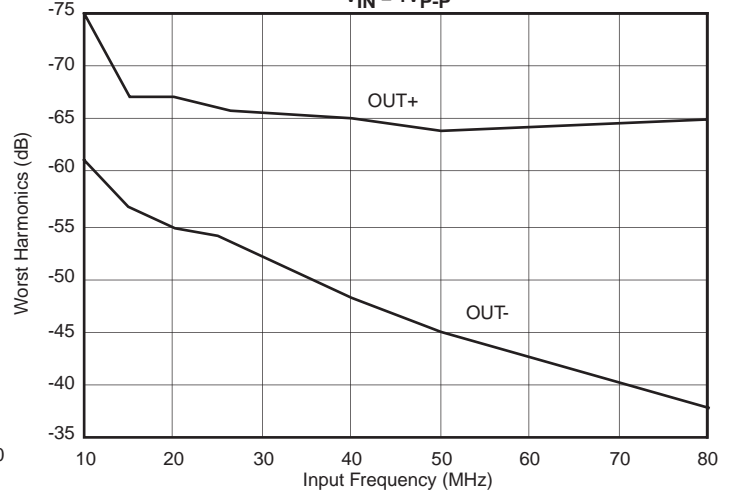

TYPICAL PERFORMANCE CHARACTERISTICS

Track Mode Distortion vs. AC Coupled Resistive Load
 $f_{IN} = 40 \text{ MHz}$, 1 V_{p-p} , $C_{Load} = 10 \text{ pF}$

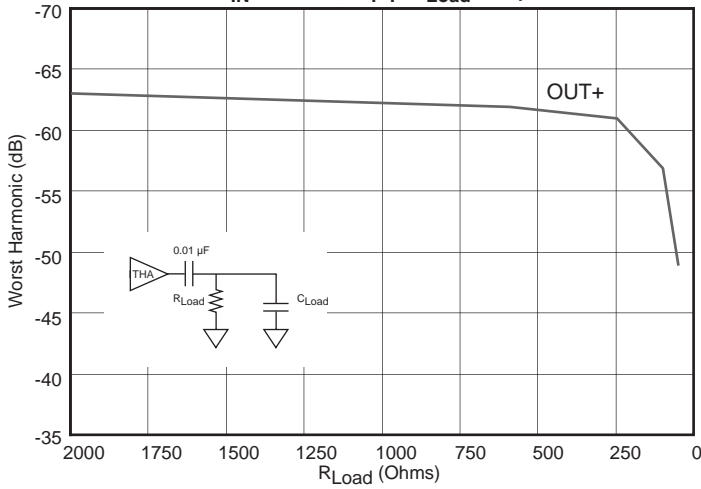

Hold Mode Distortion vs. Temperature
 $f_{IN} = 5 \text{ MHz}$, $f_S = 50 \text{ MSPS}$

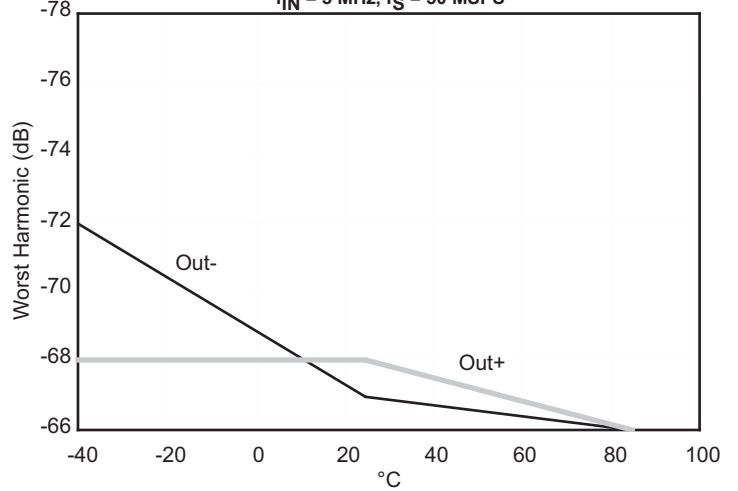

Hold Mode Distortion vs. Temperature
 $f_{IN} = 25 \text{ MHz}$, $f_S = 50 \text{ MSPS}$

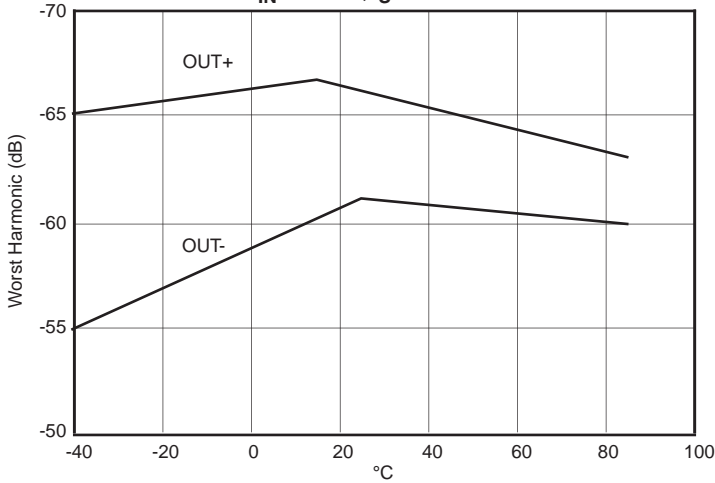

Hold Mode Distortion vs. Temperature
 $f_{IN} = 50 \text{ MHz}$, $f_S = 100 \text{ MSPS}$

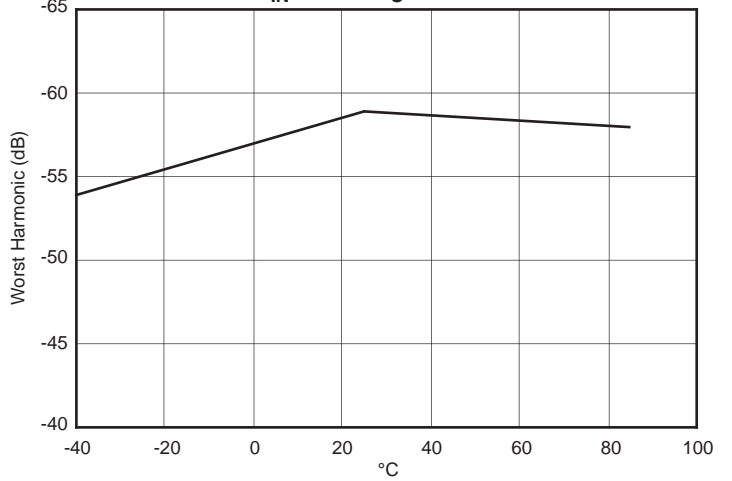

DC Parameters vs. Temperature
 $(V_{IN} = 2.5 \text{ V})$

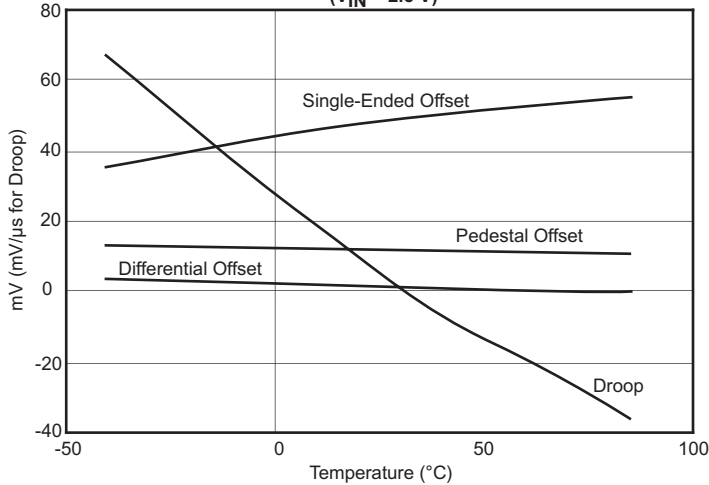

PACKAGE OUTLINE

28-LEAD SOIC

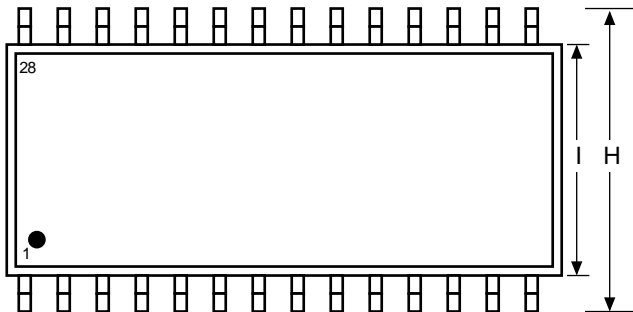

SYMBOL	INCHES		MILLIMETERS	
	MIN	MAX	MIN	MAX
A	0.696	0.712	17.68	18.08
B	0.004	0.012	0.10	0.30
C		.050 typ	0.00	1.27
D	0.014	0.019	0.36	0.48
E	0.009	0.012	0.23	0.30
F	0.080	0.100	2.03	2.54
G	0.016	0.050	0.41	1.27
H	0.394	0.419	10.01	10.64
I	0.291	0.299	7.39	7.59

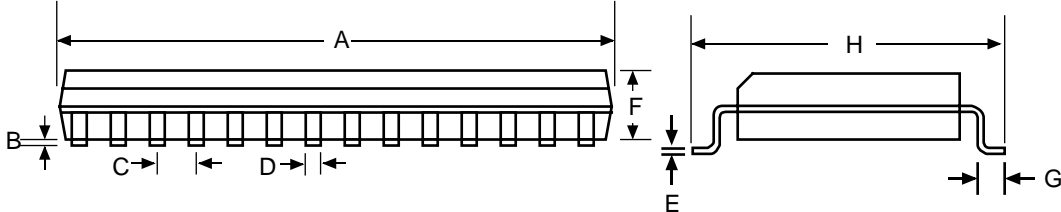

PIN ASSIGNMENTS

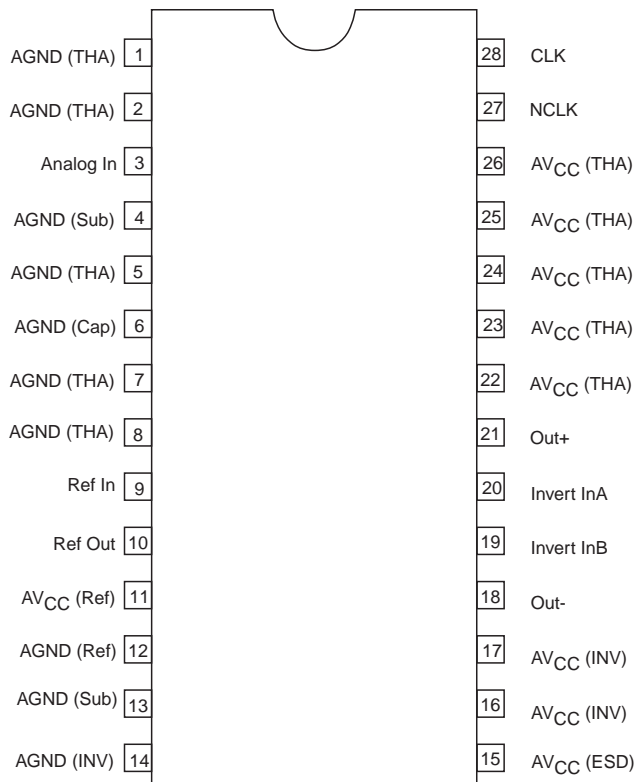

PIN FUNCTIONS

Name	Function
Analog In	Single-ended analog input to the THA
Invert InA	Inverting input A to inverting amplifier resistor R1
Invert InB	Inverting input B to inverting amplifier resistor R2
Out+	Single-ended output of the THA
Out-	Output from the inverting amplifier
CLK	Noninverting differential PECL clock input
NCLK	Inverting differential PECL clock input
Ref In	Common-mode reference for the inverting amplifier
Ref Out	Internal +2.5 V reference output
AVCC (THA)	Track-and-hold analog +5 V supply
AVCC (INV)	Inverter +5 V supply
AVCC (Ref)	Internal reference +5 V supply
AVCC (ESD)	+5 V supply for ESD protection diodes
AGND (THA)	Track-and-hold analog ground
AGND (Cap)	Hold capacitor analog ground
AGND (Sub)	Substrate analog ground
AGND (INV)	INVERTER analog ground
AGND (Ref)	Internal reference analog ground

ORDERING INFORMATION

PART NUMBER	TEMPERATURE RANGE	PACKAGE TYPE
SPT9110SIS	-40 to +85 °C	28L SOIC

For additional information regarding our products, please visit CADEKA at: cadeka.com

CADEKA Headquarters Loveland, Colorado
T: 970.663.5452
T: 877.663.5452 (toll free)

CADEKA, the CADEKA logo design, COMLINEAR and the COMLINEAR logo design are trademarks or registered trademarks of CADEKA Microcircuits LLC. All other brand and product names may be trademarks of their respective companies.

CADEKA reserves the right to make changes to any products and services herein at any time without notice. CADEKA does not assume any responsibility or liability arising out of the application or use of any product or service described herein, except as expressly agreed to in writing by CADEKA; nor does the purchase, lease, or use of a product or service from CADEKA convey a license under any patent rights, copyrights, trademark rights, or any other of the intellectual property rights of CADEKA or of third parties.

Copyright ©2007-2008 by CADEKA Microcircuits LLC. All rights reserved.

