

FAST, COMPLETE 12-BIT μ P COMPATIBLE A/D CONVERTER WITH SAMPLE/HOLD

FEATURES

- Improved High-Performance Version of the HADC574Z
- Complete 12-Bit A/D Converter with Sample/Hold, Reference and Clock
- Low Power Dissipation (120 mW Max)
- 12-Bit Linearity (Over Temp)
- 15 μ s Max Conversion Time
- Single +5 V Supply
- Full Bipolar and Unipolar Input Range

GENERAL DESCRIPTION

The SPT674 is a complete, 12-bit successive approximation A/D converter manufactured in CMOS technology. The device is an improved version of the HADC574Z. Included on chip are an internal reference, clock, and a sample-and-hold. The S/H is an additional feature not available on similar devices.

The SPT674 features 15 μ s (max) conversion time of 10 or 20 V input signals. Also, a three-state output buffer is added for direct interface to an 8, 12, or 16-bit μ P bus.

APPLICATIONS

- Data Acquisition Systems
- 8 or 12-Bit μ P Input Functions
- Process Control Systems
- Test and Scientific Instruments
- Personal Computer Interface

The SPT674 has standard bipolar and unipolar input ranges of 10 V and 20 V that are controlled by a bipolar offset pin and laser trimmed for specified linearity, gain and offset accuracy.

The power supply is +5 V. The device also has an optional mode control voltage which may be used depending on the application. With a maximum dissipation of 120 mW at the specified voltages, power consumption is about five times lower than that of currently available devices.

The SPT674 is available in a 28-lead ceramic sidebraced DIP package in the commercial temperature range.

BLOCK DIAGRAM

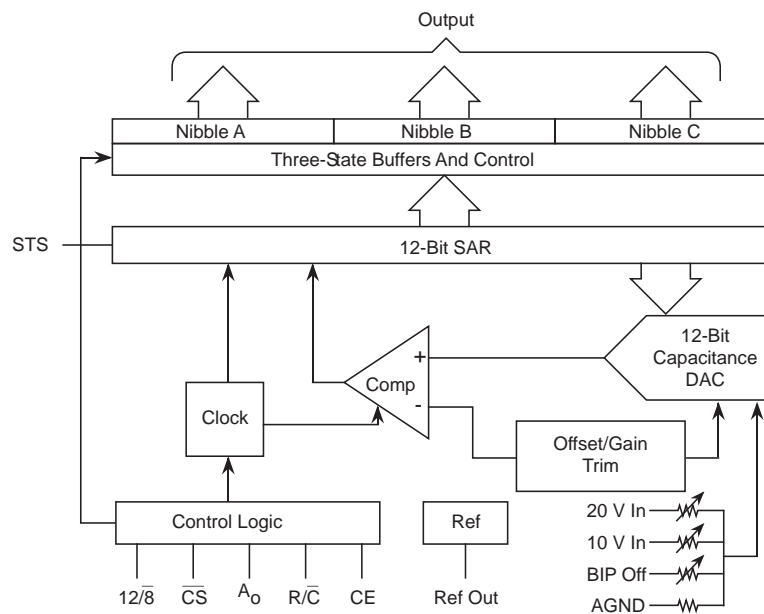

ABSOLUTE MAXIMUM RATINGS (Beyond which damage may occur) ¹ 25 °C

Supply Voltages

Mode Control Voltage (V_{EE} to DGND) 0 to +7 V
 Logic Supply Voltage (V_{DD} to DGND) 0 to +7 V
 Analog to Digital Ground (AGND to DGND) ±1 V

Input Voltages

Control Input Voltages (to DGND)
 (CE, CS, Ao, 12/8, R/C) -0.5 to V_{DD} +0.5 V
 Analog Input Voltage (to AGND)
 (REF IN, BIP OFF, 10 V_{IN}) ±16.5 V
 20 V V_{IN} Input Voltage (to AGND) ±24 V

Output

Reference Output Voltage Indefinite Short to GND
 Momentary Short to V_{DD}

Temperature

Operating Temperature, Ambient 0 to +70 °C
 Junction +165 °C
 Lead Temperature, (Soldering 10 Seconds) +300 °C
 Storage Temperature -65 to +150 °C

Note: Operation at any Absolute Maximum Rating is not implied. See Operating Conditions for proper nominal applied conditions in typical applications.

ELECTRICAL SPECIFICATIONS

T_A = T_{MIN} to T_{MAX}, V_{EE} = 0 to +5 V, V_{DD} = +5 V, f_S = 117 kHz, f_{IN} = 10 kHz, unless otherwise specified..

PARAMETER	TEST CONDITIONS	TEST LEVEL	SPT674C			SPT674B			UNITS
			MIN	TYP	MAX	MIN	TYP	MAX	
DC ELECTRICAL CHARACTERISTICS									
Resolution		VI			12			12	Bits
Linearity Error	T _A = 0 to +70 °C	VI			±1			±0.5	LSB
Differential Linearity	No Missing Codes	VI	12			12			Bits
Unipolar Offset; 10 V, 20 V	+25 °C Adjustable to Zero	VI			±4			±4	LSB
Bipolar Offset; ±5 V, ±10 V	+25 °C Adjustable to Zero	VI			±10			±6	LSB
Full Scale Calibration Error ¹	+25 °C Adjustable to Zero	VI			0.30			0.30	% of FS
Full Scale Calibration Error ¹	No Adjustment to Zero T _A = 0 to +70 °C	V			0.47			0.37	% of FS
Temperature Coefficients	Using Internal Reference								
Unipolar Offset		V			±1.0			±1.0	ppm/°C
Bipolar Offset		V			±2.0			±2.0	ppm/°C
Full Scale Calibration		V			±12			±12	ppm/°C
Power Supply Rejection +4.75 V < V _{DD} < +5.25 V	Max change in full scale calibration	VI			±0.5			±0.5	LSB
Analog Input Ranges									
Bipolar		VI	-5		+5	-5		+5	Volts
		VI	-10		+10	-10		+10	Volts
Unipolar		VI	0		+10	0		+10	Volts
		VI	0		+20	0		+20	Volts
Input Impedance									
10 Volt Span		VI	8.5		12	8.5		12	kΩ
20 Volt Span		VI	35		50	35		50	kΩ

ELECTRICAL SPECIFICATIONS

T_A = T_{MIN} to T_{MAX}, V_{EE} = 0 to +5 V, V_{DD} = +5 V, f_S = 117 kHz, f_{IN} = 10 kHz, unless otherwise specified.

PARAMETER	TEST CONDITIONS	TEST LEVEL	SPT674C			SPT674B			UNITS
			MIN	TYP	MAX	MIN	TYP	MAX	
DC ELECTRICAL CHARACTERISTICS									
Power Supplies Operating Voltage Range									
V _{DD}		IV	+4.5		+5.5	+4.5		+5.5	Volts
V _{EE2}		IV			V _{DD}			V _{DD}	Volts
Operating Current									
I _{DD}		IV		15	24		15	24	mA
I _{EE2}	V _{EE} = +5 V	IV		167			167		μA
Power Dissipation		VI		75	120		75	120	mW
Internal Reference Voltage		VI	2.4	2.5	2.6	2.4	2.5	2.6	Volts
Output Current ³		VI	0.5			0.5			mA
DIGITAL CHARACTERISTICS									
Logic Inputs (CE, \overline{CS} , R/ \overline{C} , Ao, 12/8)									
Logic 0		VI	-0.5		+0.8	-0.5		+0.8	Volts
Logic1		VI	2.0		5.5	2.0		5.5	Volts
Current		VI	-5.0	0.1	5.0	-5.0	0.1	5.0	μA
Capacitance		V		5			5		pF
Logic Outputs (DB11-DB0, STS)									
Logic 0	(I _{SINK} = 1.6 mA)	VI			+0.4			+0.4	Volts
Logic 1	(I _{SOURCE} = 500 μA)	VI	+2.4			+2.4			Volts
Leakage	(High Z State, DB11-DB0 Only)	VI	-5	0.1	+5	-5	0.1	+5	μA
Capacitance		V		5			5		pF
AC Accuracy	f _S =117 kHz, f _{IN} =10 kHz								
Spurious Free Dyn. Range		V	73	78		76	78		dB
Total Harmonic Distortion		V		-77	-72		-77	-75	dB
Signal-to-Noise Ratio		V	69	72		71	72		dB
Signal-to-Noise & Distortion (SINAD)		V	68	71		70	71		dB
Intermodulation Distortion	f _{IN1} =20 kHz; f _{IN2} =23 kHz	V		-75			-75		dB

Note 1: Fixed 50 Ω resistor from REF OUT to REF IN and REF OUT to BIP OFF.

Note 2: V_{EE} is optional and is only used to set the mode for the internal sample/hold. When not using V_{EE}, the pin should be treated as a no connect. If V_{EE} is connected to 0 to -15 V, aperture delay (t_{AP}) will increase from 20 ns (typ) to 4000 ns (typ).

Note 3: Available for external loads; external load should not change during conversion.

ELECTRICAL SPECIFICATIONS

T_A = T_{MIN} to T_{MAX}, V_{EE} = 0 to +5 V, V_{DD} = +5 V, f_S = 117 kHz, f_{IN} = 10 kHz, unless otherwise specified.

PARAMETER	TEST CONDITIONS	TEST LEVEL	SPT674C			SPT674B			UNITS
			MIN	TYP	MAX	MIN	TYP	MAX	
AC ELECTRICAL CHARACTERISTICS⁴									
Convert Mode Timing									
t _{DSC} STS Delay from CE		VI		60	200		60	200	ns
t _{HEC} CE Pulse Width		VI	50	30		50	30		ns
t _{SSC} $\overline{\text{CS}}$ to CE Setup		VI	50	20		50	20		ns
t _{HSC} $\overline{\text{CS}}$ Low during CE High		VI	50	20		50	20		ns
t _{SRC} R/ $\overline{\text{C}}$ to CE Setup		VI	50	0		50	0		ns
t _{HRC} R/ $\overline{\text{C}}$ Low During CE High		VI	50	20		50	20		ns
t _{SAC} Ao to CE Setup		VI	0			0			ns
t _{HAC} Ao Valid During CE High		VI	50	20		50	20		ns
t _c Conversion Time ⁵									
12-Bit Cycle		VI	9	13	15	9	13	15	μs
8-Bit Cycle		VI	6	8	10	6	8	10	μs
Read Mode Timing									
t _{DD} Access Time from CE		VI		75	150		75	150	ns
t _{HD} Data Valid After CE Low		VI	25	35		25	35		ns
t _{HL} Output Float Delay		VI		100	150		100	150	ns
t _{SSR} $\overline{\text{CS}}$ to CE Setup		VI	50	0		50	0		ns
t _{SRR} R/ $\overline{\text{C}}$ to CE Setup		VI	0			0			ns
t _{SAR} Ao to CE Setup		VI	50	25		50	25		ns
t _{HSR} $\overline{\text{CS}}$ Valid After CE Low		VI	0			0			ns
t _{HRR} R/ $\overline{\text{C}}$ High After CE Low		VI	0			0			ns
t _{HS} STS Delay After Data Valid		VI	100	300	600	100	300	600	ns
t _{HAR} Ao Valid after CE Low		VI	50			50			ns

Note 4: Time is measured from 50% level of digital transitions.

Note 5: Includes acquisition time.

Figure 1 - Convert Mode Timing Diagram

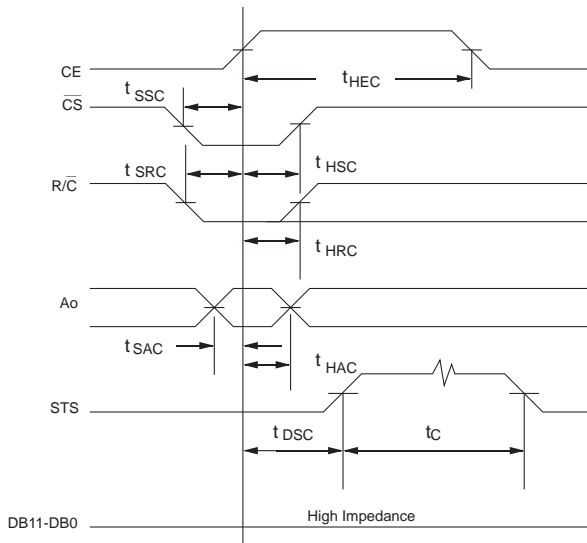
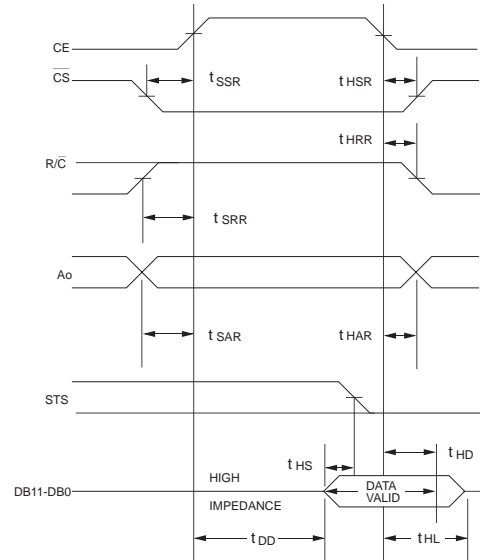

Figure 2 - Read Mode Timing Diagram



ELECTRICAL SPECIFICATIONS

T_A = T_{MIN} to T_{MAX}, V_{EE} = 0 to +5 V, V_{DD} = +5 V, f_S = 117 kHz, f_{IN} = 10 kHz, unless otherwise specified.

PARAMETER	TEST CONDITIONS	TEST LEVEL	SPT674C			SPT674B			UNITS
			MIN	TYP	MAX	MIN	TYP	MAX	
AC ELECTRICAL CHARACTERISTICS⁴									
Stand-Alone Mode Timing									
t _{HRL} Low R/ \bar{C} Pulse Width		VI	25			25			ns
t _{DS} STS Delay from R/ \bar{C}		VI			200			200	ns
t _{HDR} Data Valid After R/ \bar{C} Low		VI	25			25			ns
t _{HS} STS Delay After Data Valid		VI	100	300	600	100	300	600	ns
t _{HRH} High R/ \bar{C} Pulse Width		VI	100			100			ns
t _{DDR} Data Access Time Sample-and-Hold		VI			150			150	ns
Aperture Delay	V _{EE} = +5 V	IV		20			20		ns
Aperture Uncertainty Time	V _{EE} = +5 V	V		300			300		ps, RMS

TEST LEVEL CODES

All electrical characteristics are subject to the following conditions:

All parameters having min/max specifications are guaranteed. The Test Level column indicates the specific device testing actually performed during production and Quality Assurance inspection. Any blank section in the data column indicates that the specification is not tested at the specified condition.

TEST LEVEL

TEST PROCEDURE

- I 100% production tested at the specified temperature.
- II 100% production tested at T_A=25 °C, and sample tested at the specified temperatures.
- III QA sample tested only at the specified temperatures.
- IV Parameter is guaranteed (but not tested) by design and characterization data.
- V Parameter is a typical value for information purposes only.
- VI 100% production tested at T_A = 25 °C. Parameter is guaranteed over specified temperature range.

Figure 3 - Low Pulse for R/ \bar{C} - Outputs Enabled After Conversion

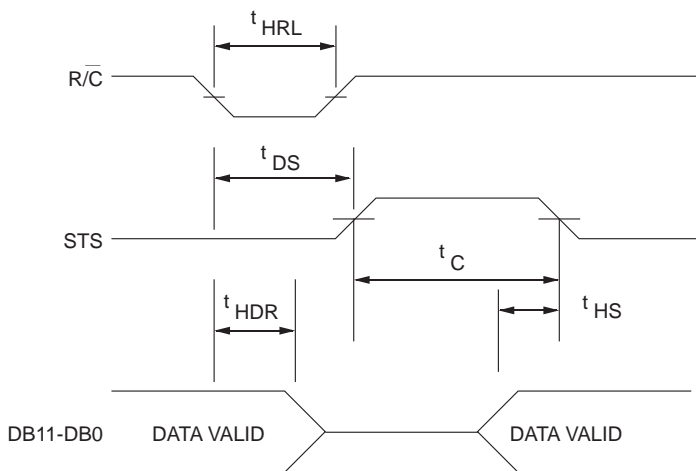
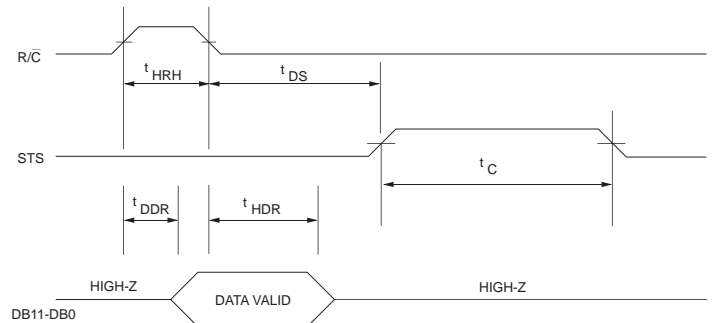

Figure 4 - High Pulse for R/ \bar{C} - Outputs Enabled While R/ \bar{C} is High, Otherwise High Impedance



CIRCUIT OPERATION

The SPT674 is a complete 12-bit analog-to-digital converter that consists of a single chip version of the industry standard 674. This single chip contains a precision 12-bit capacitor digital-to-analog converter (CDAC) with voltage reference, comparator, successive approximation register (SAR), sample-and-hold, clock, output buffers and control circuitry to make it possible to use the SPT674 with few external components.

When the control section of the SPT674 initiates a conversion command, the clock is enabled and the successive-approximation register is reset to all zeros. Once the conversion cycle begins, it cannot be stopped or restarted and data is not available from the output buffers.

The SAR, timed by the clock, sequences through the conversion cycle and returns an end-of-convert flag to the control section of the ADC. The clock is then disabled by the control section, the output status goes low, and the control section is enabled to allow the data to be read by external command.

The internal SPT674 12-bit CDAC is sequenced by the SAR starting from the MSB to the LSB at the beginning of the conversion cycle to provide an output voltage from the CDAC that is equal to the input signal voltage (which is divided by the input voltage divider network). The comparator determines whether the addition of each successively-weighted bit voltage causes the CDAC output voltage summation to be greater or less than the input voltage; if the sum is less, the bit is left on; if more, the bit is turned off. After testing all the bits, the SAR contains a 12-bit binary code which accurately represents the input signal to within $\pm 1/2$ LSB.

The internal reference provides the voltage reference to the CDAC with excellent stability over temperature and time. The reference is trimmed to 2.5 volts and can supply at least 0.5 mA to an external load. Any external load on the SPT674 reference must remain constant during conversion.

The sample-and-hold feature is a bonus of the CDAC architecture. Therefore the majority of the S/H specifications are included within the A/D specifications.

Although the sample-and-hold circuit is not implemented in the classical sense, the sampling nature of the capacitive DAC makes the SPT674 appear to have a built-in sample-and-hold. This sample-and-hold action substantially increases the signal bandwidth of the SPT674 over that of similar competing devices.

Note that even though the user may use an external sample-and-hold for very high frequency inputs, the internal sample-and-hold still provides a very useful isolation function. Once the internal sample is taken by the CDAC capacitance, the input of the SPT674 is disconnected from the user's sample-and-hold. This prevents transients occurring during conversion from affecting the attached sample-and-hold buffer. All

other 674 circuits will cause a transient load current on the sample-and-hold which will upset the buffer output and may add error to the conversion itself.

Furthermore, the isolation of the input after the acquisition time in the SPT674 allows the user an opportunity to release the hold on an external sample-and-hold and start it tracking the next sample. This increases system throughput with the user's existing components.

TYPICAL INTERFACE CIRCUIT

The SPT674 is a complete A/D converter that is fully operational when powered up and issued a Start Convert Signal. Only a few external components are necessary as shown in figures 5 and 6. The two typical interface circuits are for operating the SPT674 in either an unipolar or bipolar input mode. Information on these connections and on conditions concerning board layout to achieve the best operation are discussed below.

For each application of this device, strict attention must be given to power supply decoupling, board layout (to reduce pickup between analog and digital sections), and grounding. Digital timing, calibration and the analog signal source must be considered for correct operation.

POWER SUPPLIES

The supply voltage for the SPT674 must be kept as quiet as possible from noise pickup and also regulated from transients or drops. Because the part has 12-bit accuracy, voltage spikes on the supply lines can cause several LSB deviations on the output. Switching power supply noise can be a problem. Careful filtering and shielding should be employed to prevent the noise from being picked up by the converter.

V_{DD} should be bypassed with a 10 μ F tantalum capacitor located close to the converter to filter noise and counter the problems caused by the variations in supply current. V_{EE} is only used as a logic input and is immune to typical supply variation.

GROUNDING CONSIDERATIONS

Resistance of any path between the analog and digital grounds should be as low as possible to accommodate the ground currents present with this device.

To achieve specified accuracy, a double-sided printed circuit board with a copper ground plane on the component side is recommended. Keep analog signal traces away from digital lines. It is best to lay the PC board out such that there is an analog section and a digital section with a single point ground connection between the two through an RF bead located as close to the device as possible. If possible, run analog signals between ground traces and cross digital lines at right angles only.

The analog and digital common pins should be tied together as close to the package as possible to guarantee best performance. The code dependent currents flow through the V_{DD} terminal and not through the analog and digital common pins.

RANGE CONSIDERATIONS

The SPT674 may be operated by a microprocessor or in the stand-alone mode. The part has four standard input ranges: 0 V to +10 V, 0 V to +20 V, ± 5 V and ± 10 V. The maximum errors that are listed in the specifications for gain and offset may be adjusted externally to zero as explained in the next two sections.

CALIBRATION & CONNECTION PROCEDURES

UNIPOLAR

The calibration procedure consists of adjusting the converter's most negative output to its ideal value for offset adjustment and then adjusting the most positive output to its ideal value for gain adjustment.

Starting with offset adjustment and referring to figure 5, the midpoint of the first LSB increment should be positioned at the origin to get an output code of all 0s. To do this, an input of +1/2 LSB or +1.22 mV for the 10 V range and +2.44 mV for the 20 V range should be applied to the SPT674. Adjust the offset potentiometer R1 for code transition flickers between 0000 0000 0000 and 0000 0000 0001.

Figure 5 - Unipolar Input Connections

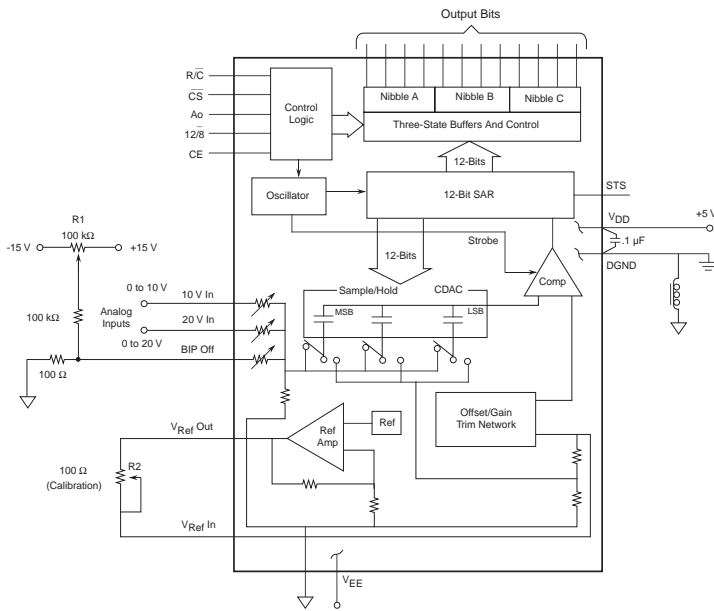

The gain adjustment should be done at positive full scale. The ideal input corresponding to the last code change is applied. This is 1 and 1/2 LSB below the nominal full scale which is +9.9963 V for the 10 V range and +19.9927 V for the 20 V range. Adjust the gain potentiometer R2 for flicker between codes 1111 1111 1110 and 1111 1111 1111. If calibration is not necessary for the intended application, replace R2 with a 50 Ω , 1% metal film resistor and remove the network from the BIP OFF pin. Connect the BIP OFF pin to AGND. Connect the analog input to the 10 V IN pin for the 0 to 10 V range or to the 20 V IN pin for the 0 to 20 V range.

BIPOLAR

The gain and offset errors listed in the specification may be adjusted to zero using the potentiometers R1 and R2. (See figure 6.) If adjustment is not needed, either or both pots may be replaced by a 50 Ω , 1% metal film resistor.

To calibrate, connect the analog input signal to the 10 V IN pin for a ± 5 V range or to the 20 V IN pin for a ± 10 V range. First apply a DC input voltage 1/2 LSB above negative full scale which is -4.9988 V for the ± 5 V range or -9.9976 V for the ± 10 V range. Adjust the offset potentiometer R1 for flicker between output codes 0000 0000 0000 and 0000 0000 0001. Next, apply a DC input voltage 1 and 1/2 LSB below positive full scale which is +4.9963 V for the ± 5 V range or +9.9927 V for the ± 10 V range. Adjust the gain potentiometer R2 for flicker between codes 1111 1111 1110 and 1111 1111 1111.

Figure 6 - Bipolar Input Connections

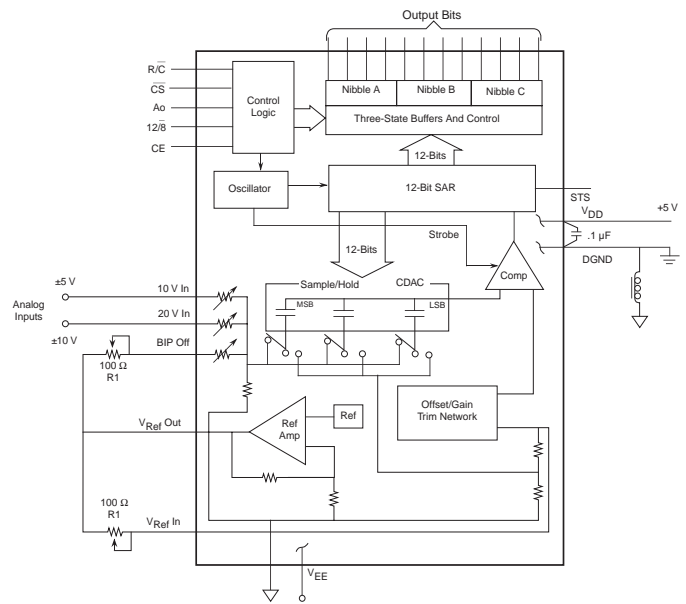

ALTERNATIVE

In some applications, a full scale of 10.24 V (for an LSB of 2.5 mV) or 20.48 V (for an LSB of 5.0 mV) is more convenient. In the unipolar mode of operation, replace R2 with a 200 Ω potentiometer and add 150 Ω in series with the 10 V IN pin for 10.24 V input range or 500 Ω in series with the 20 V IN pin for 20.48 V input range. In bipolar mode of operation, replace R1 with a 500 Ω potentiometer (in addition to the previous changes). The calibration will remain similar to the standard calibration procedure.

CONTROLLING THE SPT674

The SPT674 can be operated by most microprocessor systems due to the control input pins and on-chip logic. It may also be operated in the stand-alone mode and enabled by the R/\overline{C} input pin. Full μP control consists of selecting an 8 or 12-bit conversion cycle, initiating the conversion, and reading the output data when ready. The output read has the options of choosing either 12-bits at once or 8 bits followed by 4-bits in a left-justified format. All five control inputs are TTL/CMOS compatible and include $12/\overline{8}$, \overline{CS} , A_o , R/\overline{C} and CE. The use of these inputs in controlling the converter's operations is shown in table I, and the internal control logic is shown in a simplified schematic in figure 10.

STAND-ALONE OPERATION

The simplest interface is a control line connected to R/\overline{C} . The output controls must be tied to known states as follows: CE and $12/\overline{8}$ are wired high, A_o and \overline{CS} are wired low. The output data arrives in words of 12-bits each. The limits on R/\overline{C} duty cycle are shown in figures 3 and 4. It may have a duty cycle within and including the extremes shown in the specifications. In general, data may be read when R/\overline{C} is high unless STS is also high, indicating a conversion is in progress.

Table I - Truth Table for the SPT674 Control Inputs

CE	\overline{CS}	R/\overline{C}	$12/\overline{8}$	A_o	Operation
0	X	X	X	X	None
X	1	X	X	X	None
↑	0	0	X	0	Initiate 12 bit conversion
↑	0	0	X	1	Initiate 8 bit conversion
1	↓	0	X	0	Initiate 12 bit conversion
1	↓	0	X	1	Initiate 8 bit conversion
1	0	↓	X	0	Initiate 12 bit conversion
1	0	↓	X	1	Initiate 8 bit conversion
1	0	1	1	X	Enable 12 bit Output
1	0	1	0	0	Enable 8 MSB's Only
1	0	1	0	1	Enable 4 LSB's Plus 4 Trailing Zeroes

Figure 7 - Interfacing the SPT674 to an 8-Bit Data Bus

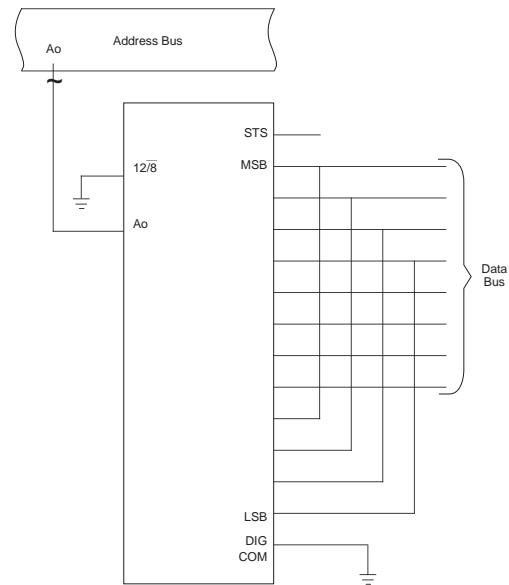

CONTROLLED OPERATION

CONVERSION LENGTH

A conversion start transition latches the state of A_o as shown in figure 7 and table I. The latched state determines if the conversion stops with 8 bits (A_o high) or continues for 12 bits (A_o low). If all 12 bits are read following an 8-bit conversion, the three LSBs will be a logic 0 and DB3 will be a logic 1. A_o is latched because it is also involved in enabling the output buffers as will be explained later. No other control inputs are latched.

CONVERSION START

A conversion may be initiated by a logic transition on any of the three inputs: CE, \overline{CS} , R/\overline{C} , as shown in table I. The last of the three to reach the correct state starts the conversions, so one, two or all three may be dynamically controlled. The nominal delay from each is the same and all three may change state simultaneously. In order to assure that a particular input controls the start of conversion, the other two should be set up at least 50 ns earlier. Refer to the convert mode timing specifications. The Convert Start timing diagram is illustrated in figure 1.

The output signal STS is the status flag and goes high only when a conversion is in progress. While STS is high, the output buffers remain in a high impedance state so that data can not be read. Also, when STS is high, an additional Start Convert will not reset the converter or reinitiate a conversion. Note, if A_o changes state after a conversion begins, an additional Start Convert command will latch the new start of A_o and possibly cause a wrong cycle length for that conversion (8 versus 12 bits).

READING THE OUTPUT DATA

The output data buffers remain in a high impedance state until the following four conditions are met: R/\overline{C} is high, STS is low, CE is high, and \overline{CS} is low. The data lines become active in response to the four conditions and output data according to the conditions of $12/\overline{8}$ and Ao. The timing diagram for this process is shown in figure 2. When $12/\overline{8}$ is high, all 12 data outputs become active simultaneously and the Ao input is ignored. This is for easy interface to a 12 or 16-bit data bus. The $12/\overline{8}$ input is usually tied high or low, although it is TTL/CMOS compatible. When $12/\overline{8}$ is low, the output is separated into two 8-bit bytes as shown below.

Figure 8 - Output When $12/\overline{8}$ Is Low

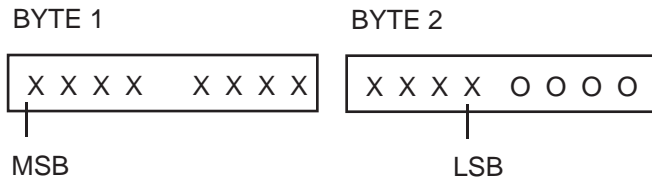

This configuration makes it easy to connect to an 8-bit data bus as shown in figure 7. The Ao control can be connected to the least significant bit of the address bus in order to store the output data into two consecutive memory locations. When Ao is pulled low, the 8 MSBs are enabled only. When Ao is high, the 4 MSBs are disabled, bits 4 through 7 are forced to a zero and the four LSBs are enabled. The two byte format is left justified data as shown above and can be considered to have a decimal point or binary to the left of byte 1.

Ao may be toggled without damage to the converter at any time. Break-before-make action is guaranteed between the two data bytes. This assures that the outputs in figure 7 will never be enabled at the same time.

In figure 2, it can be seen that a read operation usually begins after the conversion is completed and STS is low. If earlier access is needed, the read can begin no later than the addition of time t_{DD} and t_{HS} before STS goes low.

Figure 9 - S/H Control Mode Timing ($V_{EE} = +5 V$)

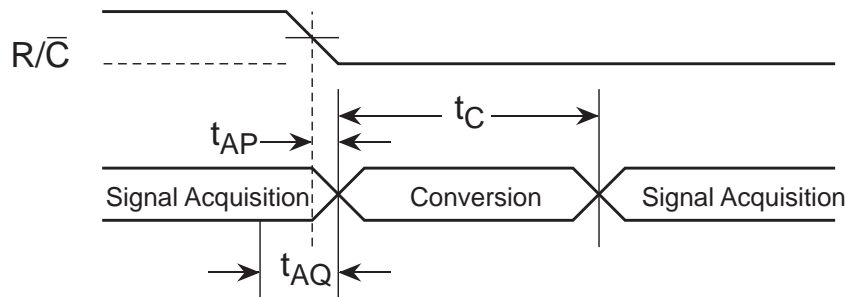

SAMPLE-AND-HOLD (S/H) CONTROL MODE

This control mode is provided to allow full use of the internal S/H, eliminating the need for an external S/H in most applications. The SPT674 in the control mode also eliminates the need for one of the control signals, usually the convert command. The command that puts the internal S/H in the hold state also initiates a conversion, reducing time constraints in many systems. As soon as the conversion is completed the internal S/H immediately begins slewing to track the input signal. See figure 9.

In the control mode it is assumed that during the required $1.4 \mu s$ acquisition time the signal is not slewing faster than the slew rate of the SPT674. No assumption is made about the input level after the convert command arrives since the input signal is sampled and conversion begins immediately after the convert command. This means that the convert command can be used to switch an input multiplexer or change gains on a programmable gain amplifier, allowing the input signal to settle before the next acquisition at the end of the conversion. Because aperture jitter is minimized by the internal S/H, a high input frequency can be converted without an external S/H. See table II.

Table II - Conversion Timing ($V_{EE} = +5 V$)

Parameter	S/H Control Mode			Units
	Min	Typ	Max	
Throughput Time ($t_{AQ}+t_C$)				
		13	15	μs
12-Bit Conversions				
8-Bit Conversions		8	10	μs
Conversion Time (t_C)				
		11.4		μs
12-Bit Conversions				
8-Bit Conversions		6.4		μs
Acquisition Time (t_{AQ})		1.4		μs
Aperture Delay (t_{AP})		20		ns
Aperture Uncertainty (t_J)		0.3		ns

Figure 10 - Control Logic

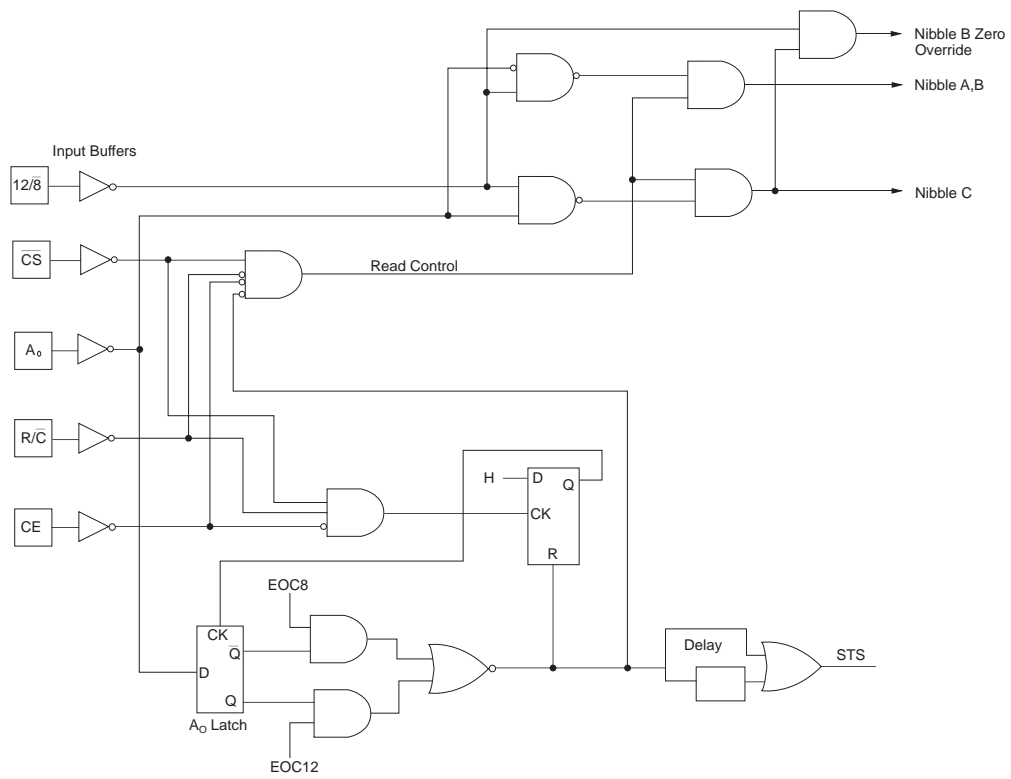

PACKAGE OUTLINE

28-Lead Sidebrazed

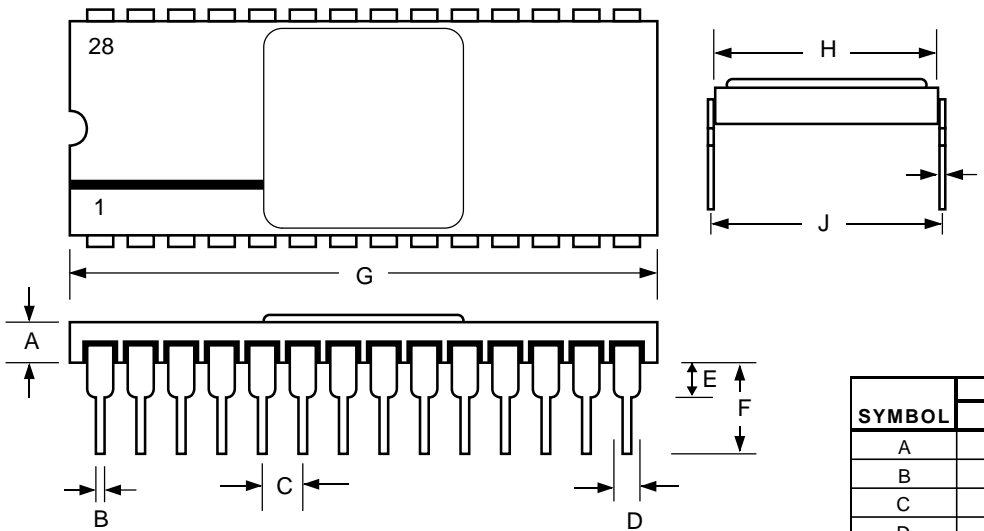

SYMBOL	INCHES		MILLIMETERS	
	MIN	MAX	MIN	MAX
A	0.077	0.093	1.96	2.36
B	0.016	0.020	0.41	0.51
C	0.095	0.105	2.41	2.67
D		.050 typ		1.27 typ
E	0.040	0.060	1.02	1.52
F	0.215	0.235	5.46	5.97
G	1.388	1.412	35.26	35.86
H	0.585	0.605	14.86	15.37
I	0.009	0.012	0.23	0.30
J	0.600	0.620	15.24	15.75

For additional information regarding our products, please visit CADEKA at: cadeka.com

CADEKA Headquarters Loveland, Colorado

T: 970.663.5452

T: 877.663.5452 (toll free)

CADEKA, the CADEKA logo design, COMLINEAR and the COMLINEAR logo design are trademarks or registered trademarks of CADEKA Microcircuits LLC. All other brand and product names may be trademarks of their respective companies.

CADEKA reserves the right to make changes to any products and services herein at any time without notice. CADEKA does not assume any responsibility or liability arising out of the application or use of any product or service described herein, except as expressly agreed to in writing by CADEKA; nor does the purchase, lease, or use of a product or service from CADEKA convey a license under any patent rights, copyrights, trademark rights, or any other of the intellectual property rights of CADEKA or of third parties.

Copyright ©2007-2008 by CADEKA Microcircuits LLC. All rights reserved.

