

KH300

Wideband, High-Speed Operational Amplifier

Features

- -3dB bandwidth of 85MHz
- 3000V/ μ sec slew rate
- 4ns rise and fall time
- 100mA output current
- Low distortion, linear phase

Applications

- Digital communications
- Baseband and video communications
- Instrument input/output amplifiers
- Fast A to D, D to A conversion
- Graphic CRT video drive amp
- Coaxial cable line driver

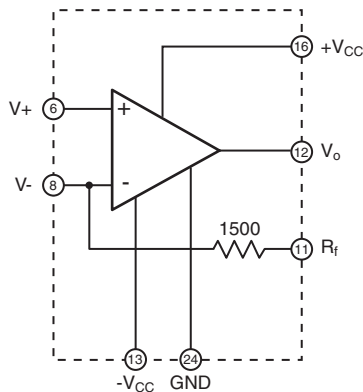

KH300 Equivalent Circuit Diagram

Pin 11 provides access to a 1500 Ω feedback resistor which can be connected to the output or left open if an external feedback resistor is desired. All undesignated pins are internally unconnected.

General Description

The KH300 operational amplifier is a current feedback amplifier that provides a DC-85MHz -3dB bandwidth that is virtually independent of gain setting. Rise and fall times of 4ns and drive capability of 22V_{pp} and 100mA add to the KH300's impressive specifications.

Using the KH300 is as easy as adding power supplies and a gain-setting resistor. Unlike conventional op amp designs in which optimum gain-bandwidth product occurs at a high gain, minimum settling time at a gain of -1, maximum slew rate at a gain of +1, et cetera, the KH300 offers consistent performance at gain settings from 1 to 40 inverting or non-inverting. As a result, designing with the KH300 is greatly simplified. And since no external compensation is necessary, "tweaks" on the production line have been eliminated, making the KH300 an efficient component for use in production situations.

Flat gain and phase response from DC to 45MHz and superior rise and fall times make the KH300 an ideal amplifier for a broad range of pulse, analog, and digital applications. A 45MHz full power bandwidth (20V_{pp} into 100 Ω) and 3000V/ μ sec slew rate eliminate the need for power buffers in many applications such as driving "flash" A to D converters or line-driving. For applications requiring lower power consumption, the KH300 can operate on supplies as low as \pm 5V. Fast overload recovery (20ns) helps prevent loss of data in communications applications and flat phase response reduces distortion, even when data must be sent over extended lengths of line.

The KH300A is packaged in a side-brazed 24-pin ceramic DIP and is specified at 25°C.

KH300 Electrical Characteristics (25°C, $V_{CC} = \pm 15V$, $R_L = 100\Omega$; unless noted)

magnitude of gain $\{ V_{out}/V_{in} \}$		4*	20			40	
PARAMETERS	CONDITIONS	TYP	MIN ²	TYP	MAX ²	TYP	UNITS
Frequency Domain Response							
-3dB bandwidth	$V_O < 4V_{pp}$	105	75	85		70	MHz
	$V_O = 20V_{pp}$	45		45		45	MHz
gain flatness	100KHz to 20MHz	± 0.25		± 0.08	± 0.3	± 0.25	dB
	20MHz to 45MHz	± 0.5		± 0.25	± 0.6	± 1	dB
phase shift		1		1.6		2	deg/MHz
deviation from linear phase	DC to 45MHz	2		3		5	deg
reverse isolation		60		70		70	dB
distortion	refer to graphs						
Time Domain Response							
rise and fall time	5V output step	3		4		5	ns
	20V output step	7		7		7	ns
settling time to 0.8%	10V output step	20		20		25	ns
overshoot (input rise time $\leq 1ns$)	5V output step	5		5		5	%
slew rate		3		3		3	V/ μs
overload recovery (200% od)	< 50ns pulse width	20		20		20	ns
General Information			MIN²	TYP	MAX²		UNITS
input offset voltage (drift)				10(25)	32		mV($\mu V/^\circ C$)
input bias current (drift)	non-inverting			10(20)	30		$\mu V(nA/^\circ C)$
	inverting			30(50)	100		$\mu V(nA/^\circ C)$
equivalent input noise ¹	integrated 0.1 to 100MHz, ($R_s = 50\Omega$, gain = 20)				22	56	μV
second/third harmonic distortion	20MHz, +10dBm			48	38		-dBc
input impedance	non-inverting			100K/3			Ω/pF
power supply rejection ratio	input referred		45	60			dB
common mode rejection ratio	input referred			64			dB
output drive voltage,current				10, 100			V, mA
supply current				24	33		mA

Min/max ratings are based on product characterization and simulation. Individual parameters are tested as noted. Outgoing quality levels are determined from tested parameters.

NOTES:

- 1) For Noise Figure, refer to *Distortion and Noise* section in text.
- 2) 100% tested at +25°C, $A_V = +20$, $R_L = 100\Omega$, and $V_{CC} = \pm 15V$.

* Refer to *Low Gain Operation* section.

Absolute Maximum Ratings

supply voltage ($\pm V_{CC}$)	16V ($\pm 5V$ min)
output current (I_o)	100mA
input voltage (V_{imax})	$(V_{CC} - 2.5)/A_V$
common mode input voltage	$\pm 1/2 V_{CC} $
power dissipation	refer to graph
junction temperature (T_J)	150°C
storage temperature	-55°C to +150°C
still air thermal resistance (θ_{ca})	+25°C/W

KH300 Performance Characteristics (25°C, $V_{CC} = \pm 15V$, $R_L = 100\Omega$; unless noted)

Non-Inverting Gain

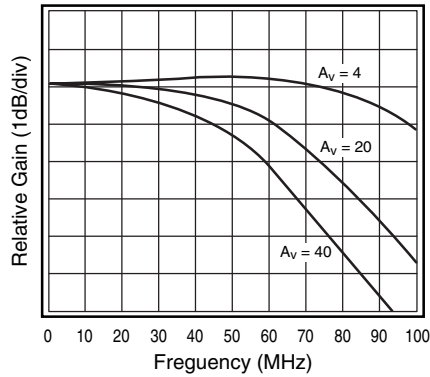

Inverting Gain

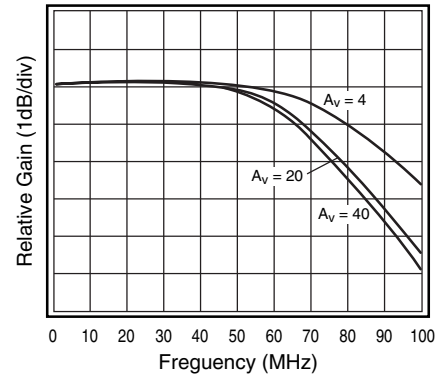

Broadband Inverting & Non-Inverting Gain

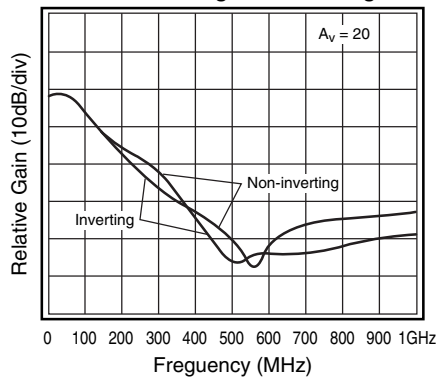

Inverting & Non-Inverting Phase

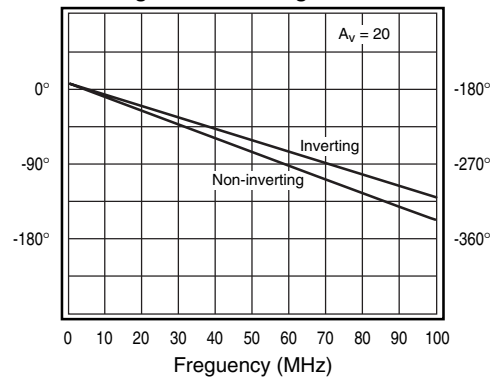

2nd & 3rd Harmonic Distortion Intercept

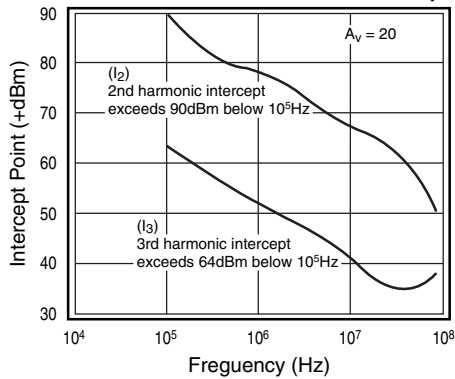

2-Tone 3rd Order Intermod. Intercept

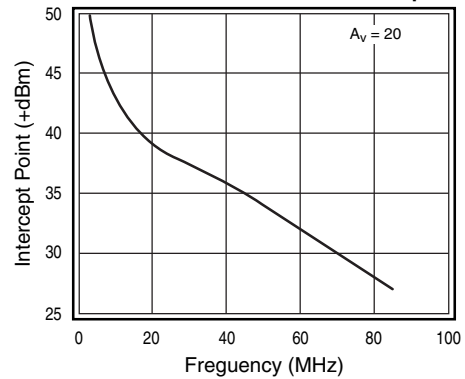

Non-Inverting Small Signal Pulse Resp.

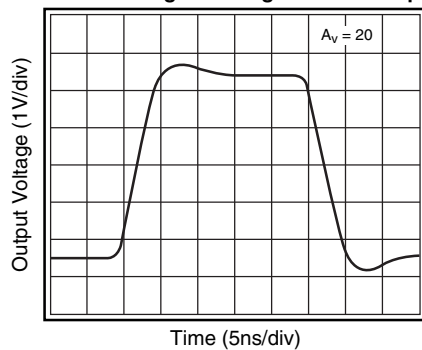

Inverting Small Signal Pulse Response

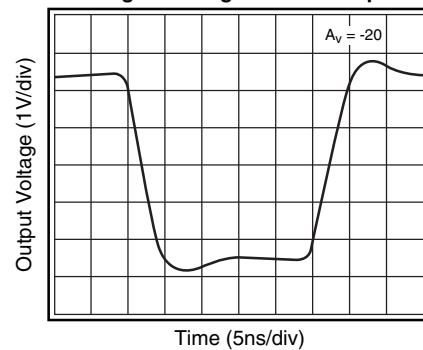

KH300 Performance Characteristics (25°C, $V_{CC} = \pm 15V$, $R_L = 100\Omega$; unless noted)

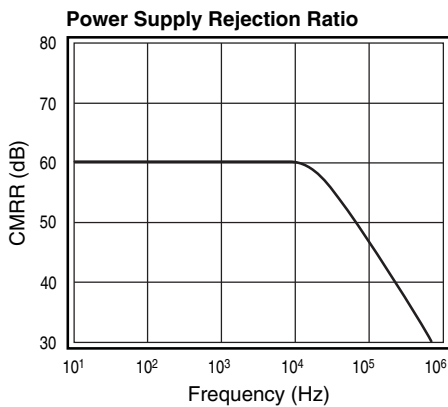
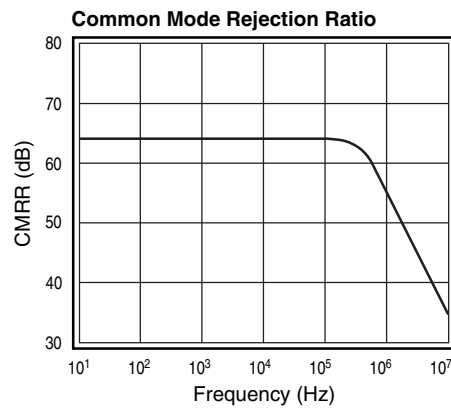
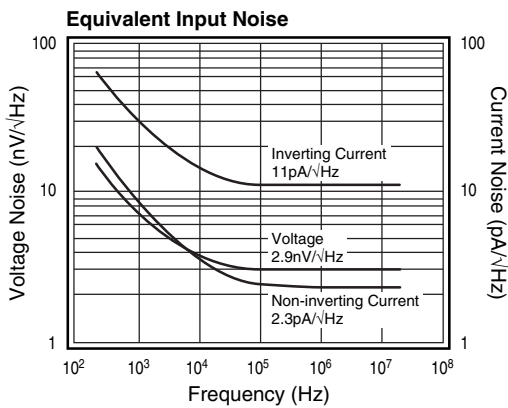
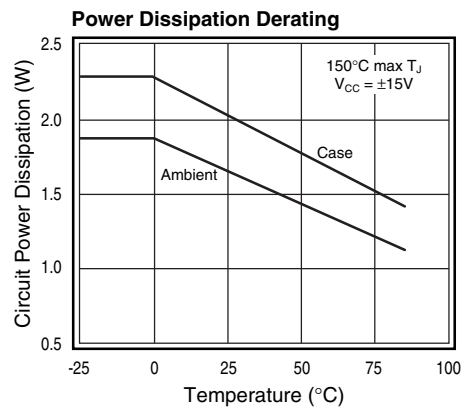
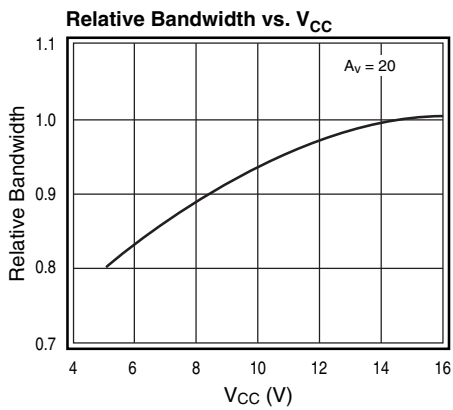
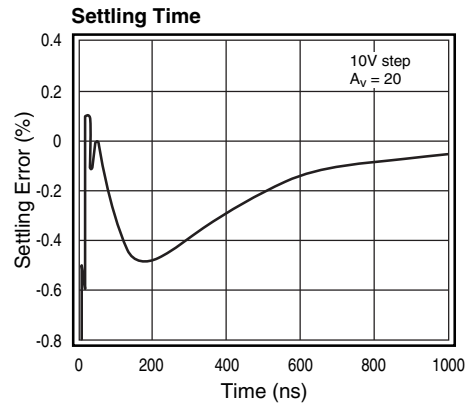
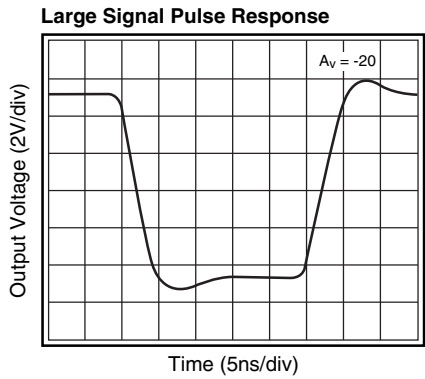

Layout Considerations

To assure optimum performance the user should follow good layout practices which minimize the unwanted coupling of signals between nodes. During initial bread-boarding of the circuit, use direct point to point wiring, keeping lead lengths to less than 0.25". The use of solid, unbroken ground plane is helpful. Avoid wire-wrap type pc boards and methods. Sockets with small, short pin receptacles may be used with minimal performance degradation although their use is not recommended.

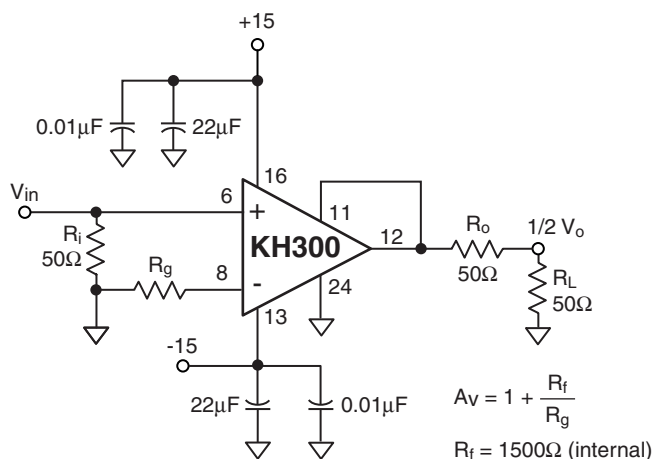

Figure 1: Recommended Non-inverting Gain Circuit

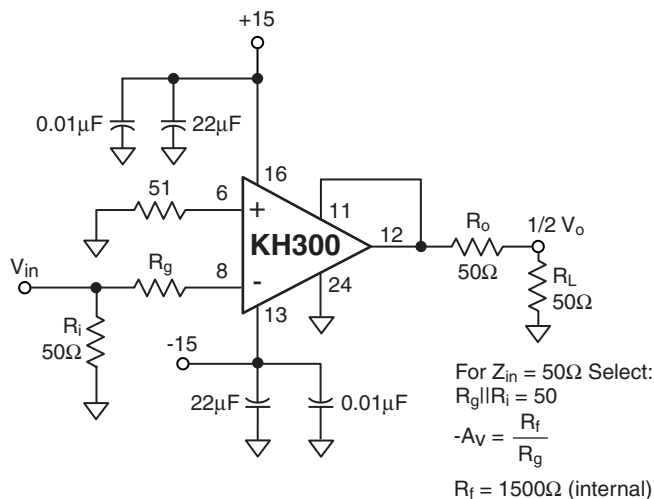

Figure 2: Recommended Inverting Gain Circuit

During pc board layout keep all traces short and direct. R_f and R_g should be as close as possible to pin 8 to minimize capacitance at that point. For the same reason, remove ground plane from the vicinity of pins 8 and 6. In other areas, use as much ground plane as possible on one side of the pc board. It is especially important to provide a ground return path for current from the load resistor to the power supply bypass capacitors. Ceramic capacitors of 0.01 to 0.1μF should be close to pins 13

and 16. Larger tantalum capacitors should also be placed within one inch of these pins. To prevent signal distortion caused by reflections from impedance mismatches, use terminated microstrip or coaxial cable when the signal must traverse more than a few inches. Since the pc board forms such an important part of the circuit, much time can be saved if prototype boards of any high frequency sections are built and tested early in the design phase.

Controlling Bandwidth and Passband Response

As with any op amp, the ratio of the two feedback resistors R_f and R_g , determines the gain of the KH300. Unlike conventional op amps, however, the closed loop pole-zero response of the KH300 is affected very little by the value of R_g . R_g scales the magnitude of the gain, but does not change the value of the feedback. R_f does influence the feedback and so the KH300 has been internally compensated for optimum performance with $R_f = 1500\Omega$, but any value of $R_f > 500\Omega$ may be used with a single capacitor placed between pins 8 and 12 for compensation. See table 1. As R_f decreases, C_c must increase to maintain flat gain. Large values of R_f and C_c can be used together or separately to reduce the bandwidth. This may be desirable for reducing the noise bandwidth in applications not requiring the full frequency response available.

Table 1: Bandwidth vs. R_f and C_c ($A_v = +20$)

R_f (KΩ)	C_c (pF)	$f_{\pm 0.3dB}$ (MHz)	$f_{-3.0dB}$ (MHz)
10.0	0	2	5
5.0	0	3	12
2.0	0	8	40
1.5	0	45	85
1.0	0.3	90	115
0.75	1.1	95	130
0.50	1.9	110	135

Low Gain Operation

The small amount of stray capacitance present at the inverting input can cause peaking which increases with decreasing gain. The gain setting resistor R_g is effectively in parallel with this capacitance and so a frequency domain pole results. With small R_g (Gain > 8), this pole is at a high frequency and it affects the closed loop gain of the KH300 only slightly. At lower values of gain, this pole becomes significant. For example, at a gain of +2, the gain may peak as much as 3dB at 75MHz, and have a bandwidth exceeding 150MHz. The same behavior does not exist for low inverting gains, however, since the inverting input is a virtual ground which maintains a constant voltage across the stray capacitance. Even at inverting gains $\ll 1$, the frequency response remains unchanged.

To avoid the peaking at low non-inverting gains, place a resistor R_p in series with the input signal path just ahead of pin 6, the non-inverting input. This forms a low pass filter with the capacitance at pin 6 which can be made to cancel the peaking due to the capacitance at pin 8, the inverting input. At a gain of +2, for example, choosing R_p such that the source impedance in parallel with R_i (see Figure 1), plus R_p equals 175Ω will flatten the frequency response. For larger gains, R_p will decrease.

Settling Time, Offset, and Drift

After an output transition has occurred, the output settles very rapidly to final value and no change occurs for several microseconds. Thereafter, thermal gradients inside the KH300 will cause the output to begin to drift. When this can not be tolerated, or when the initial offset voltage and drift is unacceptable, the use of a composite amplifier is advised. This technique reduces the offset and drift to that of a monolithic, low frequency op amp, such as an LF356A. The composite amplifier technique is fully described in the KH103 data sheet.

A simple offset adjustment can be implemented by connecting the wiper of a potentiometer, whose end terminals connect to $\pm 15V$, through a 20K resistor to pin 8 of the KH300.

Overload Protection

To avoid damage to the KH300, care must be taken to insure that the input voltage does not exceed $(|V_{CC}| - 2.5)/A_V$. High speed, low capacitance diodes should be used to limit the maximum input voltage to safe levels if a potential for overload exists.

If in the non-inverting configuration the resistor R_i , which sets the input impedance, is large, the bias current at pin 6, which is typically a few pA but which may be as large as $18\mu A$, can create a large enough input voltage to exceed the overload condition. It is therefore recommended that $R_i < [(|V_{CC}| - 2.5)/A_V]/(18\mu A)$.

Distortion and Noise

The graphs of intercept point versus frequency on the preceding page make it easy to predict the distortion at any frequency, given the output voltage of the KH300. First, convert the output voltage (V_o) to $V_{rms} = (V_{pp}/2\sqrt{2})$ and then to $P = (10\log_{10}(20V_{rms}^2))$ to get output power in dBm. At the frequency of interest, its 2nd harmonic will be $S_2 = (I_2 - P)$ dB below the level of P. Its third harmonic will be $S_3 = 2(I_3 - P)$ dB below P as will the two tone third order intermodulation products. These approximations are useful for $P < -1$ dB compression levels.

Approximate noise figure can be determined for the KH300 using the Equivalent Input Noise graph on the preceding page. The following equation can be used to determine noise figure (F) in dB:

$$F = 10 \log \left[1 + \frac{v_n^2 + \frac{i_n^2 R_f^2}{A_v^2}}{4kTR_s \Delta f} \right]$$

Where v_n is the rms noise voltage and i_n is the rms noise current. Beyond the breakpoint at the curves (i.e., where they are flat), broadband noise figure equals spot noise figure, so Δf should equal one (1) and v_n and i_n should be read directly off of the graph. Below the breakpoint, the noise must be integrated and Δf set to the appropriate bandwidth.

KH300 Package Dimensions

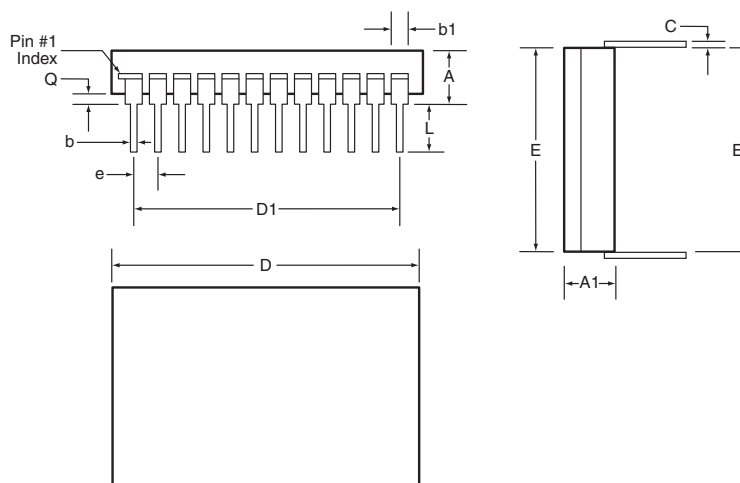

Symbol	Inches		Milimeters	
	Minimum	Maximum	Minimum	Maximum
A-Metal Lid	0.180	0.240	4.57	6.10
A-Ceramic Lid	0.195	0.255	4.95	6.48
A1-Metal Lid	0.145	0.175	3.68	4.45
A1-Ceramic Lid	0.160	0.190	4.06	4.83
b	0.014	0.026	0.36	0.66
b1	0.050 BSC		1.27 BSC	
c	0.008	0.018	0.20	0.46
D	1.275	1.310	33.39	33.27
D1	1.095	1.105	27.81	28.07
E	0.785	0.815	19.94	20.70
E1	0.790	0.810	20.07	20.57
e	0.100 BSC		2.54 BSC	
L	0.165 BSC		4.19 BSC	
Q	0.015	0.075	0.38	1.91

NOTES:

Seal: seam weld (AM, AK), epoxy (AI)
 Lead finish: gold finish

Package composition:
 Package: ceramic
 Lid: kovar/nickel (AM, AK),
 ceramic (AI)
 Leadframe: alloy 42
 Die attach: epoxy

Life Support Policy

Cadeca's products are not authorized for use as critical components in life support devices or systems without the express written approval of the president of Cadeca Microcircuits, Inc. As used herein:

1. Life support devices or systems are devices or systems which, a) are intended for surgical implant into the body, or b) support or sustain life, and whose failure to perform, when properly used in accordance with instructions for use provided in the labeling, can be reasonably expected to result in a significant injury to the user.
2. A critical component is any component of a life support device or system whose failure to perform can be reasonably expected to cause the failure of the life support device or system, or to affect its safety or effectiveness.

Cadeca does not assume any responsibility for use of any circuitry described, and Cadeca reserves the right at any time without notice to change said circuitry and specifications.