

# COMLINEAR<sup>®</sup> CLC2600, CLC3600, CLC4600

## Dual, Triple, and Quad 300MHz Amplifiers

### FEATURES

- 0.1dB gain flatness to 95MHz
- 0.03%/0.04° differential gain/phase error
- 230MHz -3dB bandwidth at  $G = 2$
- 300MHz -3dB bandwidth at  $G = 1$
- 1,300V/ $\mu$ s slew rate
- 50mA output current
- 3.3mA supply current
- Fully specified at  $\pm 5V$  supplies
- CLC2600: Pb-free SOIC-8
- CLC3600, CLC4600: Pb-free SOIC-14

### APPLICATIONS

- Video line drivers
- S-Video driver
- Video switchers and routers
- ADC buffer
- Active filters
- Cable drivers
- Twisted pair driver/receiver

### General Description

The *Comlinear* CLC2600 (dual), CLC3600 (triple), and CLC4600 (quad) are high-performance, current feedback amplifiers. These amplifiers provide 300MHz unity gain bandwidth,  $\pm 0.1$ dB gain flatness to 95MHz, and provide 1,300V/ $\mu$ s slew rate exceeding the requirements of high-definition television (HDTV) and other multimedia applications. These *Comlinear* high-performance amplifiers also provide ample output current to drive multiple video loads.

The *Comlinear* CLC2600, CLC3600, and CLC4600 are designed to operate from  $\pm 5V$  supplies. They consume only 3.3mA of supply current per channel. The combination of high-speed, low-power, and excellent video performance make these amplifiers well suited for use in many general purpose, high-speed applications including standard definition and high definition video.

### Typical Application - Driving Dual Video Loads

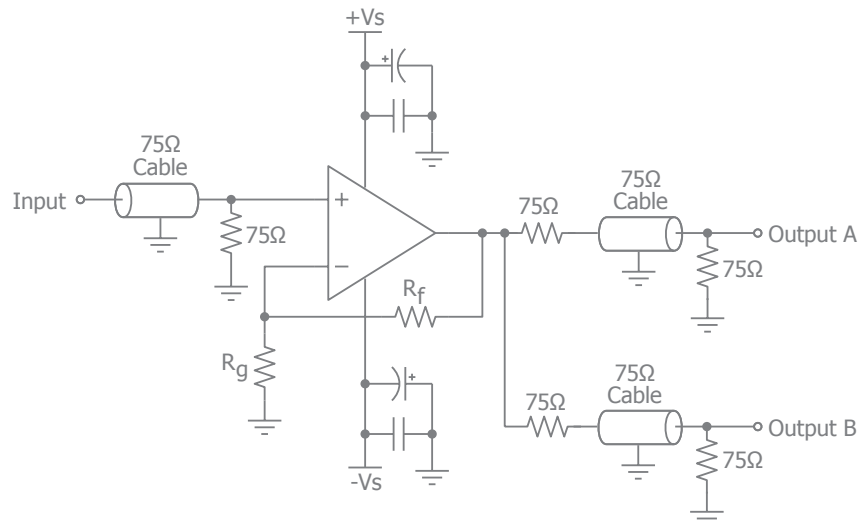

### Ordering Information

| Part Number   | Package | Pb-Free | RoHS Compliant | Operating Temperature Range | Packaging Method |
|---------------|---------|---------|----------------|-----------------------------|------------------|
| CLC2600ISO8X  | SOIC-8  | Yes     | Yes            | -40°C to +85°C              | Reel             |
| CLC2600ISO8   | SOIC-8  | Yes     | Yes            | -40°C to +85°C              | Rail             |
| CLC3600ISO14X | SOIC-14 | Yes     | Yes            | -40°C to +85°C              | Reel             |
| CLC3600ISO14  | SOIC-14 | Yes     | Yes            | -40°C to +85°C              | Rail             |
| CLC4600ISO14X | SOIC-14 | Yes     | Yes            | -40°C to +85°C              | Reel             |
| CLC4600ISO14  | SOIC-14 | Yes     | Yes            | -40°C to +85°C              | Rail             |

Moisture sensitivity level for all parts is MSL-1.



### CLC2600 Pin Configuration

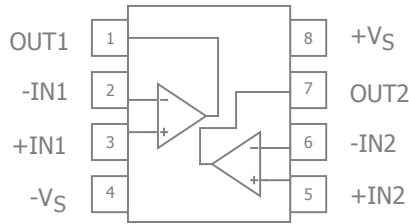

### CLC2600 Pin Assignments

| Pin No. | Pin Name | Description               |
|---------|----------|---------------------------|
| 1       | OUT1     | Output, channel 1         |
| 2       | -IN1     | Negative input, channel 1 |
| 3       | +IN1     | Positive input, channel 1 |
| 4       | -VS      | Negative supply           |
| 5       | +IN2     | Positive input, channel 2 |
| 6       | -IN2     | Negative input, channel 2 |
| 7       | OUT2     | Output, channel 2         |
| 8       | +VS      | Positive supply           |

### CLC3600 Pin Configuration

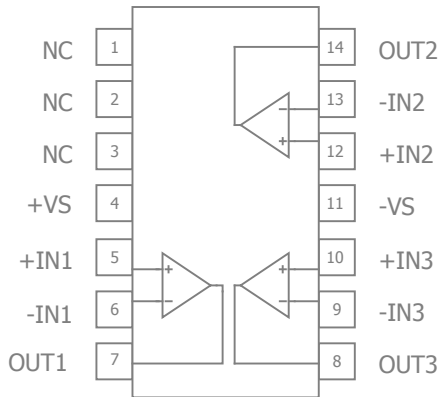

### CLC3600 Pin Configuration

| Pin No. | Pin Name | Description               |
|---------|----------|---------------------------|
| 1       | NC       | No Connect                |
| 2       | NC       | No Connect                |
| 3       | NC       | No Connect                |
| 4       | +VS      | Positive supply           |
| 5       | +IN1     | Positive input, channel 1 |
| 6       | -IN1     | Negative input, channel 1 |
| 7       | OUT1     | Output, channel 1         |
| 8       | OUT3     | Output, channel 3         |
| 9       | -IN3     | Negative input, channel 3 |
| 10      | +IN3     | Positive input, channel 3 |
| 11      | -VS      | Negative supply           |
| 12      | +IN2     | Positive input, channel 2 |
| 13      | -IN2     | Negative input, channel 2 |
| 14      | OUT2     | Output, channel 2         |

### CLC4600 Pin Configuration

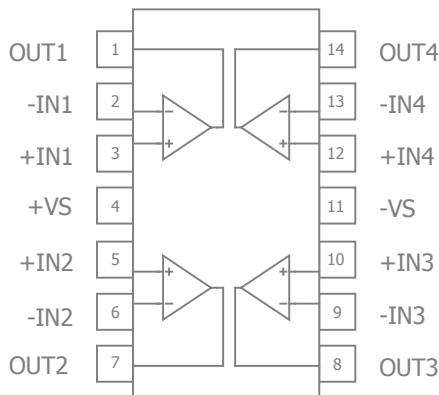

### CLC4600 Pin Configuration

| Pin No. | Pin Name | Description               |
|---------|----------|---------------------------|
| 1       | OUT1     | Output, channel 1         |
| 2       | -IN1     | Negative input, channel 1 |
| 3       | +IN1     | Positive input, channel 1 |
| 4       | +VS      | Positive supply           |
| 5       | +IN2     | Positive input, channel 2 |
| 6       | -IN2     | Negative input, channel 2 |
| 7       | OUT2     | Output, channel 2         |
| 8       | OUT3     | Output, channel 3         |
| 9       | -IN3     | Negative input, channel 3 |
| 10      | +IN3     | Positive input, channel 3 |
| 11      | -VS      | Negative supply           |
| 12      | +IN4     | Positive input, channel 4 |
| 13      | -IN4     | Negative input, channel 4 |
| 14      | OUT4     | Output, channel 4         |



## Absolute Maximum Ratings

The safety of the device is not guaranteed when it is operated above the "Absolute Maximum Ratings". The device should not be operated at these "absolute" limits. Adhere to the "Recommended Operating Conditions" for proper device function. The information contained in the Electrical Characteristics tables and Typical Performance plots reflect the operating conditions noted on the tables and plots.

| Parameter           | Min           | Max           | Unit |
|---------------------|---------------|---------------|------|
| Supply Voltage      | 0             | ±7 or 14      | V    |
| Input Voltage Range | $-V_S - 0.5V$ | $+V_S + 0.5V$ | V    |

## Reliability Information

| Parameter                         | Min | Typ | Max | Unit |
|-----------------------------------|-----|-----|-----|------|
| Junction Temperature              |     |     | 150 | °C   |
| Storage Temperature Range         | -65 |     | 150 | °C   |
| Lead Temperature (Soldering, 10s) |     |     | 260 | °C   |
| Package Thermal Resistance        |     |     |     |      |
| 8-Lead SOIC                       |     | 100 |     | °C/W |
| 14-Lead SOIC                      |     | 88  |     | °C/W |

Notes:

Package thermal resistance ( $\theta_{JA}$ ), JEDEC standard, multi-layer test boards, still air.

## ESD Protection

| Product                    | SOIC-8 | SOIC-14 |
|----------------------------|--------|---------|
| Human Body Model (HBM)     | 2.5kV  | 2.5kV   |
| Charged Device Model (CDM) | 2kV    | 2kV     |

## Recommended Operating Conditions

| Parameter                   | Min | Typ | Max | Unit |
|-----------------------------|-----|-----|-----|------|
| Operating Temperature Range | -40 |     | +85 | °C   |
| Supply Voltage Range        | ±4  |     | ±6  | V    |



## Electrical Characteristics

$T_A = 25^\circ\text{C}$ ,  $V_S = \pm 5\text{V}$ ,  $R_f = 510\Omega$ ,  $R_L = 100\Omega$ ,  $G = 2$ ; unless otherwise noted.

| Symbol                    | Parameter                                       | Conditions   | Min  | Typ       | Max | Units                        |
|---------------------------|---|--|------|-----------|-----|------------------------------|
| Frequency Domain Response |   |  |      |           |     |                              |
| UGBW                      | -3dB Bandwidth                                  | $G = +1$ , $V_{OUT} = 0.2V_{pp}$ , $R_f = 1.24k\Omega$ |      | 300       |     | MHz                          |
| BW <sub>SS</sub>          | -3dB Bandwidth                                  | $G = +2$ , $V_{OUT} = 0.2V_{pp}$                       |      | 230       |     | MHz                          |
| BW <sub>LS</sub>          | Large Signal Bandwidth                          | $G = +2$ , $V_{OUT} = 4V_{pp}$                         |      | 155       |     | MHz                          |
| BW <sub>0.1dBSS</sub>     | 0.1dB Gain Flatness                             | $G = +2$ , $V_{OUT} = 0.2V_{pp}$                       |      | 95        |     | MHz                          |
| BW <sub>0.1dBLS</sub>     | 0.1dB Gain Flatness                             | $G = +2$ , $V_{OUT} = 4V_{pp}$                         |      | 55        |     | MHz                          |
| Time Domain Response      |   |  |      |           |     |                              |
| $t_R$ , $t_F$             | Rise and Fall Time                              | $V_{OUT} = 2\text{V}$ step; (10% to 90%)               |      | 1.8       |     | ns                           |
| $t_S$                     | Settling Time to 0.1%                           | $V_{OUT} = 2\text{V}$ step                             |      | 20        |     | ns                           |
| OS                        | Overshoot                                       | $V_{OUT} = 0.2\text{V}$ step                           |      | 2.5       |     | %                            |
| SR                        | Slew Rate                                       | 4V step  |      | 1300      |     | V/ $\mu\text{s}$             |
| Distortion/Noise Response |   |  |      |           |     |                              |
| HD2                       | 2nd Harmonic Distortion                         | $2V_{pp}$ , 1MHz                                       |      | -80       |     | dBc                          |
| HD3                       | 3rd Harmonic Distortion                         | $2V_{pp}$ , 1MHz                                       |      | -86       |     | dBc                          |
| THD                       | Total Harmonic Distortion                       | $2V_{pp}$ , 1MHz                                       |      | -79.5     |     | dB                           |
| D <sub>G</sub>            | Differential Gain                               | NTSC (3.58MHz), DC-coupled, $R_L = 150\Omega$          |      | 0.03      |     | %                            |
| D <sub>P</sub>            | Differential Phase                              | NTSC (3.58MHz), DC-coupled, $R_L = 150\Omega$          |      | 0.04      |     | °                            |
| $e_n$                     | Input Voltage Noise                             | > 1MHz   |      | 6.4       |     | nV/ $\sqrt{\text{Hz}}$       |
| $i_{n+}$                  | Input Current Noise (+)                         | > 1MHz   |      | 1.0       |     | pA/ $\sqrt{\text{Hz}}$       |
| $i_{n-}$                  | Input Current Noise (-)                         | > 1MHz   |      | 9.3       |     | pA/ $\sqrt{\text{Hz}}$       |
| X <sub>TALK</sub>         | Crosstalk                                       | Channel-to-channel 5MHz                                |      | -56       |     | dB                           |
| DC Performance            |   |  |      |           |     |                              |
| V <sub>IO</sub>           | Input Offset Voltage <sup>(1)</sup>             |  | -8   | 1.4       | +8  | mV                           |
| dV <sub>IO</sub>          | Average Drift                                   |  |      | 15        |     | $\mu\text{V}/^\circ\text{C}$ |
| I <sub>bn</sub>           | Input Bias Current Non-inverting <sup>(1)</sup> |  | -3   | 1.3       | 3   | $\mu\text{A}$                |
| dI <sub>bn</sub>          | Average Drift                                   |  |      | 2.6       |     | nA/ $^\circ\text{C}$         |
| I <sub>bi</sub>           | Input Bias Current Inverting <sup>(1)</sup>     |  | -18  | 4.4       | 18  | $\mu\text{A}$                |
| dI <sub>bi</sub>          | Average Drift                                   |  |      | 16        |     | nA/ $^\circ\text{C}$         |
| PSRR                      | Power Supply Rejection Ratio <sup>(1)</sup>     | DC   | 60   | 65        |     | dB                           |
| A <sub>OL</sub>           | Open-Loop Transresistance                       | $V_{OUT} = V_S / 2$                                    |      | 580       |     | k $\Omega$                   |
| I <sub>S</sub>            | Supply Current <sup>(1)</sup>                   | CLC2600 Total  |      | 6.6       | 10  | mA                           |
|                           |   | CLC3600 Total  |      | 13.2      | 20  | mA                           |
|                           |   | CLC4600 Total  |      | 13.2      | 20  | mA                           |
| Input Characteristics     |   |  |      |           |     |                              |
| R <sub>IN</sub>           | Input Resistance                                | Non-inverting  |      | 19        |     | M $\Omega$                   |
| C <sub>IN</sub>           | Input Capacitance                               |  |      | 1         |     | pF                           |
| CMIR                      | Common Mode Input Range                         |  |      | $\pm 2.3$ |     | V                            |
| CMRR                      | Common Mode Rejection Ratio <sup>(1)</sup>      | DC   | 52   | 57        |     | dB                           |
| Output Characteristics    |   |  |      |           |     |                              |
| R <sub>O</sub>            | Output Resistance                               | Closed Loop, DC  |      | 110       |     | m $\Omega$                   |
| V <sub>OUT</sub>          | Output Voltage Swing                            | $R_L = 100\Omega$ <sup>(1)</sup>                       | -2.6 | $\pm 3$   | 2.6 | V                            |
|                           |   | $R_L = 1k\Omega$                                       |      | $\pm 3.3$ |     | V                            |
| I <sub>OUT</sub>          | Output Current                                  |  |      | 50        |     | mA                           |
| I <sub>SC</sub>           | Short-Circuit Output Current                    | $V_{OUT} = V_S / 2$                                    |      | 67        |     | mA                           |

### Notes:

1. 100% tested at 25°C

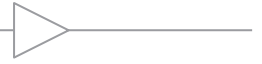

## Typical Performance Characteristics

$T_A = 25^\circ\text{C}$ ,  $V_S = \pm 5\text{V}$ ,  $R_f = 510\Omega$ ,  $R_L = 100\Omega$ ,  $G = 2$ ; unless otherwise noted.

Non-Inverting Frequency Response

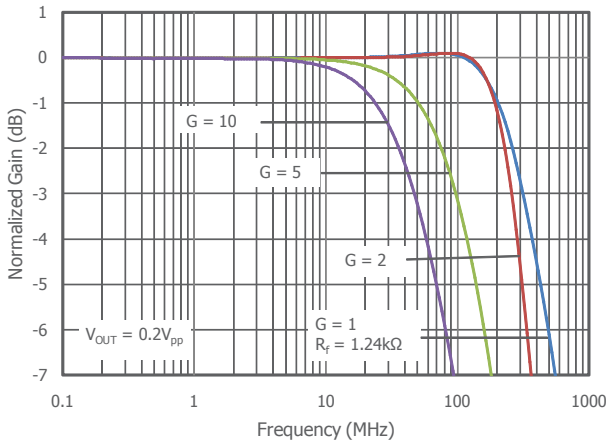

Inverting Frequency Response

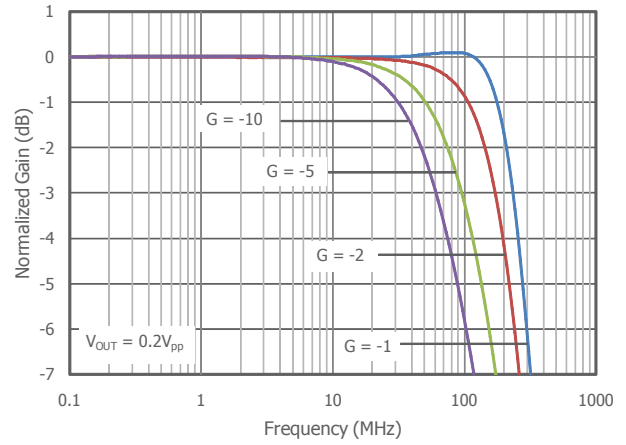

Frequency Response vs.  $C_L$

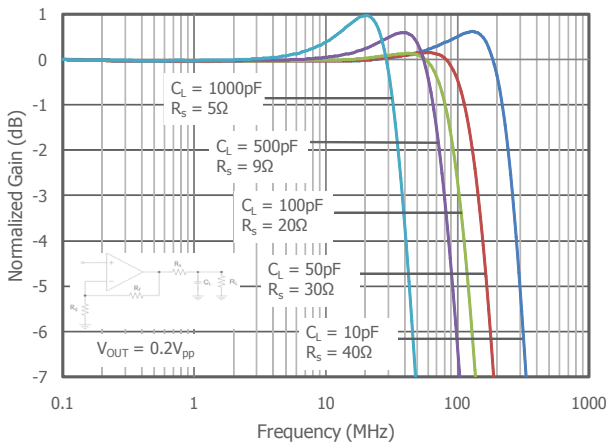

Frequency Response vs.  $R_L$

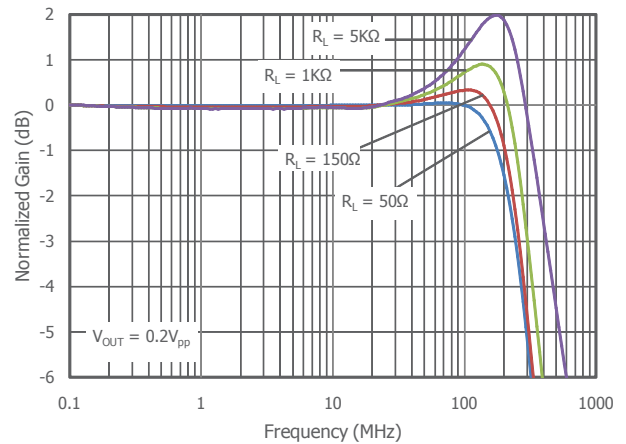

Frequency Response vs.  $V_{OUT}$

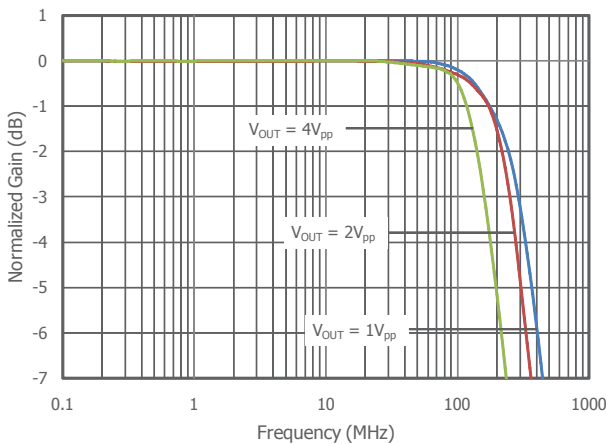

Frequency Response vs. Temperature

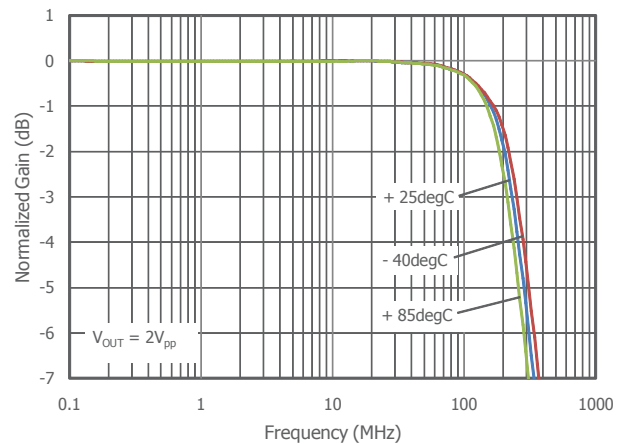

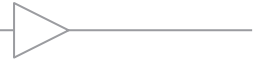

## Typical Performance Characteristics - Continued

$T_A = 25^\circ\text{C}$ ,  $V_S = \pm 5\text{V}$ ,  $R_f = 510\Omega$ ,  $R_L = 100\Omega$ ,  $G = 2$ ; unless otherwise noted.

Frequency Response vs.  $R_f$  at  $G=1$

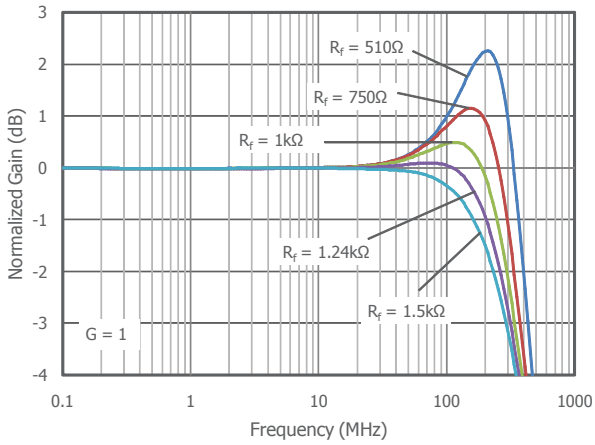

Frequency Response vs.  $R_f$  at  $G=2$

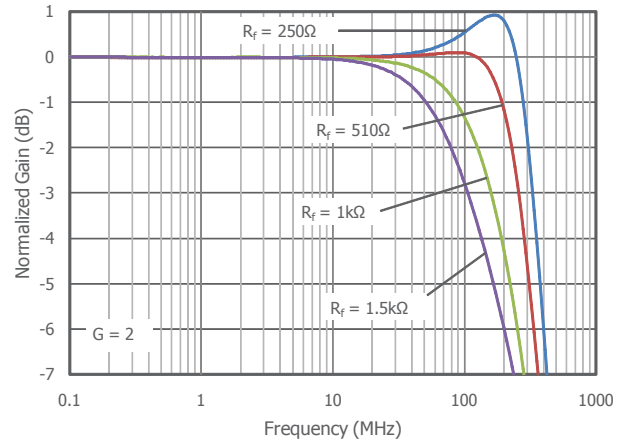

Frequency Response vs.  $R_f$  at  $G=5$

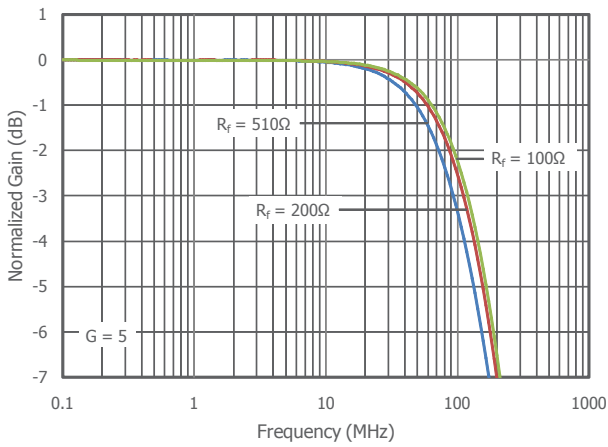

Gain Flatness

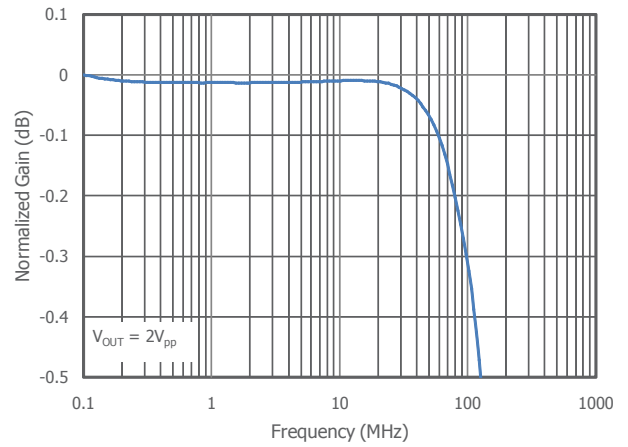

Open Loop Transimpedance Gain/Phase vs. Frequency

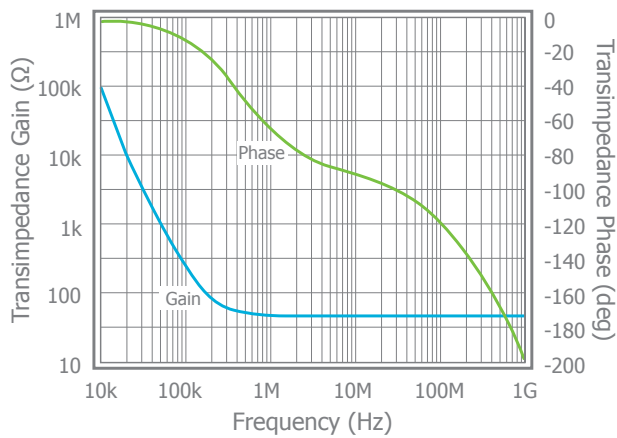

Input Voltage Noise

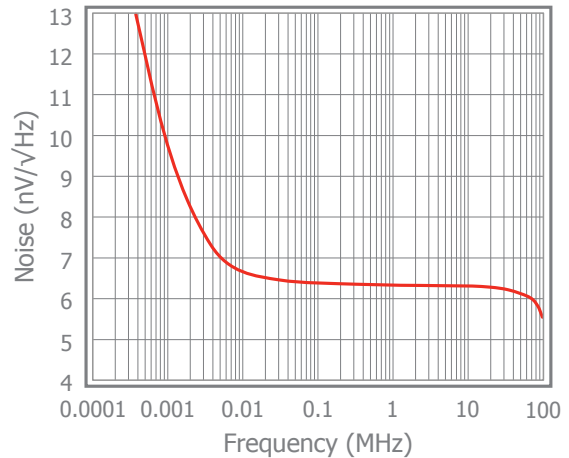

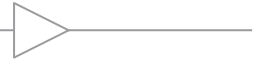

## Typical Performance Characteristics - Continued

$T_A = 25^\circ\text{C}$ ,  $V_S = \pm 5\text{V}$ ,  $R_f = 510\Omega$ ,  $R_L = 100\Omega$ ,  $G = 2$ ; unless otherwise noted.

2nd Harmonic Distortion vs.  $R_L$

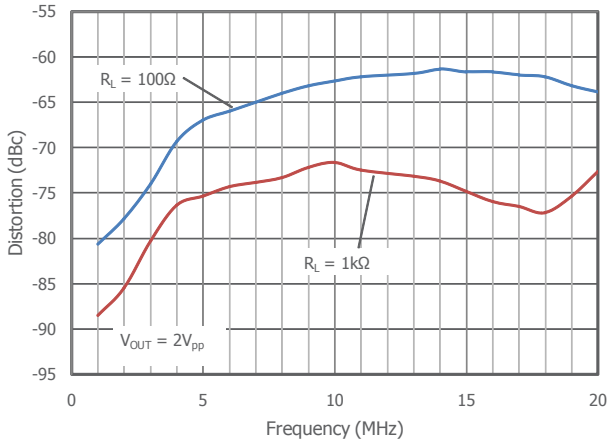

3rd Harmonic Distortion vs.  $R_L$

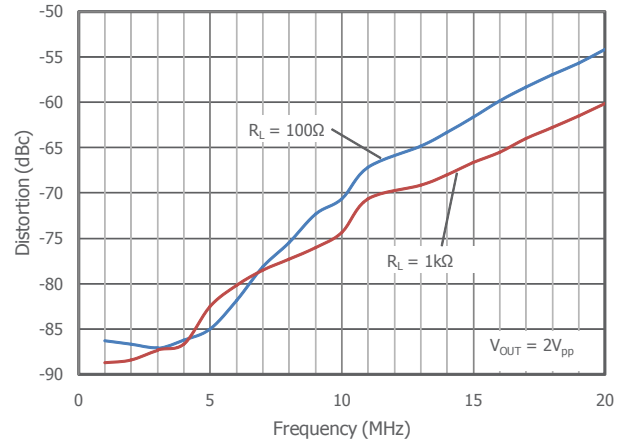

2nd Harmonic Distortion vs.  $V_{OUT}$

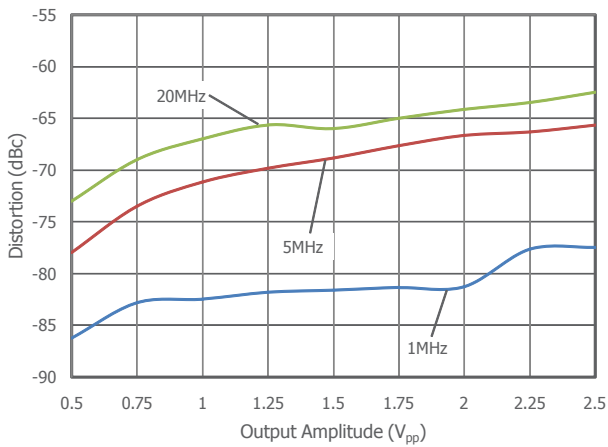

3rd Harmonic Distortion vs.  $V_{OUT}$

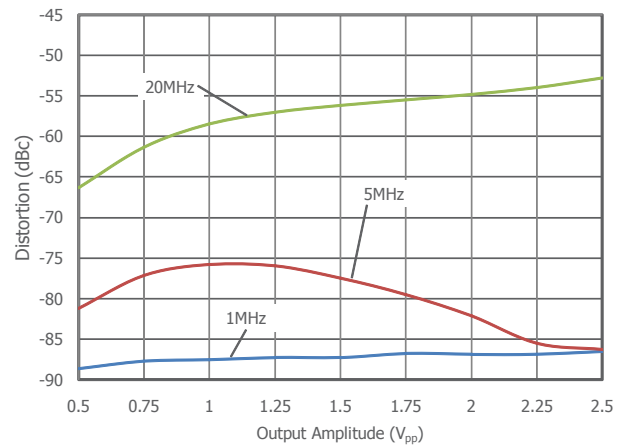

CMRR vs. Frequency

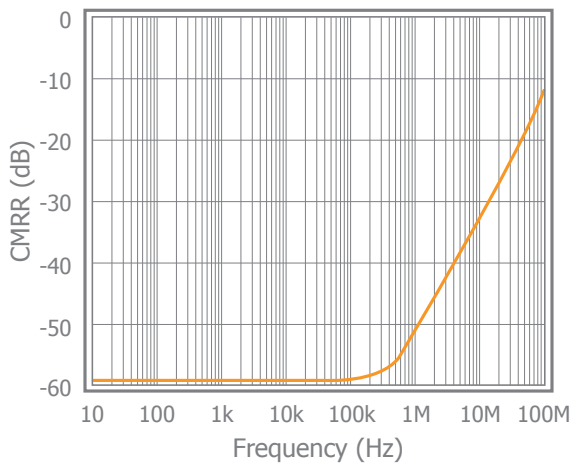

PSRR vs. Frequency

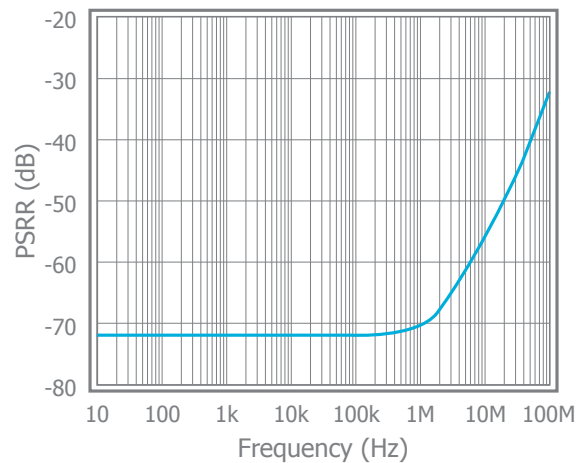

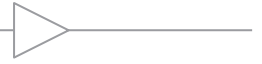

### Typical Performance Characteristics - Continued

$T_A = 25^\circ\text{C}$ ,  $V_S = \pm 5\text{V}$ ,  $R_f = 510\Omega$ ,  $R_L = 100\Omega$ ,  $G = 2$ ; unless otherwise noted.

#### Small Signal Pulse Response

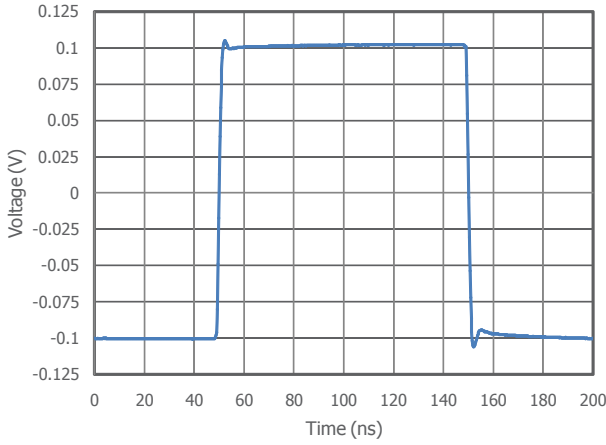

#### Large Signal Pulse Response

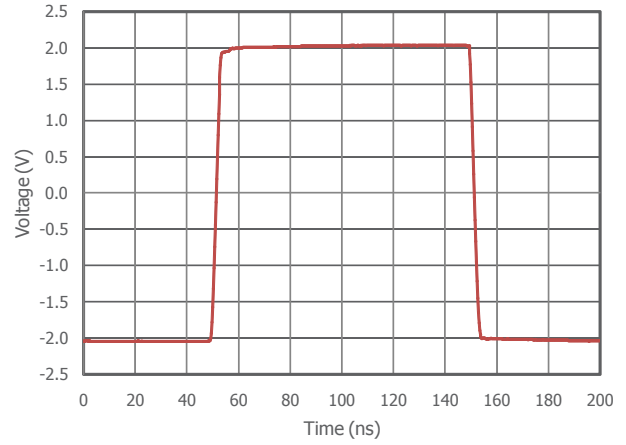

#### Crosstalk vs. Frequency

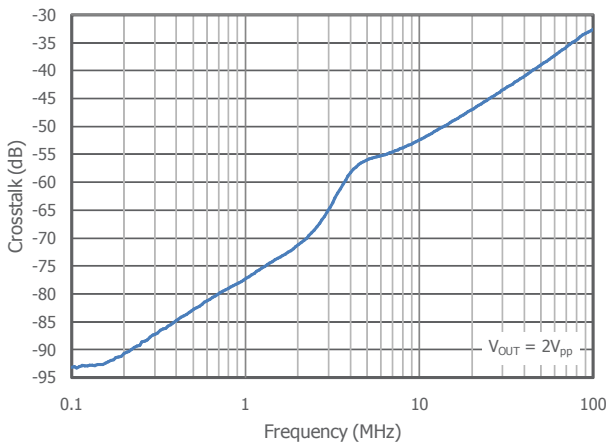

#### Closed Loop Output Impedance vs. Frequency

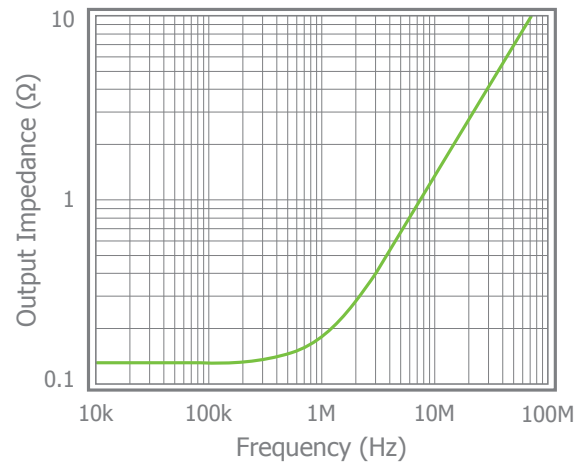

#### Differential Gain & Phase AC Coupled

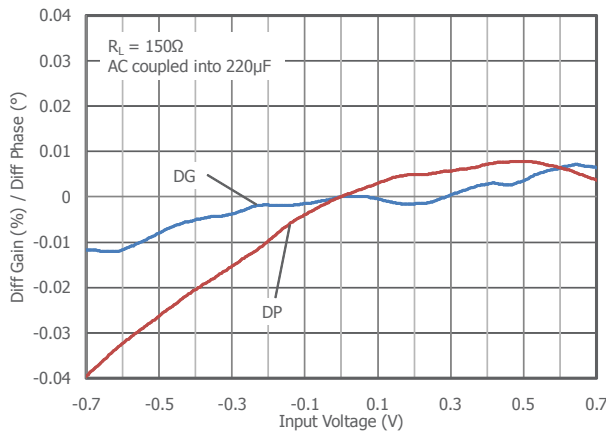

#### Differential Gain & Phase DC Coupled

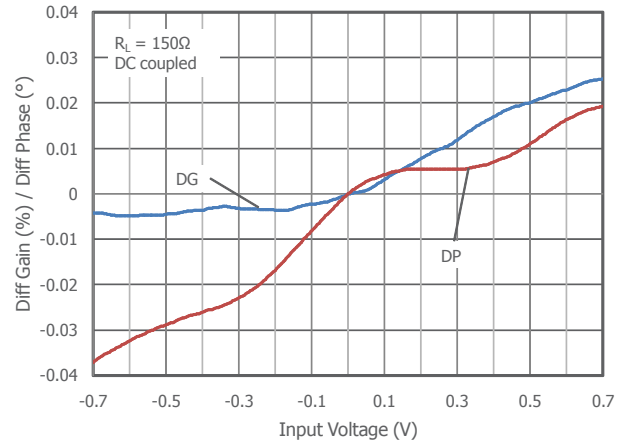



## General Information - Current Feedback Technology

### Advantages of CFB Technology

The CLCx600 Family of amplifiers utilize current feedback (CFB) technology to achieve superior performance. The primary advantage of CFB technology is higher slew rate performance when compared to voltage feedback (VFB) architecture. High slew rate contributes directly to better large signal pulse response, full power bandwidth, and distortion.

CFB also alleviates the traditional trade-off between closed loop gain and usable bandwidth that is seen with a VFB amplifier. With CFB, the bandwidth is primarily determined by the value of the feedback resistor,  $R_f$ . By using optimum feedback resistor values, the bandwidth of a CFB amplifier remains nearly constant with different gain configurations.

When designing with CFB amplifiers always abide by these basic rules:

- Use the recommended feedback resistor value
- Do not use reactive (capacitors, diodes, inductors, etc.) elements in the direct feedback path
- Avoid stray or parasitic capacitance across feedback resistors
- Follow general high-speed amplifier layout guidelines
- Ensure proper precautions have been made for driving capacitive loads

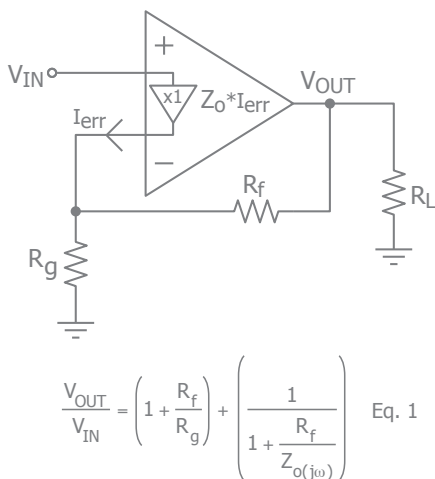

Figure 1. Non-Inverting Gain Configuration with First Order Transfer Function

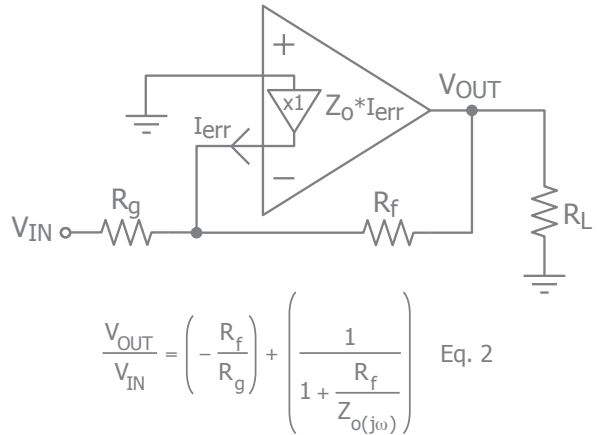

Figure 2. Inverting Gain Configuration with First Order Transfer Function

### CFB Technology - Theory of Operation

Figure 1 shows a simple representation of a current feedback amplifier that is configured in the traditional non-inverting gain configuration.

Instead of having two high-impedance inputs similar to a VFB amplifier, the inputs of a CFB amplifier are connected across a unity gain buffer. This buffer has a high impedance input and a low impedance output. It can source or sink current ( $I_{err}$ ) as needed to force the non-inverting input to track the value of  $V_{in}$ . The CFB architecture employs a high gain trans-impedance stage that senses  $I_{err}$  and drives the output to a value of  $(Z_o(j\omega) * I_{err})$  volts. With the application of negative feedback, the amplifier will drive the output to a voltage in a manner which tries to drive  $I_{err}$  to zero. In practice, primarily due to limitations on the value of  $Z_o(j\omega)$ ,  $I_{err}$  remains a small but finite value.

A closer look at the closed loop transfer function (Eq.1) shows the effect of the trans-impedance,  $Z_o(j\omega)$  on the gain of the circuit. At low frequencies where  $Z_o(j\omega)$  is very large with respect to  $R_f$ , the second term of the equation approaches unity, allowing  $R_f$  and  $R_g$  to set the gain. At higher frequencies, the value of  $Z_o(j\omega)$  will roll off, and the effect of the secondary term will begin to dominate. The -3dB small signal parameter specifies the frequency where the value  $Z_o(j\omega)$  equals the value of  $R_f$  causing the gain to drop by 0.707 of the value at DC.

For more information regarding current feedback amplifiers, visit [www.cadeca.com](http://www.cadeca.com) for detailed application notes, such as AN-3: *The Ins and Outs of Current Feedback Amplifiers*.



## Application Information

### Basic Operation

Figures 3, 4, and 5 illustrate typical circuit configurations for non-inverting, inverting, and unity gain topologies for dual supply applications. They show the recommended bypass capacitor values and overall closed loop gain equations.

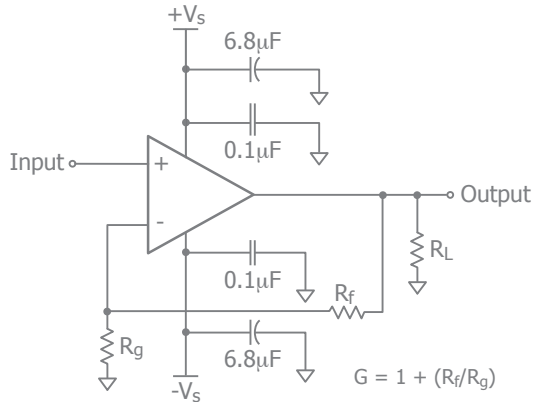

Figure 3. Typical Non-Inverting Gain Circuit

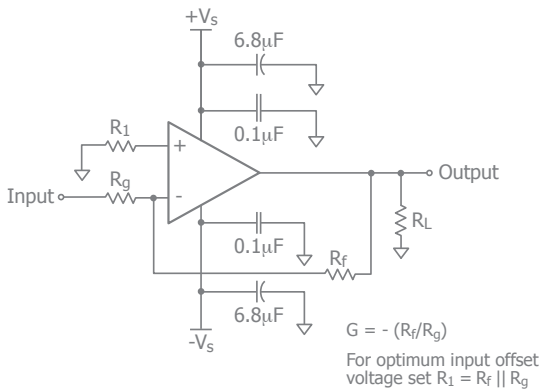

Figure 4. Typical Inverting Gain Circuit

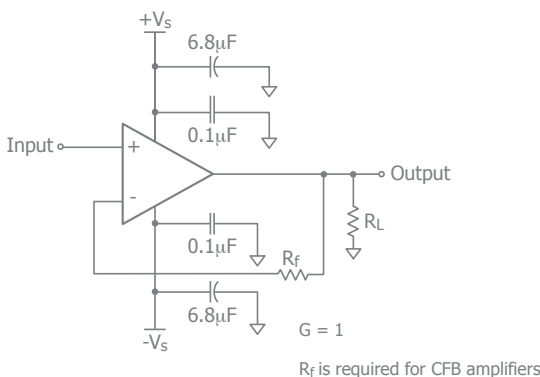

Figure 5. Typical Unity Gain (G=1) Circuit

CFB amplifiers can be used in unity gain configurations. Do not use the traditional voltage follower circuit, where the output is tied directly to the inverting input. With a CFB amplifier, a feedback resistor of appropriate value must be used to prevent unstable behavior. Refer to figure 5 and Table 1. Although this seems cumbersome, it does allow a degree of freedom to adjust the passband characteristics.

### Feedback Resistor Selection

One of the key design considerations when using a CFB amplifier is the selection of the feedback resistor,  $R_f$ .  $R_f$  is used in conjunction with  $R_g$  to set the gain in the traditional non-inverting and inverting circuit configurations. Refer to figures 3 and 4. As discussed in the Current Feedback Technology section, the value of the feedback resistor has a pronounced effect on the frequency response of the circuit.

Table 1, provides recommended  $R_f$  and associated  $R_g$  values for various gain settings. These values produce the optimum frequency response, maximum bandwidth with minimum peaking. Adjust these values to optimize performance for a specific application. The typical performance characteristics section includes plots that illustrate how the bandwidth is directly affected by the value of  $R_f$  at various gain settings.

| Gain (V/V) | $R_f$ ( $\Omega$ ) | $R_g$ ( $\Omega$ ) | $\pm 0.1$ dB BW (MHz) | -3dB BW (MHz) |
|------------|--------------------|--------------------|-----------------------|---------------|
| 1          | 1240               | -                  | 129                   | 300           |
| 2          | 510                | 510                | 140                   | 230           |
| 5          | 200                | 50                 | 18                    | 111           |

Table 1: Recommended  $R_f$  vs. Gain

In general, lowering the value of  $R_f$  from the recommended value will extend the bandwidth at the expense of additional high frequency gain peaking. This will cause increased overshoot and ringing in the pulse response characteristics. Reducing  $R_f$  too much will eventually cause oscillatory behavior.

Increasing the value of  $R_f$  will lower the bandwidth. Lowering the bandwidth creates a flatter frequency response and improves 0.1dB bandwidth performance. This is important in applications such as video. Further increase in  $R_f$  will cause premature gain rolloff and adversely affect gain flatness.



### Driving Capacitive Loads

Increased phase delay at the output due to capacitive loading can cause ringing, peaking in the frequency response, and possible unstable behavior. Use a series resistance,  $R_S$ , between the amplifier and the load to help improve stability and settling performance. Refer to Figure 6.

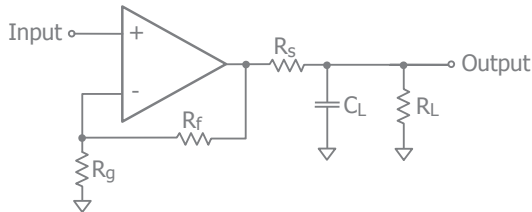

Figure 6. Addition of  $R_S$  for Driving Capacitive Loads

Table 2 provides the recommended  $R_S$  for various capacitive loads. The recommended  $R_S$  values result in  $\leq 0.5\text{dB}$  peaking in the frequency response. The Frequency Response vs.  $C_L$  plot, on page 5, illustrates the response of the CLCx600 Family.

| $C_L$ (pF) | $R_S$ ( $\Omega$ ) | -3dB BW (MHz) |
|------------|--------------------|---------------|
| 10         | 40                 | 265           |
| 50         | 30                 | 140           |
| 100        | 20                 | 105           |

Table 1: Recommended  $R_S$  vs.  $C_L$

For a given load capacitance, adjust  $R_S$  to optimize the tradeoff between settling time and bandwidth. In general, reducing  $R_S$  will increase bandwidth at the expense of additional overshoot and ringing.

### Parasitic Capacitance on the Inverting Input

Physical connections between components create unintentional or parasitic resistive, capacitive, and inductive elements.

Parasitic capacitance at the inverting input can be especially troublesome with high frequency amplifiers. A parasitic capacitance on this node will be in parallel with the gain setting resistor  $R_f$ . At high frequencies, its impedance can begin to raise the system gain by making  $R_g$  appear smaller.

In general, avoid adding any additional parasitic capacitance at this node. In addition, stray capacitance across the  $R_f$  resistor can induce peaking and high frequency

ringing. Refer to the **Layout Considerations** section for additional information regarding high speed layout techniques.

### Overdrive Recovery

An overdrive condition is defined as the point when either one of the inputs or the output exceed their specified voltage range. Overdrive recovery is the time needed for the amplifier to return to its normal or linear operating point. The recovery time varies, based on whether the input or output is overdriven and by how much the range is exceeded. The CLCx600 Family will typically recover in less than 10ns from an overdrive condition. Figure 7 shows the CLC2600 in an overdriven condition.

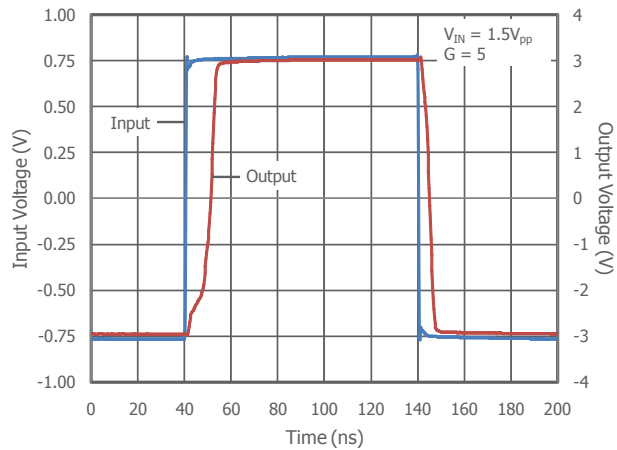

Figure 7. Overdrive Recovery

### Power Dissipation

For most applications, the power dissipation due to driving external loads should be low enough to ensure a safe operating condition. However, applications with low impedance, DC coupled loads should be analyzed to ensure that maximum allowed junction temperature is not exceeded. Guidelines listed below can be used to verify that the particular application will not cause the device to operate beyond its intended operating range.

Maximum power levels are set by the absolute maximum junction rating of 150°C. To calculate the junction temperature, the package thermal resistance value  $\Theta_{JA}$  ( $\Theta_{JA}$ ) is used along with the total die power dissipation.

$$T_{\text{Junction}} = T_{\text{Ambient}} + (\Theta_{JA} \times P_D)$$

Where  $T_{\text{Ambient}}$  is the temperature of the working environment.

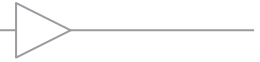

In order to determine  $P_D$ , the power dissipated in the load needs to be subtracted from the total power delivered by the supplies.

$$P_D = P_{\text{supply}} - P_{\text{load}}$$

Supply power is calculated by the standard power equation.

$$P_{\text{supply}} = V_{\text{supply}} \times I_{\text{RMS supply}}$$

$$V_{\text{supply}} = V_{S+} - V_{S-}$$

Power delivered to a purely resistive load is:

$$P_{\text{load}} = ((V_{\text{LOAD}})_{\text{RMS}})^2 / R_{\text{load eff}}$$

The effective load resistor ( $R_{\text{load eff}}$ ) will need to include the effect of the feedback network. For instance,

$R_{\text{load eff}}$  in figure 3 would be calculated as:

$$R_L \parallel (R_f + R_g)$$

These measurements are basic and are relatively easy to perform with standard lab equipment. For design purposes however, prior knowledge of actual signal levels and load impedance is needed to determine the dissipated power. Here,  $P_D$  can be found from

$$P_D = P_{\text{Quiescent}} + P_{\text{Dynamic}} - P_{\text{Load}}$$

Quiescent power can be derived from the specified  $I_S$  values along with known supply voltage,  $V_{\text{Supply}}$ . Load power can be calculated as above with the desired signal amplitudes using:

$$(V_{\text{LOAD}})_{\text{RMS}} = V_{\text{PEAK}} / \sqrt{2}$$

$$(I_{\text{LOAD}})_{\text{RMS}} = (V_{\text{LOAD}})_{\text{RMS}} / R_{\text{load eff}}$$

The dynamic power is focused primarily within the output stage driving the load. This value can be calculated as:

$$P_{\text{DYNAMIC}} = (V_{S+} - V_{\text{LOAD}})_{\text{RMS}} \times (I_{\text{LOAD}})_{\text{RMS}}$$

Assuming the load is referenced in the middle of the power rails or  $V_{\text{supply}}/2$ .

Figure 8 shows the maximum safe power dissipation in the package vs. the ambient temperature for the 8 and 14 lead SOIC packages.

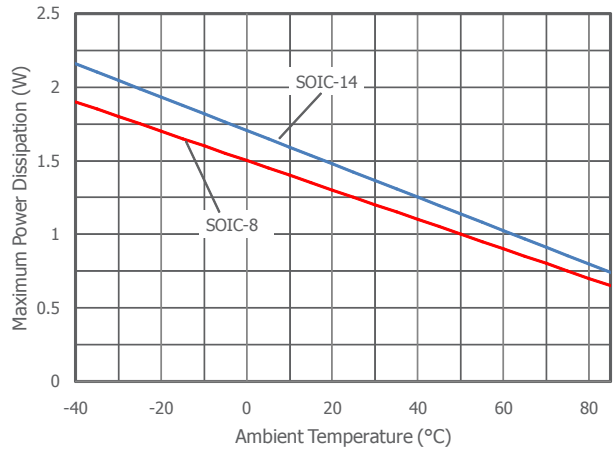

Figure 8. Maximum Power Derating

Better thermal ratings can be achieved by maximizing PC board metallization at the package pins. However, be careful of stray capacitance on the input pins.

In addition, increased airflow across the package can also help to reduce the effective  $\Theta_{JA}$  of the package.

In the event the outputs are momentarily shorted to a low impedance path, internal circuitry and output metallization are set to limit and handle up to 65mA of output current. However, extended duration under these conditions may not guarantee that the maximum junction temperature (+150°C) is not exceeded.

### Layout Considerations

General layout and supply bypassing play major roles in high frequency performance. CADEKA has evaluation boards to use as a guide for high frequency layout and as aid in device testing and characterization. Follow the steps below as a basis for high frequency layout:

- Include 6.8μF and 0.1μF ceramic capacitors for power supply decoupling
- Place the 6.8μF capacitor within 0.75 inches of the power pin
- Place the 0.1μF capacitor within 0.1 inches of the power pin
- Remove the ground plane under and around the part, especially near the input and output pins to reduce parasitic capacitance
- Minimize all trace lengths to reduce series inductances

Refer to the evaluation board layouts below for more information.

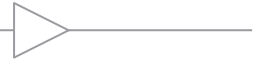

Evaluation Board Information

The following evaluation boards are available to aid in the testing and layout of these devices:

| Evaluation Board | Products         |
|------------------|------------------|
| CEB006           | CLC2600          |
| CEB018           | CLC3600, CLC4600 |

Evaluation Board Schematics

Evaluation board schematics and layouts are shown in Figures 9-14. These evaluation boards are built for dual-supply operation. Follow these steps to use the board in a single-supply application:

1. Short -Vs to ground.
2. Use C3 and C4, if the -Vs pin of the amplifier is not directly connected to the ground plane.

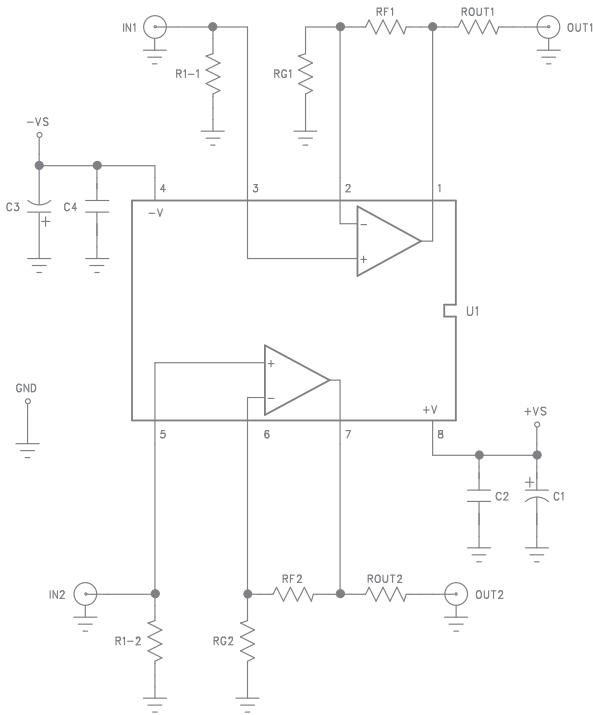

Figure 9. CEB006 Schematic

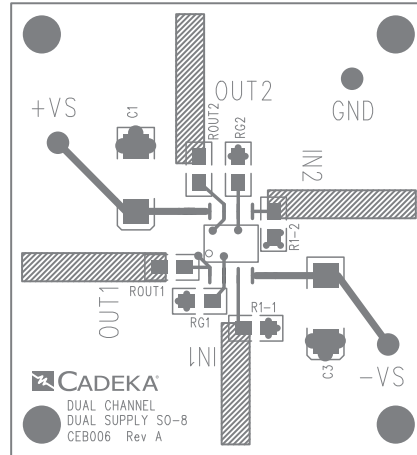

Figure 10. CEB006 Top View

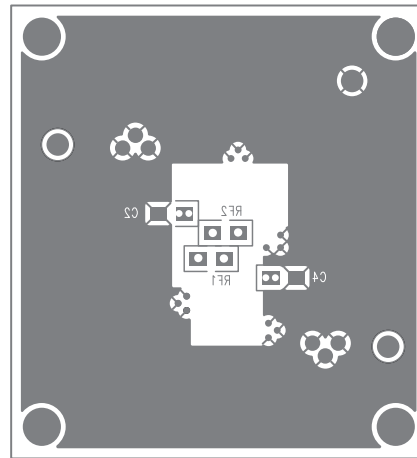

Figure 11. CEB006 Bottom View

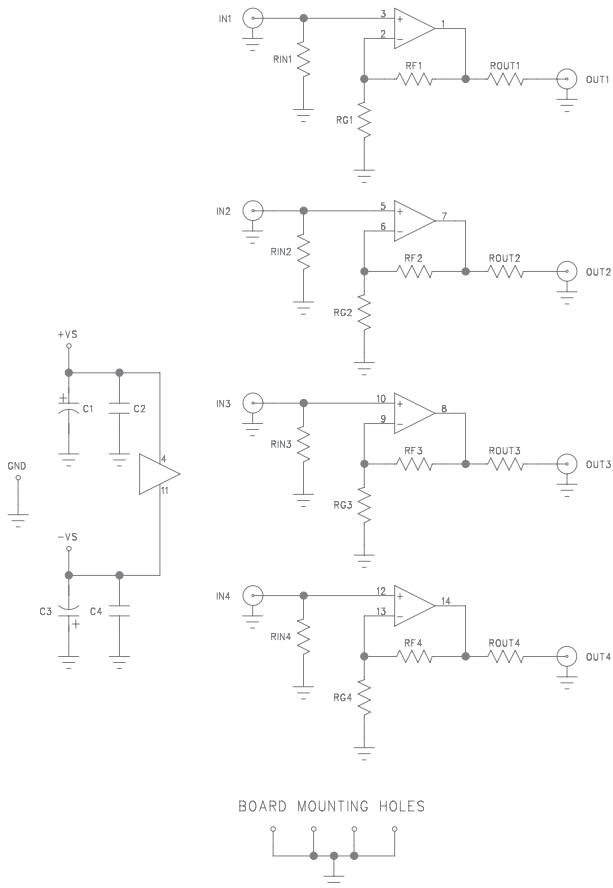
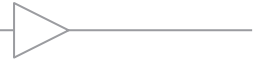

Figure 12. CEB018 Schematic

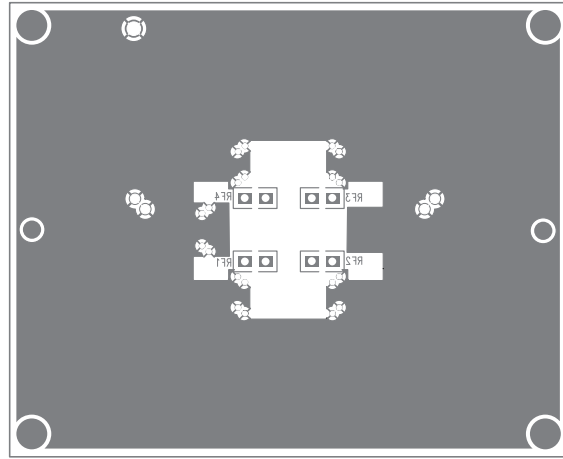

Figure 14. CEB018 Bottom View

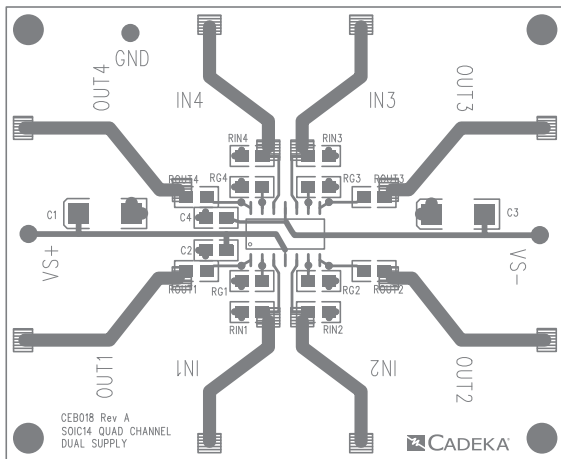
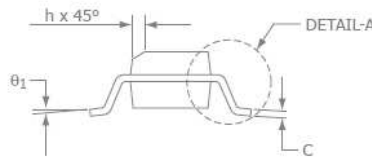
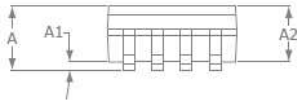
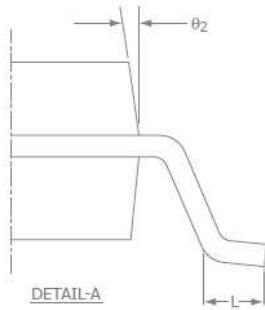
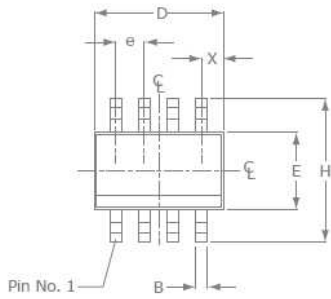

Figure 13. CEB018 Top View



## Mechanical Dimensions

### SOIC-8 Package



| SOIC-8             |          |      |
|--------------------|----------|------|
| SYMBOL             | MIN      | MAX  |
| A1                 | 0.10     | 0.25 |
| B                  | 0.36     | 0.48 |
| C                  | 0.19     | 0.25 |
| D                  | 4.80     | 4.98 |
| E                  | 3.81     | 3.99 |
| e                  | 1.27 BSC |      |
| H                  | 5.80     | 6.20 |
| h                  | 0.25     | 0.5  |
| L                  | 0.41     | 1.27 |
| A                  | 1.37     | 1.73 |
| theta <sub>1</sub> | 0°       | 8°   |
| X                  | 0.55 ref |      |
| theta <sub>2</sub> | 7° BSC   |      |

**NOTE:**

1. All dimensions are in millimeters.
2. Lead coplanarity should be 0 to 0.1mm (0.004") max.
3. Package surface finishing: VDI 24~27
4. All dimension excluding mold flashes.
5. The lead width, B to be determined at 0.1905mm from the lead tip.

### SOIC-14 Package

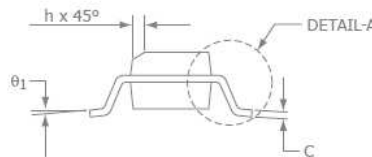
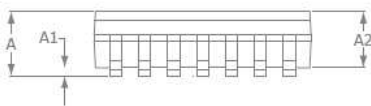
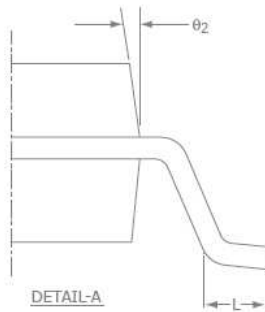
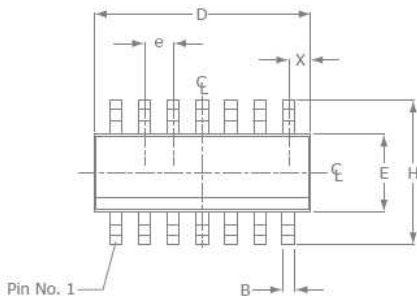

| SOIC-14            |          |      |
|--------------------|----------|------|
| SYMBOL             | MIN      | MAX  |
| A1                 | 0.10     | 0.25 |
| B                  | 0.36     | 0.48 |
| C                  | 0.19     | 0.25 |
| D                  | 8.56     | 8.74 |
| E                  | 3.84     | 3.99 |
| e                  | 1.27 BSC |      |
| H                  | 5.80     | 6.20 |
| h                  | 0.25     | 0.5  |
| L                  | 0.41     | 1.27 |
| A                  | 1.37     | 1.73 |
| theta <sub>1</sub> | 0°       | 8°   |
| X                  | 0.51 ref |      |
| theta <sub>2</sub> | 7° BSC   |      |

**NOTE:**

1. All dimensions are in millimeters.
2. Lead coplanarity should be 0 to 0.1mm (0.004") max.
3. Package surface finishing: VDI 24~27
4. All dimension excluding mold flashes.
5. The lead width, B to be determined at 0.1905mm from the lead tip.

For additional information regarding our products, please visit CADEKA at: [cadeka.com](http://cadeka.com)

**CADEKA Headquarters** Loveland, Colorado  
 T: 970.663.5452  
 T: 877.663.5452 (toll free)

CADEKA, the CADEKA logo design, and Comlinear and the Comlinear logo design, are trademarks or registered trademarks of CADEKA Microcircuits LLC. All other brand and product names may be trademarks of their respective companies.

CADEKA reserves the right to make changes to any products and services herein at any time without notice. CADEKA does not assume any responsibility or liability arising out of the application or use of any product or service described herein, except as expressly agreed to in writing by CADEKA; nor does the purchase, lease, or use of a product or service from CADEKA convey a license under any patent rights, copyrights, trademark rights, or any other of the intellectual property rights of CADEKA or of third parties.

Copyright ©2007-2010 by CADEKA Microcircuits LLC. All rights reserved.

