



Model Number AC-A60VDI2H5.0

Type: Constant Voltage LED Driver
 Input Voltage: 120-277V
 Input Frequency: 50/60Hz



ELECTRICAL SPECIFICATIONS:

Output Power	Input Current	Minimum PF (full load)	Max. THD (full load)	Output Voltage	Output Current	T case Maximum	Minimum Starting Temp.	Efficiency Up To	Dimming Protocol	Dimming Range	IP Rating
60W	0.61A @ 120V 0.27A @ 277V	>0.95	<10%	12V ±5%	0.5 to 5A	90° C	-40° C	83.7%	0 - 10V	100% - 10%	IP66

WIRING:

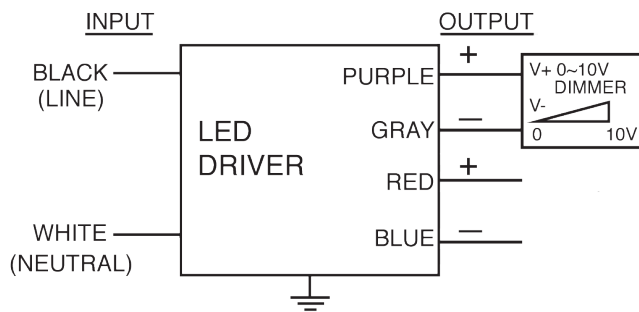

Lead Lengths					
Black	5.9"	Blue	5.9"	Purple	9.8"
White	5.9"	Red	5.9"	Gray	9.8"

PHYSICAL:



Dimensions	
Length	9.5"
Width	1.7"
Height	1.14"
Mounting Length	8.9"
Mounting Hole Distance	1.0"
Mounting Hole Diameter	.20"
Weight	1.32 lbs.
Case Qty.	30 pcs.

SAFETY:

- UL and cUL Recognized
- UL1310 Class 2
- UL Outdoor Type I
- Class A sound rating
- Overload Protection
- Open/Short Circuit Protection
- LED driver has a life expectancy of 50,000 hours at Tcase of ≤75°C
- LED driver has a life expectancy of 100,000 hours at Tcase of ≤65°C
- Warranty: 5 yrs based on max case temp of <75°C; 3 yrs based on max case temp of 90°C*
- Input/Output Isolation
- FCC Title 47 CFR Part 15
- Surge Protection (2 KV)

INSTALLATION:

- LED drivers shall be installed inside electrical enclosures
- 18 AWG 600V/105C tinned strand copper lead-wires are required to use in installation
- Max Remote installation distance is 18 ft
- LED driver cases should be grounded



*A.C.E. warrants to the purchaser that each LED Driver will be free from defects in material or workmanship for a period of 5 years when operated at max case temp of up to <75°C; 3 years from date of manufacture when operated at a max case temp of up to 90°C when properly installed and under normal conditions of use. See www.aceleds.com for complete warranty policy.

3401 Avenue D, Arlington, TX 76011 • 800-375-6355 • www.aceleds.com

Data is based upon tests performed by AC Electronics in a controlled environment and representative performance. Actual performance can vary depending on operating conditions. Specifications are subject to change without notice. All specifications are nominal unless otherwise noted.