

## FEATURES

- 40 - 800 MHz
- SPACE Application
- Hermetic Package
- Surface Mount
- Radiation Tolerant, 100 K Rad



**MODEL NO.  
CAT15066**

**GaAs 6 Section Attenuator**

6 BIT

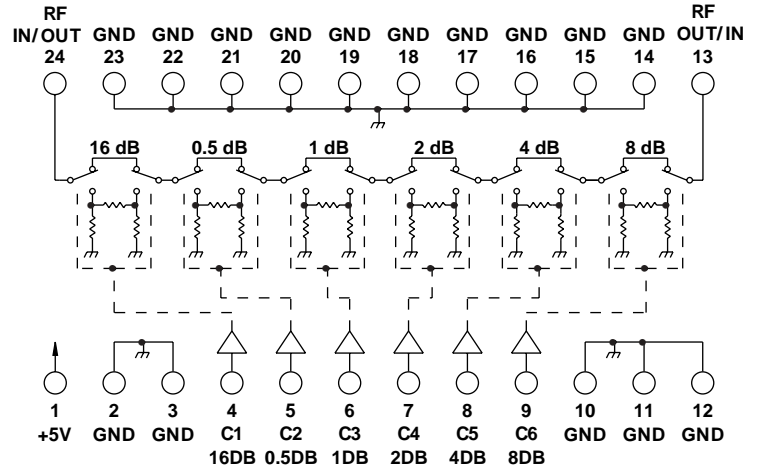
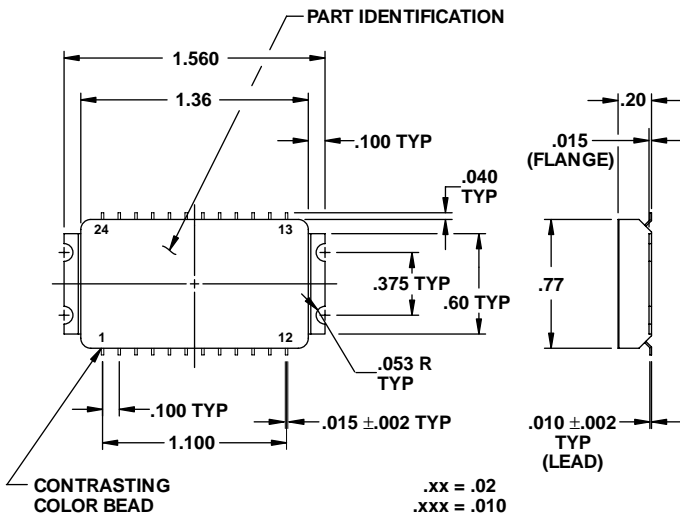

## GUARANTEED PERFORMANCE

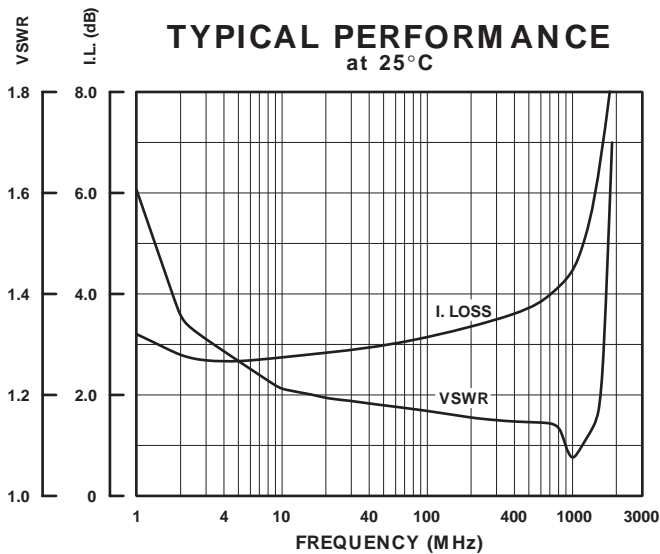

Parameter	Min	Typ	Max	Units	Conditions
Operating Frequency	40		800	MHz	
DC Current		1	5	mA	At +5 VDC Supply
Control Type		CMOS			6 Line Logic "0" = Thru Logic "1" = Attenuation
Control Current	High Low	0 0	±40 ±40	µA	3 - 5 Volts 0 - 0.5 Volts
Insertion Loss		4.2 6.3	5.5 7.5	dB	40 - 100 MHz 100 - 800 MHz
Attenuation	LSB Range Accuracy Flatness	0	0.5 31.5	dB	0.5, 1, 2, 4, 8, 16 ± (0.25 dB + 2% of Atten Setting in dB)
VSWR		1.18/1	1.3/1		
Impedance		50		OHMS	
Switching Speed		22	50	nSec	50% Control Signal 90% / 10% RF
Transition (Rise/Fall) Time		8		nSec	10% / 90% or 90% / 10% RF
Switching (Video) Transients		110		mV	Peak Value
Intercept Points	2nd 3rd	+61 +34	+66 +42	dBm	70 / 50 MHz Inputs 90 / 50 MHz Inputs
RF Power	Operate No Damage		+23 +27	dBm	0.1 dB Compression
Operating Temperature		0	+25	+65	°C TA
Non-Operating Temperature		-34		+95	°C TA