

FEATURES

- 200 - 600 MHz
- SPACE Application
- Hermetic Package
- Radiation Tolerant, 100 K Rad
- Surface Mount



MODEL NO.
CAT58054

GaAs 5 Section Attenuator

5 BIT

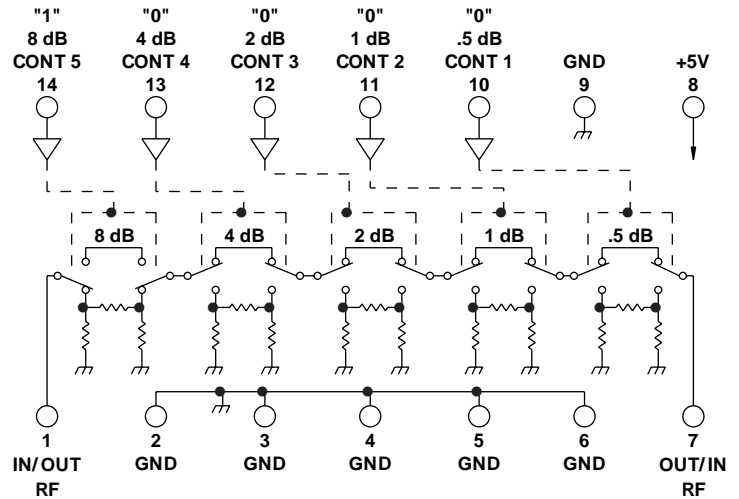
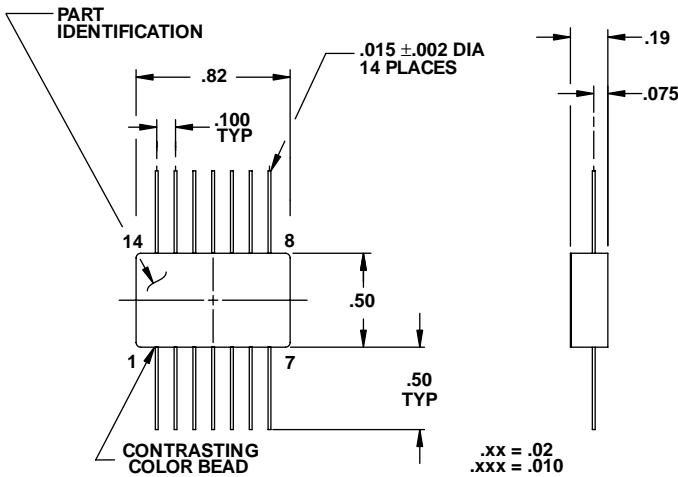

GUARANTEED PERFORMANCE

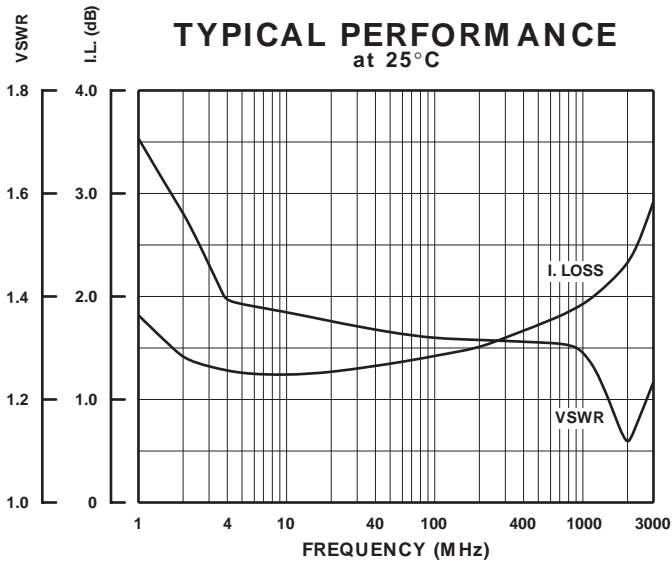

Parameter	Min	Typ	Max	Units	Conditions
Operating Frequency	200		600	MHz	
DC Current		0.7	2.0	mA	At +5 VDC Supply
Control Type		CMOS			5 Line Logic "0" = Thru Logic "1" = Attenuation
Control Current	High Low	1 1	±20 ±20	µA	3 - 5 Volts 0 - 0.5 Volts
Insertion Loss		1.71	2.5	dB	
Insertion Loss Flatness			±0.2	dB	Vs. Frequency
Attenuation	LSB Range Accuracy Flatness	0	0.5 15.5	dB dB	0.5, 1, 2, 4, 8 + 0.15 dB + 3% of Atten Setting in dB - 0.35 dB - 3% of Atten Setting in dB
VSWR		1.33/1	1.6/1		
Impedance		50		OHMS	
Switching Speed		14	50	nSec	50% Control Signal 90% / 10% RF
Transition (Rise/Fall) Time		12		nSec	10% / 90% or 90% / 10% RF
Switching (Video) Transients		84		mV	Peak Value
Intercept Points	2nd 3rd	+45 +34	+56 +37	dBm dBm	70 / 50 MHz Inputs 35 / 50 MHz Inputs
RF Power	Operate No Damage		+12 +23	dBm dBm	0.1 dB Compression
Operating Temperature		0	+25	+65	°C TA
Non-Operating Temperature		-34		+95	°C TA