

FEATURES

- 1800 - 4200 MHz
- SPACE Application
- Hermetic Package
- Radiation Tolerant, 100 K Rad
- Surface Mount

4 BIT



MODEL NO.
CAT48049

GaAs 4 Section Attenuator

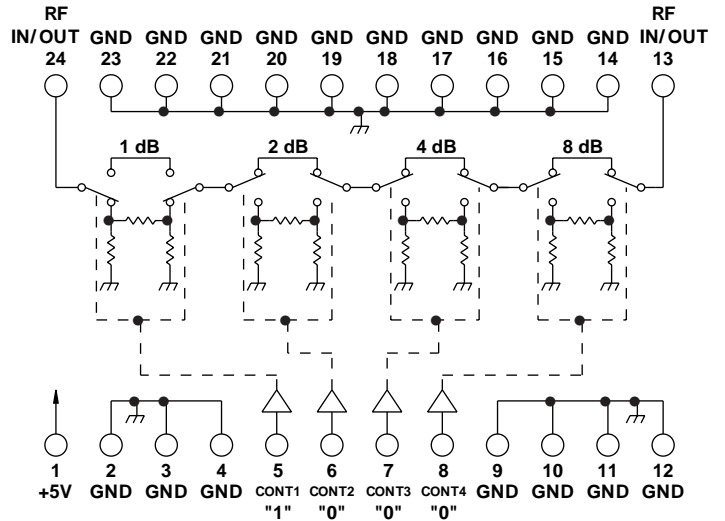
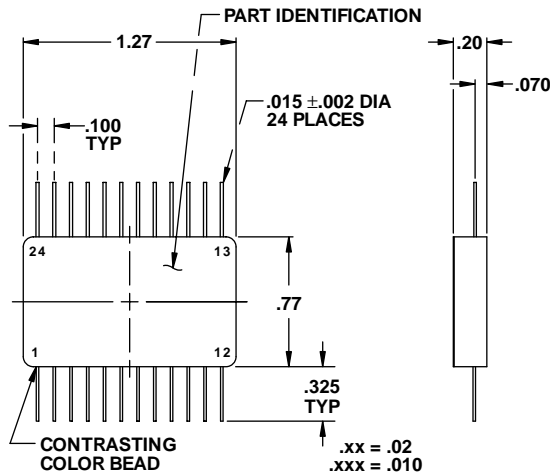

GUARANTEED PERFORMANCE

Parameter	Min	Typ	Max	Units	Conditions
Operating Frequency	1800		4200	MHz	
DC Current		0.8	5.0	mA	At +5 VDC Supply
Control Type		CMOS			4 Line Logic "0" = Thru Logic "1" = Attenuation
Control Current		0	±40	µA	3 - 5 Volts
		0	±40	µA	0 - 0.5 Volts
Insertion Loss		5.0	6.0	dB	
Insertion Loss Flatness			±0.2	dB	Vs. Frequency
Attenuation		1	15	dB	1, 2, 4, 8
		0		dB	±(0.25 dB + 5% of Atten Setting in dB)
			±0.2	dB	Flatness
VSWR		1.30/1	1.7/1		
Impedance		50		OHMS	
Switching Speed		27	50	nSec	50% Control Signal 90% / 10% RF
Transition (Rise/Fall) Time		12		nSec	10% / 90% or 90% / 10% RF
Switching (Video) Transients		75		mV	Peak Value
Intercept Points		+67	+70	dBm	1950 / 750 MHz Inputs
		+38	+41	dBm	975 / 750 MHz Inputs
RF Power		+22	+18	dBm	0.1 dB Compression
			+23	dBm	
Operating Temperature	0	+25	+65	°C	TA
Non-Operating Temperature	-34		+95	°C	TA

