

FEATURES

- 100 - 2000 MHz
- SPACE Application
- Hermetic Package
- Radiation Tolerant, 100 K Rad
- Surface Mount

4 BIT



MODEL NO.
CAT48053

GaAs 4 Section Attenuator

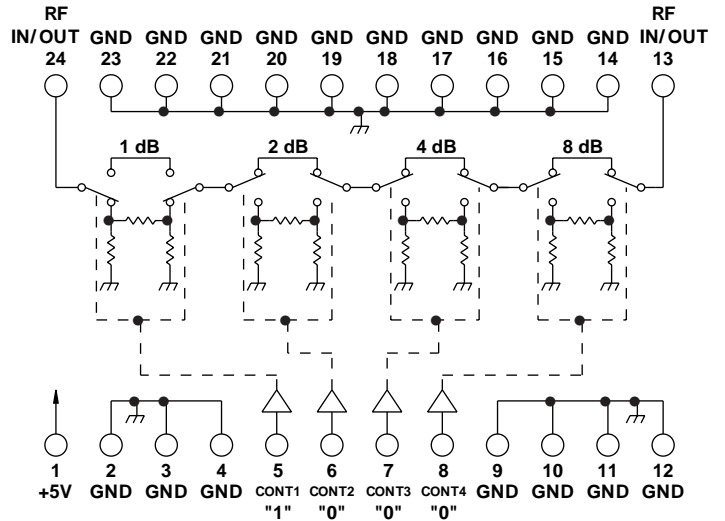
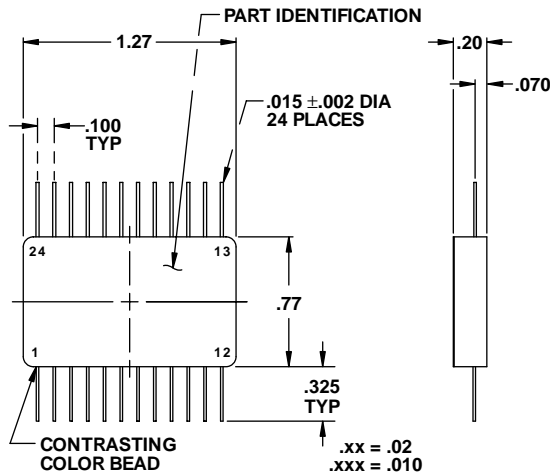

GUARANTEED PERFORMANCE

Parameter	Min	Typ	Max	Units	Conditions
Operating Frequency	100		2000	MHz	
DC Current		0.3	5.0	mA	At +5 VDC Supply
Control Type		CMOS			4 Line Logic "0" = Thru Logic "1" = Attenuation
Control Current		±1	±40	µA	3 - 5 Volts
		±1	±40	µA	0 - 0.5 Volts
Insertion Loss		3.4	4.0	dB	
Insertion Loss Flatness			±0.2	dB	Vs. Frequency
Attenuation		1	15	dB	1, 2, 4, 8
	LSB Range Accuracy	0		dB	±(0.25 dB + 2% of Atten Setting in dB)
	Flatness	±0.05	±0.2	dB	
VSWR		1.3/1	1.7/1		
Impedance		50		OHMS	
Switching Speed		32	50	nSec	50% Control Signal 90% / 10% RF
Transition (Rise/Fall) Time		22		nSec	10% / 90% or 90% / 10% RF
Switching (Video) Transients		34		mV	Peak Value
Intercept Points	2nd	+64	+70	dBm	500 / 350 MHz Inputs
	3rd	+38	+45	dBm	250 / 350 MHz Inputs
RF Power	Operate		+20	dBm	0.1 dB Compression
	No Damage		+10	dBm	
			+25	dBm	
Operating Temperature	0	+25	+65	°C	TA
Non-Operating Temperature	-34		+95	°C	TA

