

MODEL NUMBER DTD05026

Threshold Detector

FEATURES

- 10-2000 MHz
- -25 to -10 dBm Dynamic Range
- Adjustable Threshold Level
- 1 mA Sink/Source Current
- See DTD01904 to TO-8 Version

TD

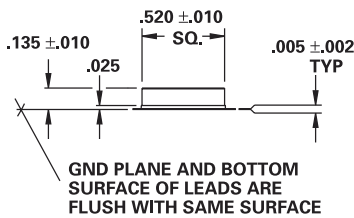
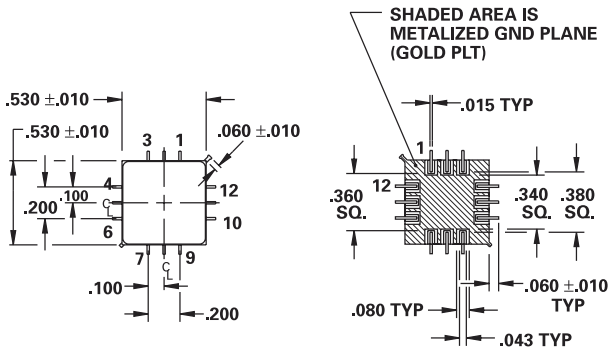

.xx = .02
.xxx = .010

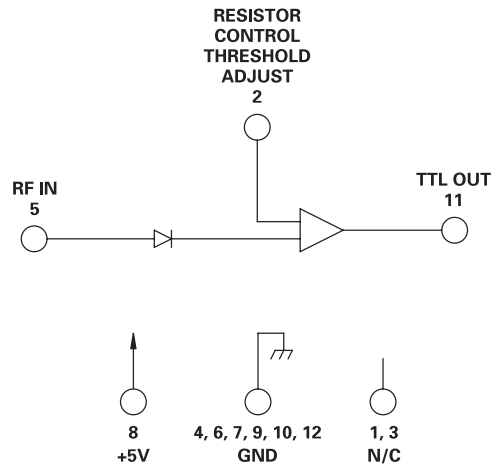

RF INPUT	OUTPUT LOGIC
$P_{IN} < P_{TH}$	"0"
$P_{IN} > P_{TH}$	"1"

TYPICAL PERFORMANCE at 25°C

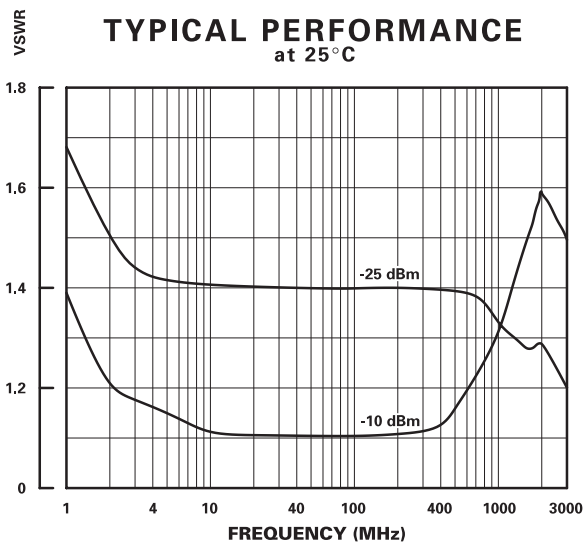

GUARANTEED PERFORMANCE

Parameter	Min	Typ	Max	Units	Conditions
Operating Frequency	10		2000	MHz	
Dynamic Range	-25		-10	dBm	
Hysteresis		0.7	1.2	dB	
Temperature Stability		±0.8	±1.5	dB	
Input Flatness		±0.15	±1.5	dB	
Response Time (See Note)		3.6	5	mSec	@ -10 dBm
Input VSWR		1.5/1	2.0/1		
Output Current:	Source	0.5	1.01	mA	VOH = +2.7V
	Sink	1	9.4	mA	VOL = +0.5V
DC Current		4	5	mA	At +5 VDC
RF Power			+13	dBm	No Damage
Operating Temperature	-55	+25	+85	°C	TA

NOTE1: Transition Time For Input Change > 3 dB Above CW Threshold. Output Loading 1 MΩ and 80 pF.