

MODEL NUMBER
100C1818

Phase Compensated
Linear PIN Diode VCA

- FEATURES**
- 30-150 MHz
 - 40 dB Linear Range
 - Constant Phase vs. Attenuation
 - SMA Connectors

VCA

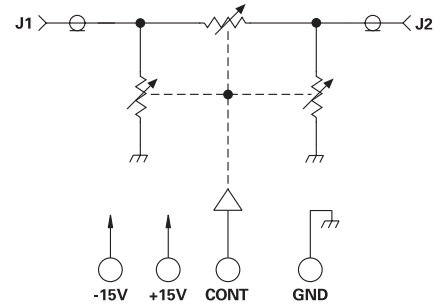
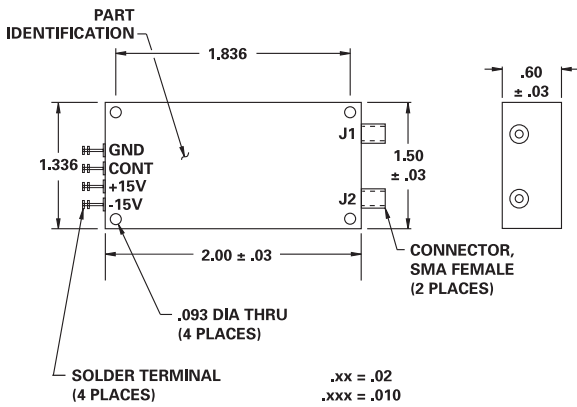

GUARANTEED PERFORMANCE

Parameter	Min	Typ	Max	Units	Conditions
Operating Frequency	30		150	MHz	
DC Current		47	70	mA	At +15 VDC Supply
		43	70	mA	At -15 VDC Supply
Insertion Loss		3	4	dB	
Attenuation	Range	40	50	dB	Best Straight Line Fit From IL +2 dB to 40 dB
	Slope	12	15	dB/V	
	Linearity			±2	
Attenuation vs. Phase		±2.4	±5	DEG	Broadband At 60±5 MHz 25±5° C From 0 to 30 dB Atten.
		±23	±1	DEG	
VSWR		1.25/1	1.35/1		
Impedance		50		OHMS	
Slew Rate		6		dB/μs	
Intercept Points	2nd	+45		dBm	60 MHz / 87 MHz
	3rd	+28		dBm	60 MHz / 43.5 MHz
RF Power	Operate		+10	dBm	0.1 dB Compression
	No Damage		+20	dBm	
Operating Temperature	-55	+25	+85	°C	TA

Note - Control Configuration: 0 to +5 Volts (at 5K Nominal Input Impedance)

