

MODEL NUMBER DA0784-1

GaAs 4 Section Attenuator

FEATURES

- 10- 1000 MHz
- 0.8 mA, +5 VDC
- 1 dB LSB, 15 dB Range
- 20 nSec Switching Speed
- 12 nSec Transition Time
- 48 mV Transients
- TTL Control
- 12 Pin Surface Mount Package
- See DA0984-1 For 12 Pin TO-8 Package

4 BIT

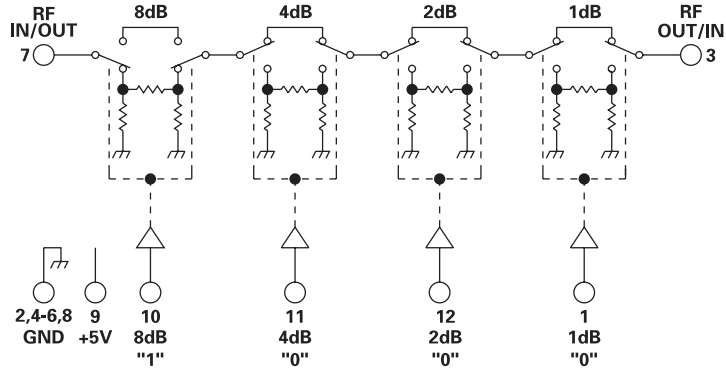
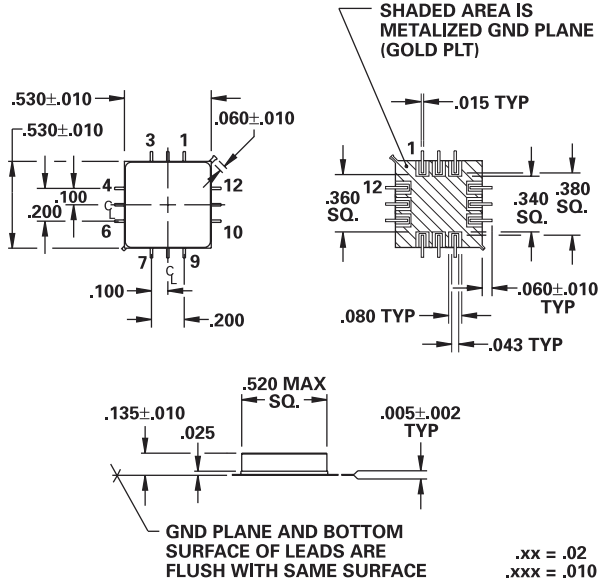

GUARANTEED PERFORMANCE

Parameter	Min	Typ	Max	Units	Conditions
Operating Frequency	10		1000	MHz	
DC Current		0.8	2.0	mA	At +5 VDC Supply
Control Type		TTL			4 Line Logic "0" = Thru Logic "1" = Attenuation
Control Current	High Low	1 1	±20 ±20	µA	V _{IH} = +2.7 Volts V _{IL} = 0.5 Volts
Insertion Loss		1.9	2.5	dB	MHz
Attenuation	LSB Range Accuracy	0	1 15	dB dB dB	1, 2, 4, 8 +0.15 dB +2% of Atten. Setting in dB -0.35 dB +2% of Atten. Setting in dB
VSWR		1.2/1	1.6/1		
Impedance		50		OHMS	
Switching Speed		20	30	nSec	50% TTL - 90% / 10% RF
Transition (Rise/Fall) Time		12		nSec	90% / 10% or 10% / 90% RF
Switching (Video) Transients		48		mV	Peak Value
Intercept Points	2nd 3rd	+54 +38		dBm dBm	70 MHz / 50 MHz 35 MHz / 50 MHz
RF Power	Operate No Damage	+9 +14	+6 +10 +23	dBm dBm dBm	0.1 dB Compression (<50 MHz) 0.1 dB Compression (>50 MHz)
Operating Temperature		-55	+25	+85	°C TA

