

FEATURES

- DC - 2000 MHz
- < 1 mA, ±5 VDC
- 3 dB LSB, 30 dB Range
- 30 nSec Switching Speed
- TTL Control
- 24 Pin DIP



**MODEL NO.
DAT41994**

GaAs 4 Section Attenuator

4 BIT

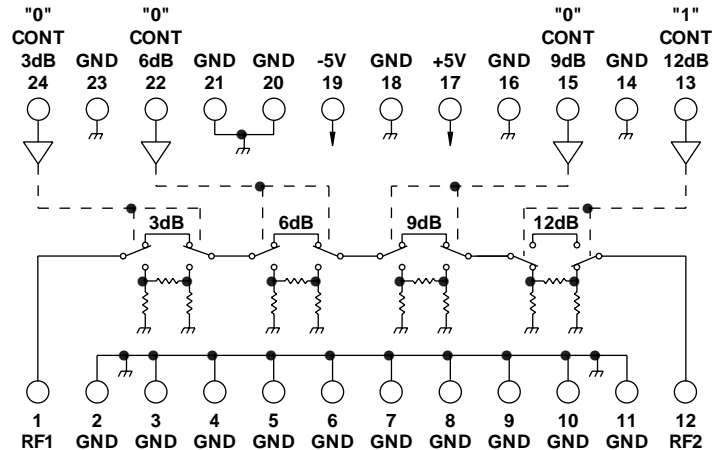
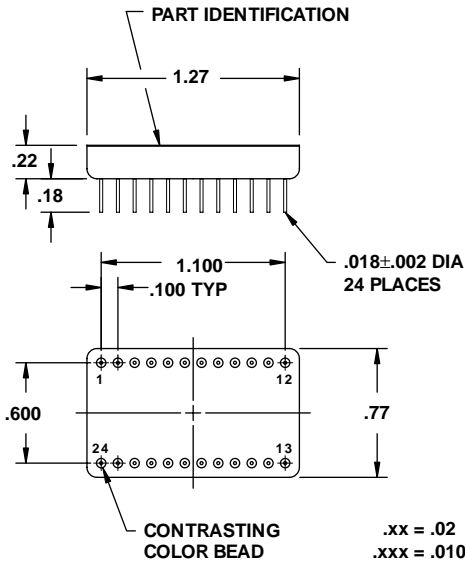

GUARANTEED PERFORMANCE

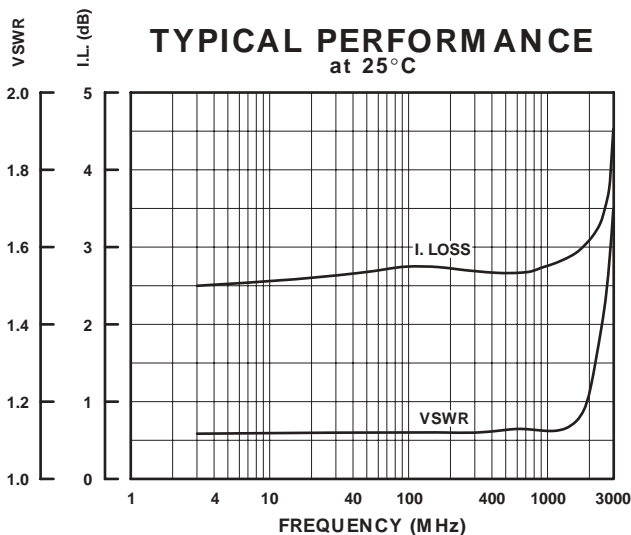

Parameter	Min	Typ	Max	Units	Conditions
Operating Frequency	DC		2000	M Hz	
DC Current		0.53 0.01	30 3	mA mA	At +5 VDC Supply At -5 VDC Supply
Control Type		TTL			4 Line Logic "1" = Attenuation
Control Current	High Low	1.0 1.0	±10 ±10	μA μA	V _{IH} = +5.0 V V _{IL} = 0 V
Insertion Loss		3.1	4.0	dB	
Attenuation	LSB Range Accuracy	0	3 30	dB dB dB	3, 6, 9, 12 ±(0.25 dB +3% of Atten. Setting in dB)
VSWR		1.25/1	1.7/1		
Impedance		50		OHMS	
Switching Speed		30	50	nSec	50% TTL to 90% / 10% RF
Transition (Rise/Fall) Time		10		nSec	90% / 10% or 10% / 90% RF
Switching (Video) Transients		30		mV	Peak Value
Intercept Points	2nd 3rd	+68 +32		dBm dBm	1700 / 700 M Hz 850 / 750 M Hz
RF Power	Operate No Damage	+20 +17	+10 +17	dBm dBm	0.1 dB Compression @ 10 M Hz
Operating Temperature		-55 +25	+125	°C	TA