

**MODEL NUMBER  
DA0760**

**PIN Diode 5 Section Attenuator**

**FEATURES**

- 100-1000 MHz
- 7 mA, + 5 VDC
- 1 dB LSB, 31 dB Range
- TTL Control
- 24 Pin Surface Mount Package

**5 BIT**

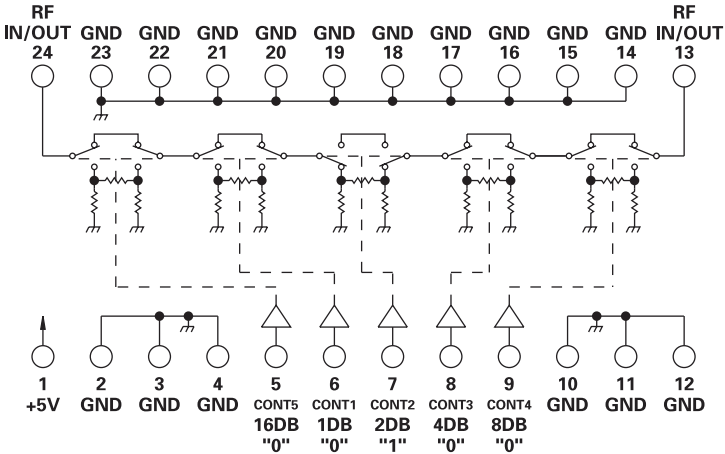
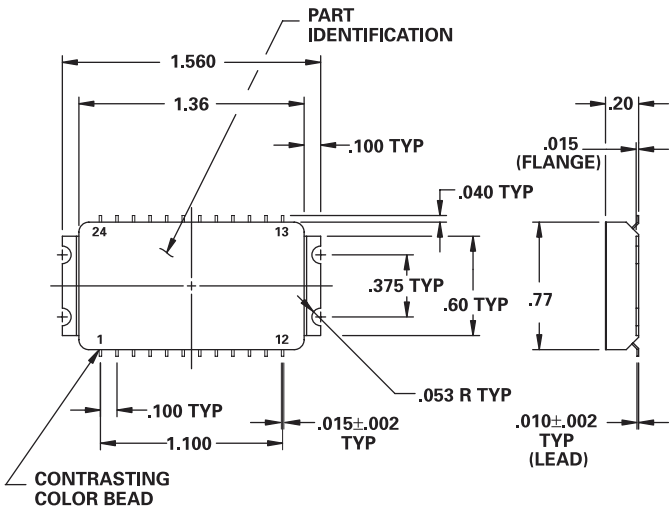

**GUARANTEED PERFORMANCE**

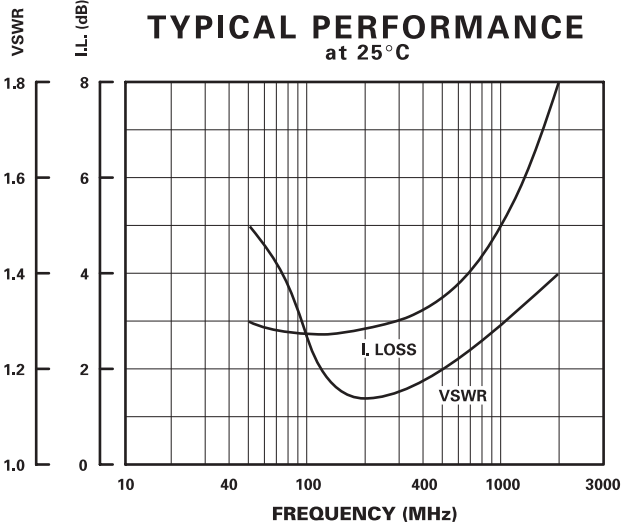

Parameter	Min	Typ	Max	Units	Conditions
Operating Frequency	100		1000	MHz	
DC Current		7	20	mA	At +5 VDC Supply
Control Current	High	1.0	±10	µA	VIH = +2.7 V
	Low	1.0	±10	µA	VIL = +0.5 V
Insertion Loss		4.0	5.0	dB	100 - 500 MHz
			5.0	6.0	dB
Attenuation	LSB		1	dB	
	Range	0		31	dB
	Accuracy				dB
VSWR		1.3/1	1.5/1		
Impedance		50		OHMS	
Switching Speed		2	3	µSec	50% TTL to 90% / 10% RF
Transition (Rise/Fall) Time		250	500	nSec	90% / 10% or 10% / 90% RF
Switching (Video) Transients		100	500	mV	Peak Value
Intercept Points	2nd	+60		dBm	400 MHz / 190 MHz
	3rd	+33		dBm	300 MHz / 390 MHz
RF Power	Operate	+13	+10	dBm	0.1 dB Compression
	No Damage		+27	dBm	
Operating Temperature	-55	+25	+125	°C	TA