

MODEL NUMBER DA0816

GaAs 1 Section Attenuator

FEATURES

- 20-700 MHz
- 0.4 mA, +5 VDC
- 22 nSec Switching Speed
- 10 nSec Rise Time
- 10, 20, or 32 dB Steps
- TTL Driver

1 BIT

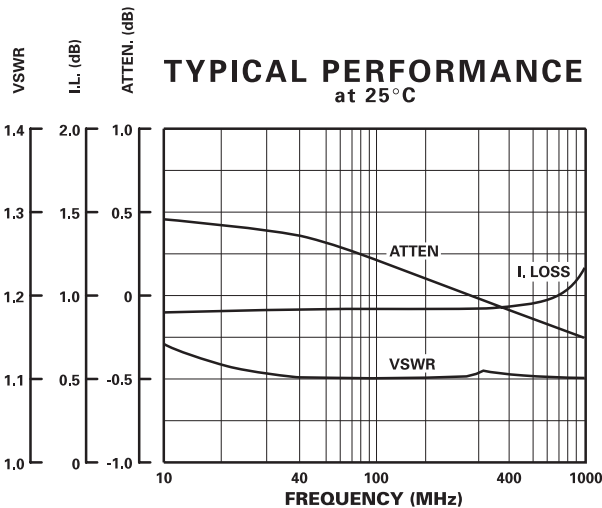
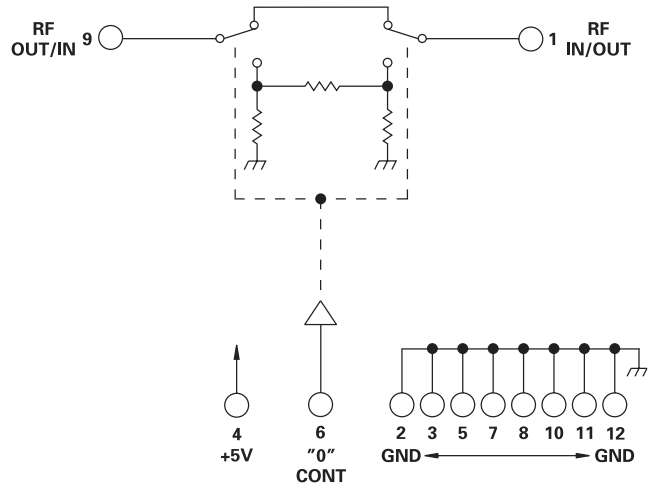
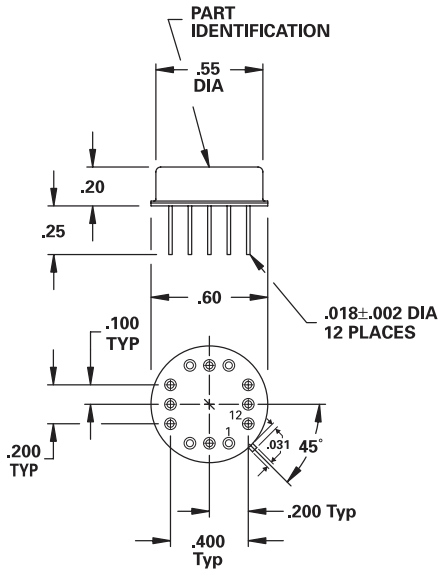

TABULATION CHART	
Part Number	Attenuation
DA0816-32	32 dB
DA0816-20	20 dB
DA0816-10	10 dB
DA0816-11	11 dB

GUARANTEED PERFORMANCE

Parameter	Min	Typ	Max	Units	Conditions
Operating Frequency	20		700	MHz	
DC Current		0.4	1	mA	At +5 VDC Supply
Control Type		TTL			1 Line, Reverse Logic Available Logic "0" = Thru Logic "1" = Attenuation
Control Current	High Low	0 0	±20 ±20	µA	V _{IH} = +3.0 V V _{IL} = +0.5 V
Insertion Loss		1.0	1.5	dB	
Attenuation	LSB Range Accuracy			dB dB dB	See Table See Table ± (0.15 dB + 2% of Atten. Setting in dB)
VSWR		1.1/1	1.25/1		
Impedance		50		OHMS	
Switching Speed		22	35	nSec	50% TTL to 90% / 10% RF
Transition (Rise/Fall) Time		10		nSec	90% / 10% or 10% / 90% RF
Switching (Video) Transients		45		mV	Peak Value
Intercept Points	2nd 3rd	+68 +35		dBm dBm	140 MHz / 200 MHz 140 MHz / 100 MHz
RF Power	Operate No Damage	+12	+10 +27	dBm dBm	0.1 dB Compression
Operating Temperature		-55	+25 +125	°C	TA