

FEATURES

- 10 - 1000 MHz
- 0.1 mA, +5 VDC
- ± 0.1 dB Accuracy
- Constant Phase
- Medium Power
- TTL Driver
- TO-8 Package
- See 100C1711-10 For Connectorized Version



**MODEL NO.
DA0923-10**

GaAs 1 Section Attenuator

1 BIT

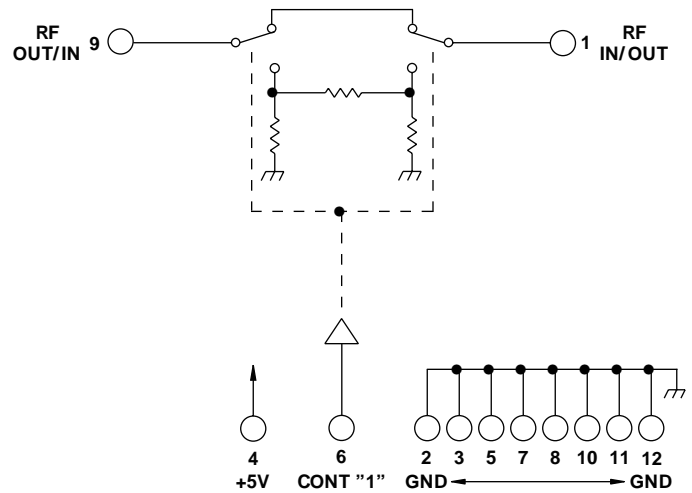
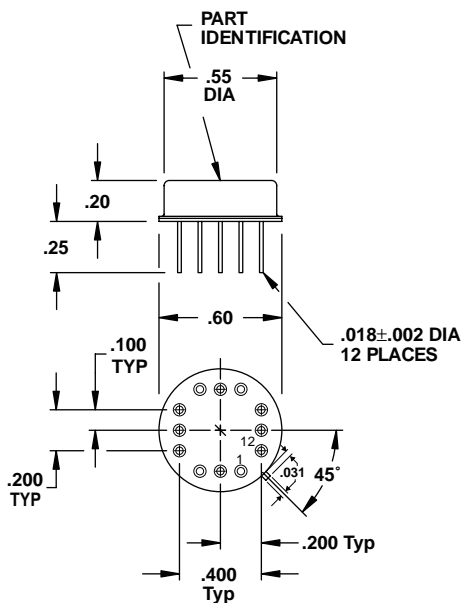

GUARANTEED PERFORMANCE

Parameter	Min	Typ	Max	Units	Conditions	
Operating Frequency	10		1000	MHz		
DC Current		0.1	1	mA	At +5 VDC Supply	
Control Type		TTL			1 Line, Reverse Logic Available Logic "0" = Attenuation Logic "1" = Thru	
Control Current		High Low	0 0	± 20 ± 20	μ A μ A	$V_{IH} = +3.0$ V $V_{IL} = +0.5$ V
Insertion Loss		1.0	1.4	dB	10 - 700 MHz	
		1.2	1.8	dB	700 - 1000 MHz	
Attenuation		Fixed Range Accuracy	0 ± 0.10	10 ± 0.25	dB dB dB	
Phase Change Vs. Attenuation		+0.1 +2.0	± 1 ± 5	DEG DEG	10 - 300 MHz 300 - 1000 MHz	
VSWR		1.1/1	1.3/1			
Impedance		50		OHMS		
Switching Speed		58	100	nSec	50% TTL to 90% / 10% RF	
Transition (Rise/Fall) Time		32		nSec	10% / 90% - 90% / 10% RF	
Switching (Video) Transients		24		mV	Peak Value	
Intercept Points		2nd 3rd	+100 +40	dBm dBm	214 MHz / 127 MHz 107 MHz / 127 MHz	
RF Power		Operate No Damage	+18 +28 +30	dBm dBm dBm	0.1 dB Compression 0.1 dB Comp., 500 - 700 MHz	
Operating Temperature	-55	+25	+125	$^{\circ}$ C	TA	

