



**MODEL NO.  
CSW88064**

**Switch SP8T**

**FEATURES**

- 120 - 2800 MHz
- 2 dB Insertion Loss
- 100 nSec Switching Speed
- BCD Control

**SP8T**

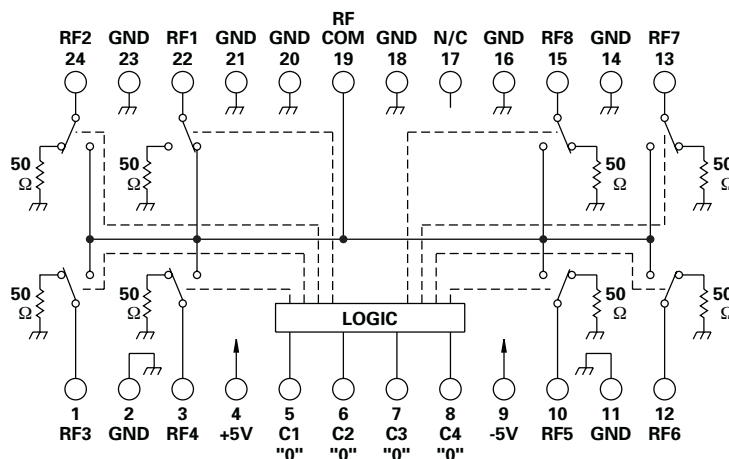
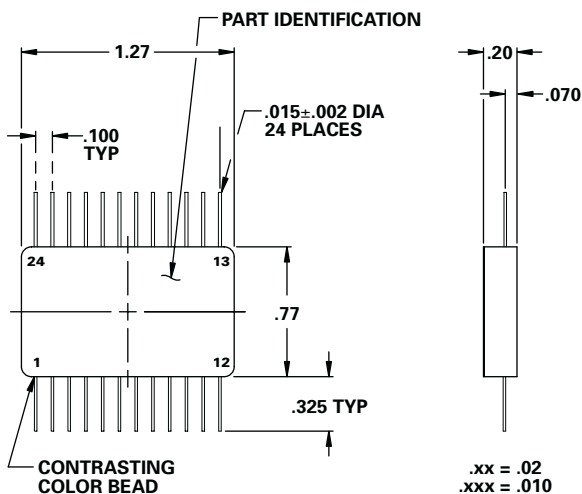

LOGIC TABLE				
CONTROL INPUT				RF COM TO
C4	C3	C2	C1	
0	0	0	0	RF1
0	0	0	1	RF2
0	0	1	0	RF3
0	0	1	1	RF4
0	1	0	0	RF5
0	1	0	1	RF6
0	1	1	0	RF7
0	1	1	1	RF8
1	X	X	X	ALL OFF

**GUARANTEED PERFORMANCE**

Parameter	Min	Typ	Max	Units	Conditions
Operating Frequency	120		2800	MHz	
DC Current			10 10	mA	At +5 VDC Supply At -5 VDC Supply
Control Type		TTL			BCD, See Table
Control Current	High Low		±1 ±1	µA	V <sub>IH</sub> = +2.7 V V <sub>IL</sub> = +0.5 V
Insertion Loss		1.8 2.0	2.0 2.8	dB	120 - 2000 MHz 2000 - 2800 MHz
Isolation	50 40 30	40		dB	120 - 500 MHz 500 - 2000 MHz 2000 - 2800 MHz
VSWR	Thru		1.4/1		
Impedance		50		OHMS	
Switching Speed			100	nSec	50% TTL to 90% / 10% RF
Transition (Rise/Fall) Time		30		nSec	10% / 90% or 90% / 10% RF
Switching (Video) Transients		50		mV	Peak Value
Intercept Points	2nd 3rd	+60 +30		dBm	
RF Power	0.1 dB Comp 0.1 dB Comp No Damage	+10	+10 +17 +27	dBm	120 - 300 MHz 300 - 2800 MHz
Operating Temperature	-20	+25	+70	°C	TA
Storage Temperature	-45		+85	°C	TA