

MODEL NUMBER DSW79177

Switch SP7T

FEATURES

- 800-2050 MHz
- 3 Line BCD Control
- 40 NSec Switching Speed
- Small Size
- +75 dBm IP2
- Non-Reflective

SP7T

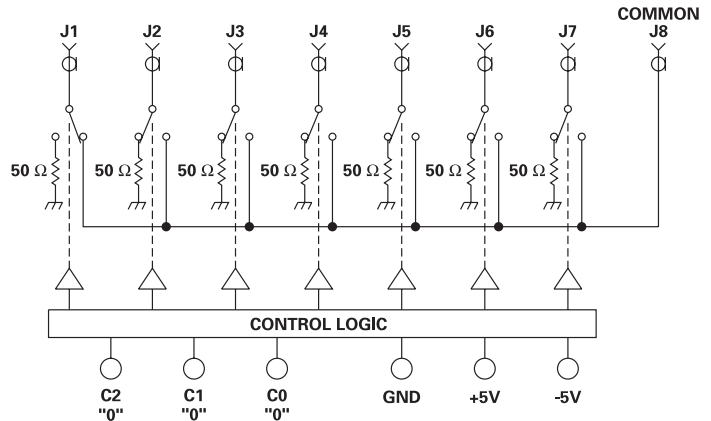
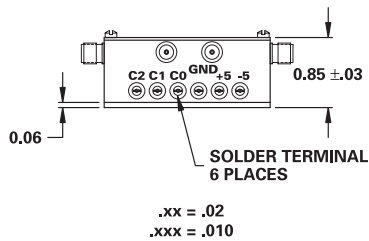
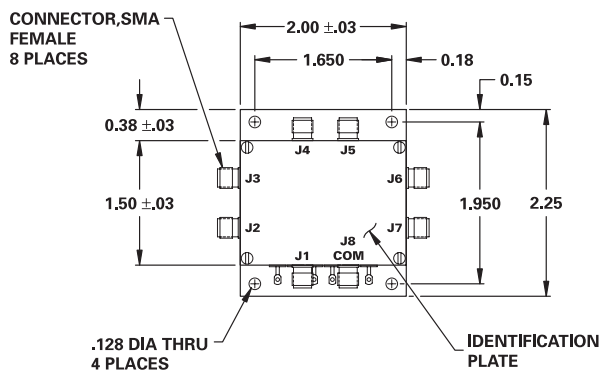

LOGIC TABLE

C2	C1	C0	THRU
0	0	0	J8 to J1
0	0	1	J8 to J2
0	1	0	J8 to J3
0	1	1	J8 to J4
1	0	0	J8 to J5
1	0	1	J8 to J6
1	1	0	J8 to J7
1	1	1	All Off

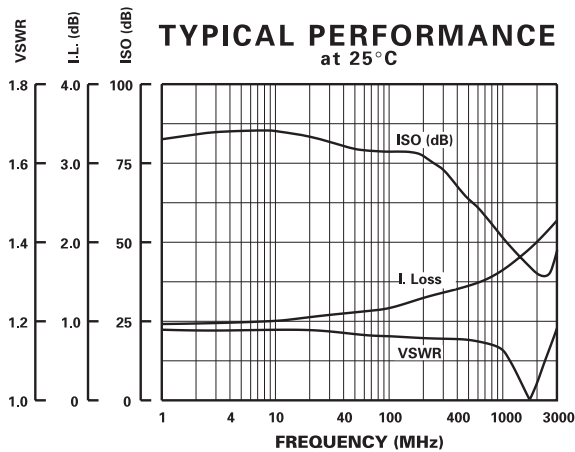

GUARANTEED PERFORMANCE

Parameter	Min	Typ	Max	Units	Conditions
Operating Frequency	800		2050	MHz	
DC Current		0.027 0.037	3 5	mA	At +5 VDC Supply At -5 VDC Supply
Control Type		TTL			3 Line BCD See Table
Control Current	High Low	0 0	2 2	μA	V _{IH} = +2.7V V _{IL} = +0.5V
Isolation		40	44	dB	
Insertion Loss		1.6 2.0	2.0 2.5	dB	800 - 950 MHz 1750 - 2050 MHz
VSWR	Thru Termination	1.18/1 1.13/1	1.6/1 2.0/1		
Impedance		50		OHMS	
Switching Speed		40	75	nSec	50% TTL to 90% / 10% RF
Transition (Rise/Fall) Time		4		nSec	10% / 90% or 90% / 10% RF
Switching (Video) Transients		39		mV	Peak Value
Intercept Points	2nd 3rd	+75 +38		dBm	
RF Power	Operate	+14.6 +20	+12 +18	dBm	0.1 dB Compression 1 dB Compression
Operating Temperature		0	+25	°C	TA



DAICO Industries

310.507.3242 • FAX 310.507.5701 • www.daico.com