

MODEL NUMBER CDS0621

Pin Diode SPST

FEATURES

- 20-2000 MHz
- 6 mA, +5 VDC
- 70 dB Isolation
- TTL Driver
- Non-Reflective
- Replaceable SMA Connectors

SPST

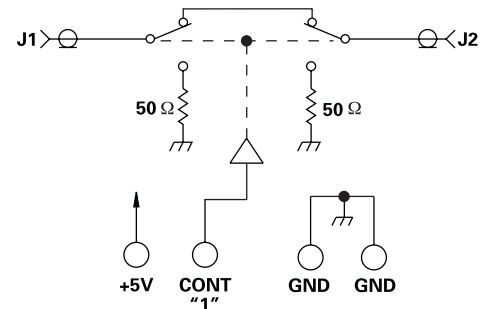
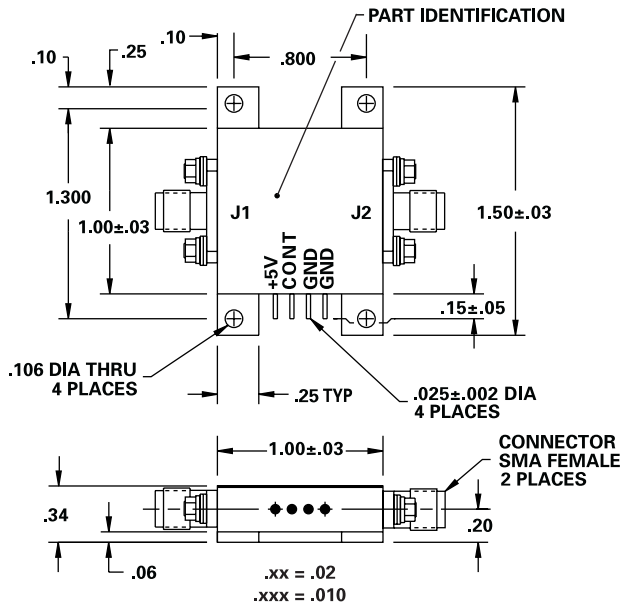

GUARANTEED PERFORMANCE

Parameter	Min	Typ	Max	Units	Conditions
Operating Frequency	20		2000	MHz	
DC Current		6.0	12	mA	At +5 VDC Supply
Control Type		TTL			1 Line Logic "0" = Isolation Logic "1" = Thru
Control Current		0	±10	µA	VIH = +2.7V VIL = +0.5V
Insertion Loss		0.95	1.5	dB	20 - 1000 MHz
		1.30	2.0	dB	1000 - 2000 MHz
Isolation	60	70		dB	20 - 1000 MHz
	50	60		dB	1000 - 2000 MHz
VSWR		1.15/1	1.30/1		
	Termination	1.15/1	1.50/1		
Impedance		50		OHMS	
Switching Speed		1.4	3.0	µSEC	50% TTL to 90% / 10% RF
Transition (Rise/Fall) Time		0.3		µSEC	90% / 10% or 10% / 90% RF
Switching Transients		400		mV	Peak Value
Intercept Points	2nd	+70		dBm	50 MHz / 70 MHz
	3rd	+38		dBm	50 MHz / 35 MHz
RF Power	Operate	+15	+10	dBm	20 - 100 MHz
	No Damage	+20	+17	dBm	100 - 2000 MHz
Operating Temperature	-55	+25	+125	°C	TA

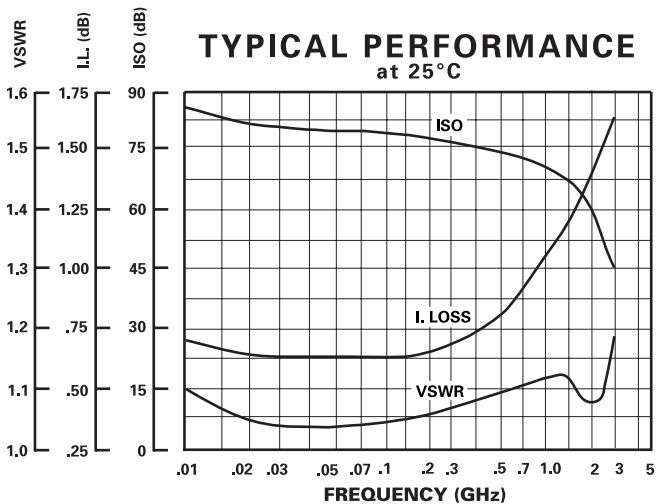

DAICO Industries

310.507.3242 • FAX 310.507.5701 • www.daico.com