

MODEL NUMBER DS0432

2 Watt PIN Diode SP2T

FEATURES

- 200-900 MHz
- 2 Watts CW
- 0.3 dB Insertion Loss
- Non-Reflective
- TTL Driver
- 14 Pin DIP

SP2T

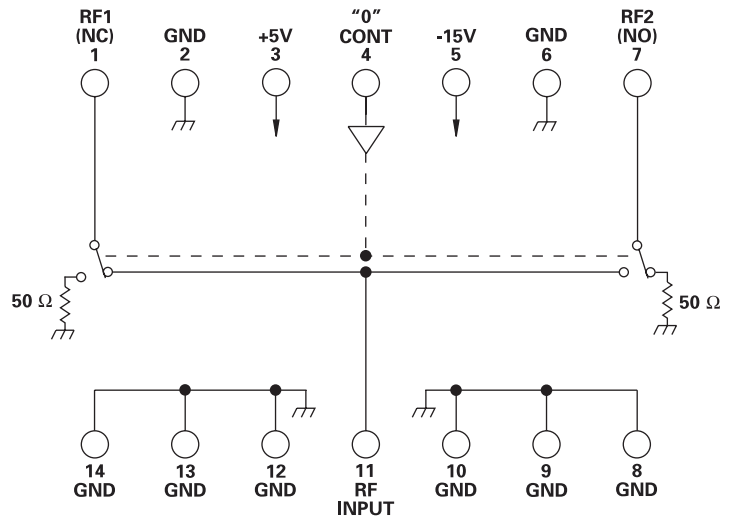
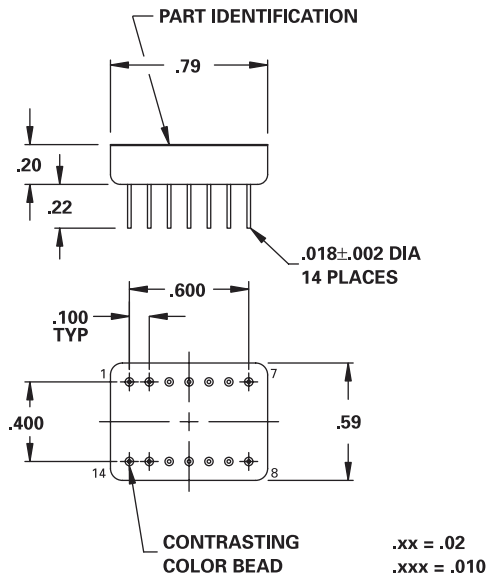

GUARANTEED PERFORMANCE

Parameter	Min	Typ	Max	Units	Conditions
Operating Frequency	200		900	MHz	
DC Current		22 23	30 30	mA	At +5 VDC Supply At -15 VDC Supply
Control Type		TTL			1 Line Logic "0" = RF IN to RF 1 Logic "1" = RF IN to RF 2
Control Current			+40 -0.8	μA	V _{IH} = +2.7V V _{IL} = +0.5V
Insertion Loss		0.3	0.8	dB	
Isolation	35	45		dB	
VSWR		1.1/1	1.25/1		
Impedance		50		OHMS	
Switching Speed		0.7	1.5	μSEC	50% TTL to 90% / 10% RF
Intercept Points		3rd	+47		
RF Power			+36 +35 +20	dBm	Operate No Damage Thru No Damage Termination
Operating Temperature	-55	+25	+85	°C	TA

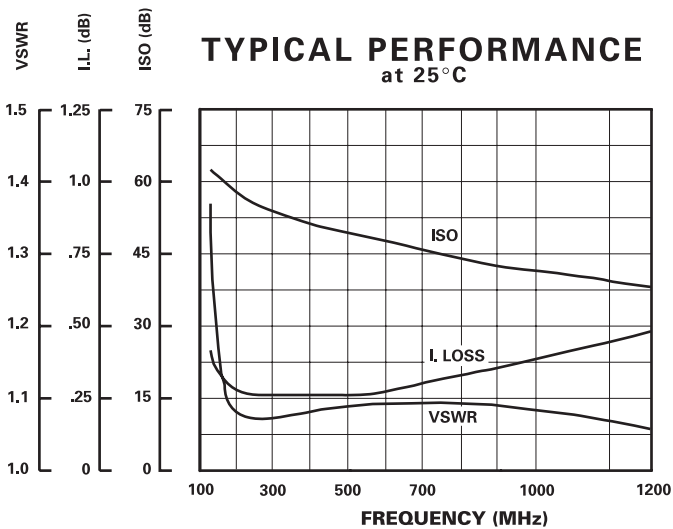

DAICO Industries

310.507.3242 • FAX 310.507.5701 • www.daico.com