

**MODEL NUMBER
DSW28000**

GaAs SP2T

FEATURES

- 5- 2000 MHz
- 30 nSec Switching Speed
- 13 mV Transients
- 1.6 mA @ +5 VDC
- 14 Pin Flatpack

SP2T

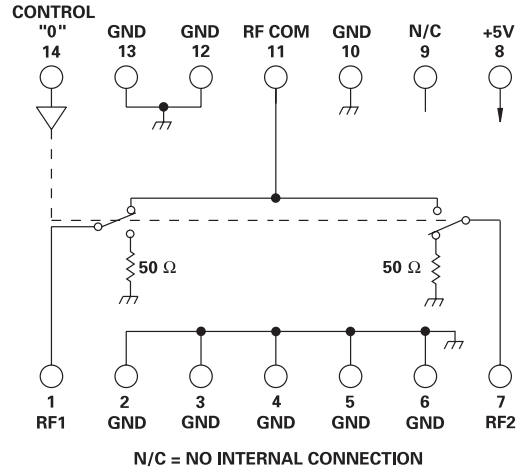
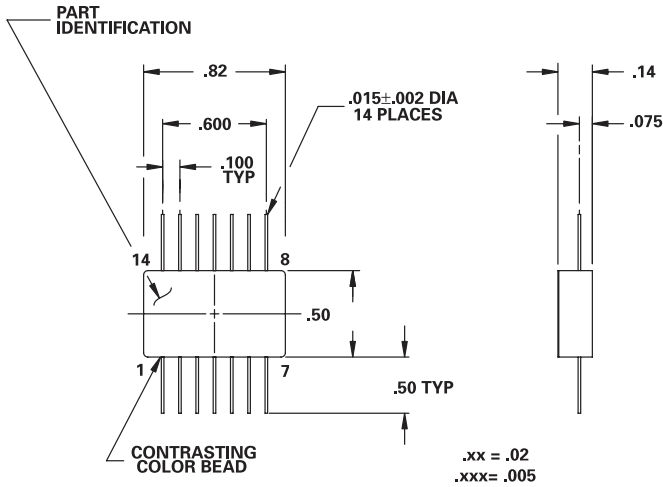

GUARANTEED PERFORMANCE

Parameter	Min	Typ	Max	Units	Conditions
Operating Frequency	5		2000	MHz	
DC Current		1.6	5	mA	At +5 VDC Supply
Control Type		TTL			1 Line Logic "0" = RF COM to RF1 Logic "1" = RF COM to RF2
Control Current	High Low	1 1	±40 ±40	µA	VIH = +3.0V VIL = +0.5V
Insertion Loss		1.0 1.2 1.4	1.4 1.6 2.0	dB	5 - 500 MHz 500 - 1000 MHz 1000 - 2000 MHz
Isolation		53 45 40 35	57 53 46 40	dB	5 - 300 MHz 300 - 500 MHz 500 - 1000 MHz 1000 - 2000 MHz
VSWR	Thru Termination	1.2/1 1.2/1 1.2/1 1.3/1 1.2/1 1.2/1	1.4/1 1.5/1 1.9/1 1.4/1 1.5/1 1.9/1	dB	5 - 500 MHz 500 - 1000 MHz 1000 - 2000 MHz 5 - 500 MHz 500 - 1000 MHz 1000 - 2000 MHz
Impedance		50		OHMS	
Switching Speed		24	30	nSEC	50% TTL to 90% / 10% RF
Transition (Rise/Fall) Time		8	10	nSEC	90% / 10% or 10% / 90% RF
Switching (Video) Transients		13	120	mV	Peak Value
Intercept Points	2nd 3rd	+52 +34	+62 +48	dBm	150 MHz / 350 MHz 50 - 2000 MHz 200 MHz / 350 MHz 50 - 2000 MHz
RF Power	Operate No Damage	+17 +21 +22	+10 +17 +21 +24	dBm	1.0 dB Comp 5 - 50 MHz 1.0 dB Comp 50 - 500 MHz 1.0 dB Comp 500 - 2000 MHz
Operating Temperature		-55	+25	+85	°C TA

