

**MODEL NUMBER
DS0613**

PIN Diode SP2T

FEATURES

- 5-2000 MHz
- TTL Driver
- 14 Pin DIP

SP2T

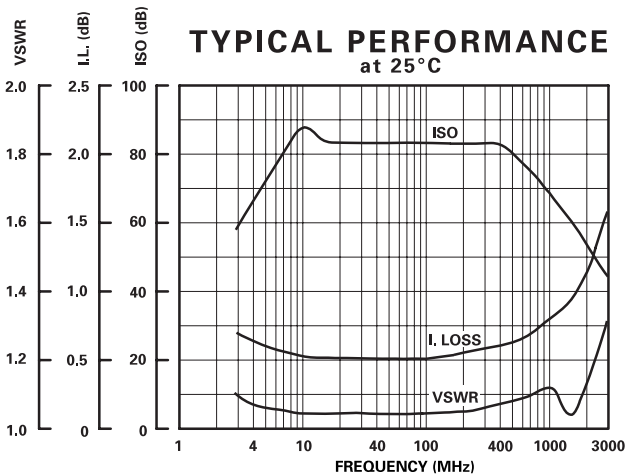
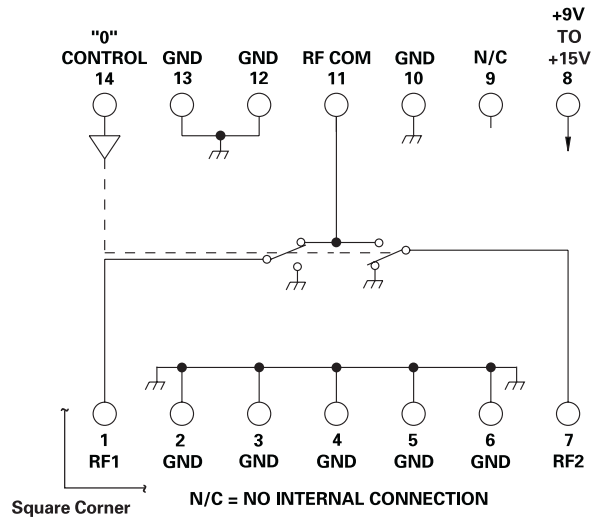
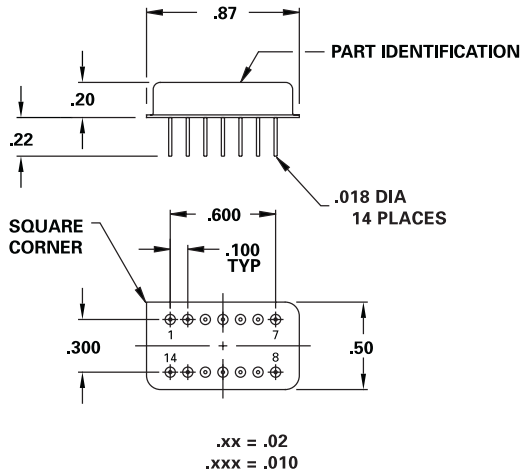

GUARANTEED PERFORMANCE

Parameter	Min	Typ	Max	Units	Conditions
Operating Frequency	5		2000	MHz	
DC Current		24	35	mA	At +9 to +15 VDC Supply
Control Type		TTL			1 Line Logic "0" = COM to RF1 Logic "1" = COM to RF2
Control Current	High	1	±10	µA	VIH = +2.7V
	Low	1	±10	µA	VIL = +0.5V
Insertion Loss		0.7	1.0	dB	5 - 500 MHz
		1.0	1.5	dB	500 - 1000 MHz
		1.2	1.7	dB	1000 - 2000 MHz
Isolation	60	70		dB	5 - 10 MHz
	70	80		dB	10 - 500 MHz
	60	70		dB	500 - 1000 MHz
	50	60		dB	1000 - 2000 MHz
VSWR	Thru	1.15/1	1.25/1		5 - 10 MHz
		1.10/1	1.20/1		10 - 1000 MHz
		1.15/1	1.50/1		1000 - 2000 MHz
Impedance		50		OHMS	
Switching Speed		2	3	µSEC	50% TTL to 90% / 10% RF
Transition (Rise/Fall) Time		0.5		µSEC	90% / 10% or 10% / 90% RF
Switching (Video) Transients		360	700	mV	Peak Value
Intercept Points	2nd	+60	+78	dBm	150 MHz / 350 MHz
	3rd	+30	+45	dBm	200 MHz / 350 MHz
RF Power	Operate	+7	0	dBm	5 - 20 MHz
		+15	+10	dBm	20 - 50 MHz
		+20	+13	dBm	50 - 2000
	No Damage		+27	dBm	
Operating Temperature	-55	+25	+125	°C	TA