

**MODEL NUMBER
DSW25038**

GaAs SP2T

FEATURES

- DC - 2000 MHz
- 2 nSec Transition Time
- 5 nSec Switching Speed
- 10 mV Transients
- TTL Control
- Low Cost
- Ultra Small 0.270 SQ Surface Mount Package

SP2T

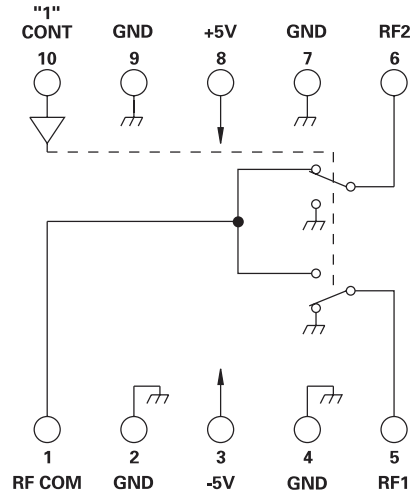
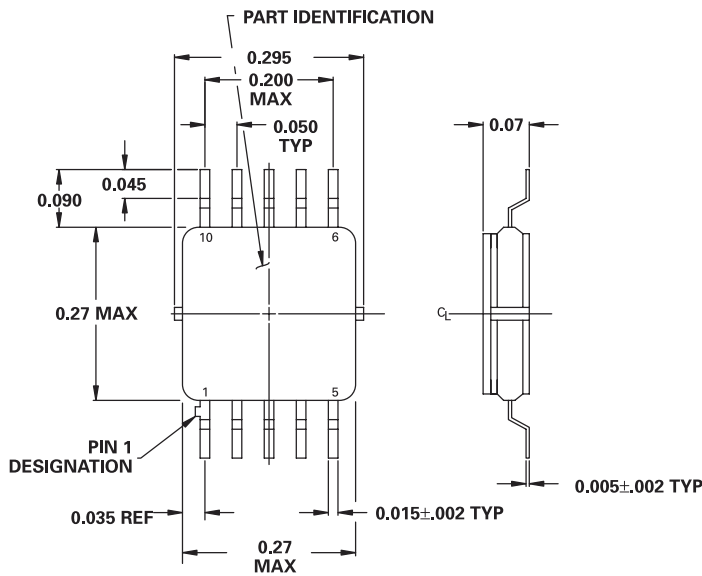

GUARANTEED PERFORMANCE

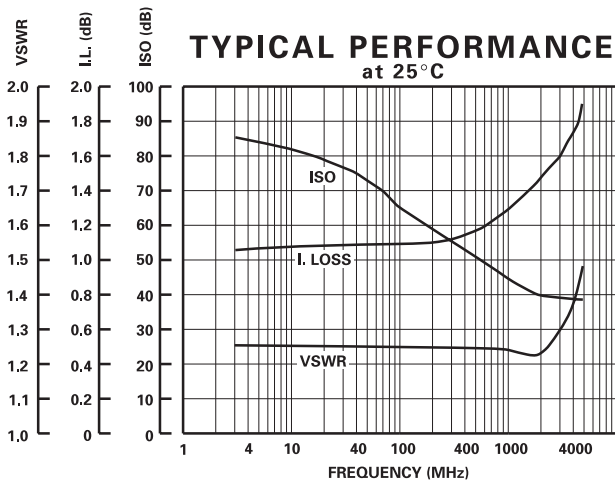

Parameter	Min	Typ	Max	Units	Conditions
Operating Frequency	DC		2000	MHz	
DC Current		13	25	mA	At +5 VDC Supply
		10	20	mA	At -5 VDC Supply
Control Type		TTL			1 Line Logic "0" = RF Com to RF 1 Logic "1" = RF Com to RF 2
Control Current	High	10	±50	µA	V _{IH} = +2.7V
	Low	10	±50	µA	V _{IL} = +0.5V
Insertion Loss		1.5	2.0	dB	DC - 1 GHz
		1.8	2.5	dB	1 - 2 GHz
Isolation	60	68		dB	DC - 100 MHz
	40	50		dB	100 MHz - 500 MHz
	35	42		dB	500 MHz - 1 GHz
	30	37		dB	1 GHz - 2 GHz
VSWR		1.3/1	1.5/1		DC - 1 GHz
		1.5/1	1.7/1		1 GHz - 2 GHz
Impedance		50		OHMS	
Switching Speed		13	25	nSEC	50% TTL to 90% / 10% RF
Transition (Rise/Fall) Time		3	5	nSEC	10% / 90% or 90% / 10% RF
Switching (Video) Transients		11		mV	Peak Value
Intercept Points	2nd	+50	+55	dBm	150 MHz / 450 MHz
	3rd	+23	+26	dBm	50 MHz / 70 MHz
RF Power	Operate	+4	0	dBm	0.1 dB Comp DC - 10 MHz
		+8	+5	dBm	10 MHz - 100 MHz
		+11	+7	dBm	100 MHz - 2 GHz
			+30	dBm	No Damage
Operating Temperature	-55	+25	+85	°C	TA