

SP2T

FEATURES

- DC - 450 MHz
- 50Ω or 75Ω Terminations
- 20 Watts CW
- SMA Connectors
- Diode Suppression of Switching Transients



MODEL NO. 100C0611

SP2T Relay

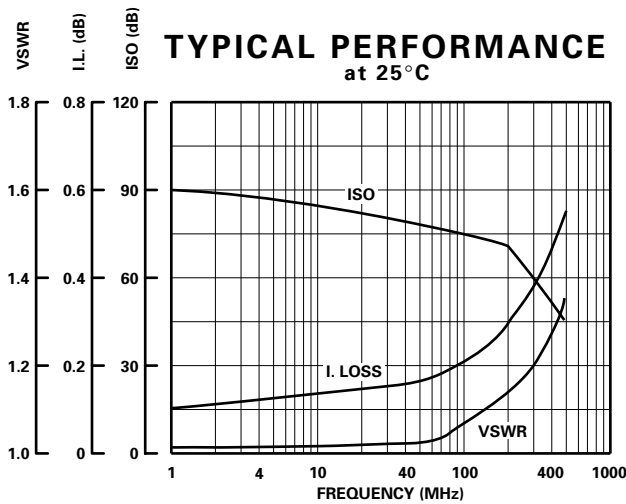
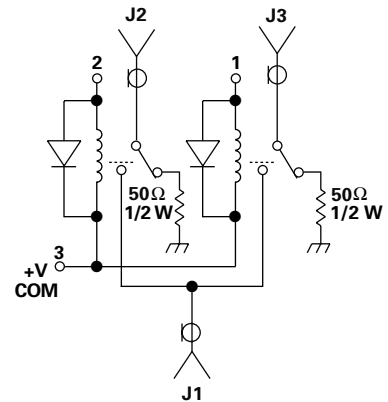
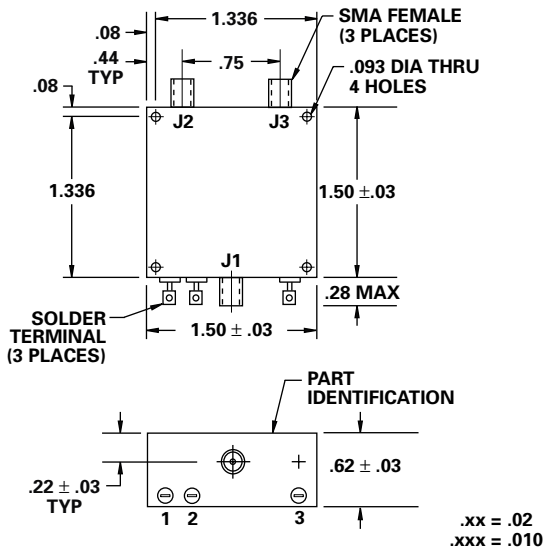

GUARANTEED PERFORMANCE

Parameter	Min	Typ	Max	Units	Conditions
Operating Frequency	DC		450	MHz	
DC Voltage					See Table
Insertion Loss		0.1	0.2	dB	DC - 50 MHz
		0.3	0.35	dB	50 - 250 MHz
		0.5	0.60	dB	250 - 450 MHz
Isolation	70	80		dB	DC - 50 MHz
	55	65		dB	50 - 250 MHz
	45	50		dB	250 - 450 MHz
VSWR	Thru	1.05/1	1.15/1		DC - 50 MHz
		1.15/1	1.2/1		50 - 250 MHz
		1.3/1	1.4/1		250 - 450 MHz
Impedance		50		OHMS	
Switching Speed			5	mSEC	
RF Power	Operate		20	W	CW
Operating Temperature	-55	+25	+85	°C	TA

PART NO. EXAMPLE
100C0611 - 6 - F/S - R - 75

Basic Part Number: 100C0611

Dash No. for Coil Voltage (See Table): 6

"F/S" for Failsafe J1 to J2 omit for Standard.

R: Add for 75 Ω Termination. Omit for 50 Ω Termination.

75: For Reverse Polarity of Diodes. Omit for Standard. See Schematic for Standard.

CONTROL VOLTAGE TABLE

Voltage	Current - Typical
6	65 mA
12	32 mA
18	21 mA
26	17 mA