

FEATURES

- 1550 - 1850 MHz
- 4 dB Gain
- Non-Reflective
- TTL Driver
- Replaceable SMA Connectors



**MODEL NO.
CDS0892**

Connectorized SP2T w/ Amp

HDI

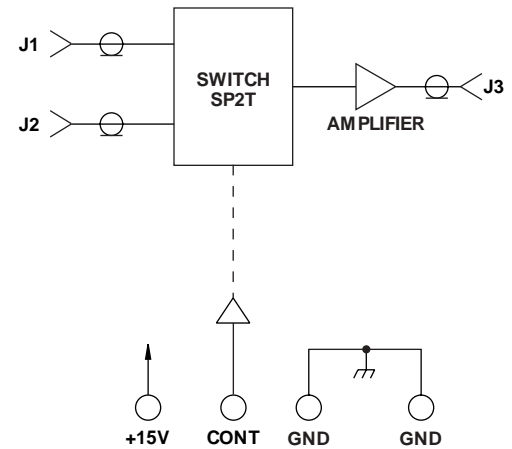
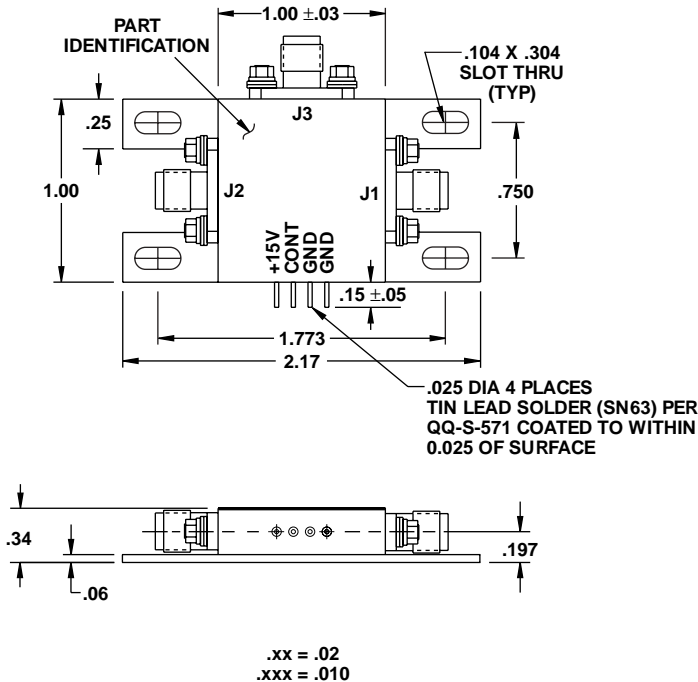

GUARANTEED PERFORMANCE

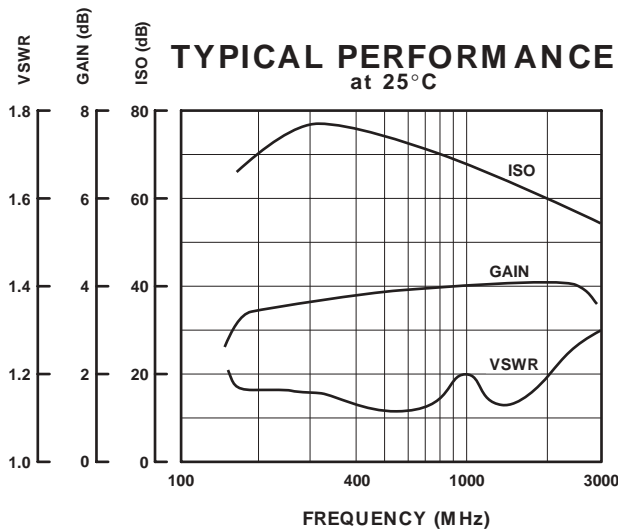

Parameter	Min	Typ	Max	Units	Conditions
Operating Frequency	1550		1850	MHz	
DC Current		71	100	mA	At +15 VDC Supply
Control Type		TTL			1 Line Logic "0" = J2 - J3 Logic "1" = J1 - J3
Control Current		0	60	μA	VIH = +2.7 V VIL = +0.5 V
		-0.5	-1.6	mA	
Insertion Gain		3	4	5	dB
			±0.1	±0.5	
			8.2	10	
Isolation		45	59		dB
VSWR					
			1.17/1	1.5/1	
			1.12/1	1.5/1	
Impedance		50		OHMS	
Switching Speed		0.6	1	μSec	50% TTL to 90% / 10% RF
Transition (Rise/Fall) Time		340	700	nSec	90% / 10% or 10% / 90% RF
Switching (Video) Transients		1.3		V	Peak Value
Intercept Points					
	2nd	+47		dBm	350 / 150 MHz
	3rd	+31		dBm	175 / 200 MHz
RF Power					
	Operate	+2	-1	dBm	0.1 dB Input Compression
	No Damage		+5	dBm	
Operating Temperature	-55	+25	+100	°C	TA