

**FEATURES**

- 1300 - 1700 MHz
- 45° LSB, 315° Range
- ±1.0 dB Balance between Outputs
- +20 dBm Output Compression
- Molybdenum Case for Heat Transfer
- Integrated GaAs FET Amplifiers, MMIC SPST Blanking Switch, Passive Power Divider, 3 Section Phase Shifter, and TTL and ECL Drivers/Control



**MODEL NO.  
DP0877**

**3 Section Phase Shifter /  
Amplifier / Switch**

MFD

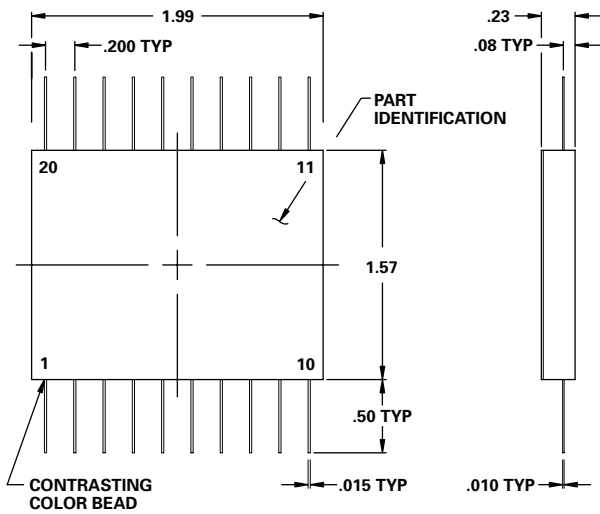

.xx = .02  
.xxx = .010

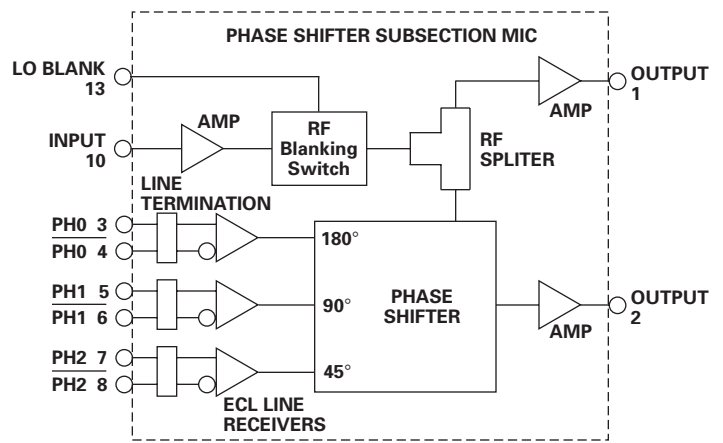

**GUARANTEED PERFORMANCE**

Parameter	Min	Typ	Max	Units	Conditions
Operating Frequency	1300		1700	MHz	
DC Current		1000 200 100		mA mA mA	At +15 VDC Supply At +5 VDC Supply At -5 VDC Supply
Control Type		ECL TTL			For Phase Shifter For Blanking Switch
Insertion Gain		18		dB	Between Outputs
Balance		±1.0		dB	
Noise Figure		10		dB	
Isolation		45 20		dB dB	Input to Outputs Between Outputs
Phase Shift		45	315	DEG	45, 90, 180
LSB	0			DEG	
Range Accuracy		±5.0		DEG	
VSWR			2.0/1		
Impedance		50		OHMS	
Switching Speed			300	nSec	50% TTL to 10% / 90% RF
RF Power		+20	+15	dBm dBm	1.0 dB Compression
Operate No Damage					
Operating Temperature	0	+25	+71	°C	TA