

## FEATURES

- 1243 - 1253 MHz
- 45° LSB, 315° Range
- ECL Driver
- Integrated Power Divider For REF Channel
- Integrated Amplifier For Equal Insertion Loss



**MODEL NO.  
DPS38017**

**3 Section Phase Shifter**

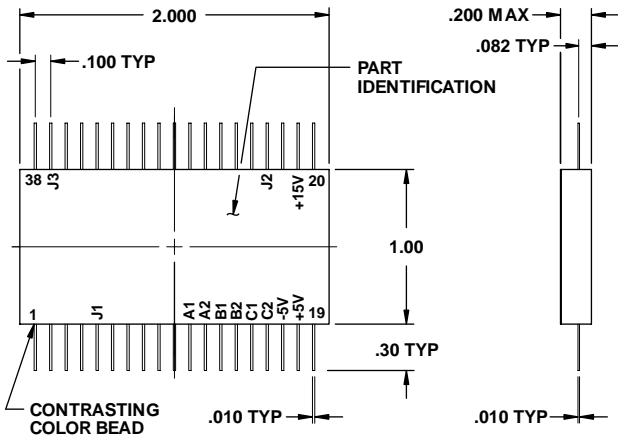

.xx = .02  
.xxx = .010

**LOGIC TABLE**

Control Logic			Phase State	Nominal Phase Shift (DEG)
C	B	A		
0	0	0	PS0	0
0	0	1	PS1	45
0	1	0	PS2	90
0	1	1	PS3	135
1	0	0	PS4	180
1	0	1	PS5	225
1	1	0	PS6	270
1	1	1	PS7	315

**LOGIC "1"**

CTL 1 = -0.6V to -1.0V  
CTL 2 = -1.4V to -1.9V

**LOGIC "0"**

CTL 1 = -1.4V to -1.9V  
CTL 2 = -0.6V to -1.0V

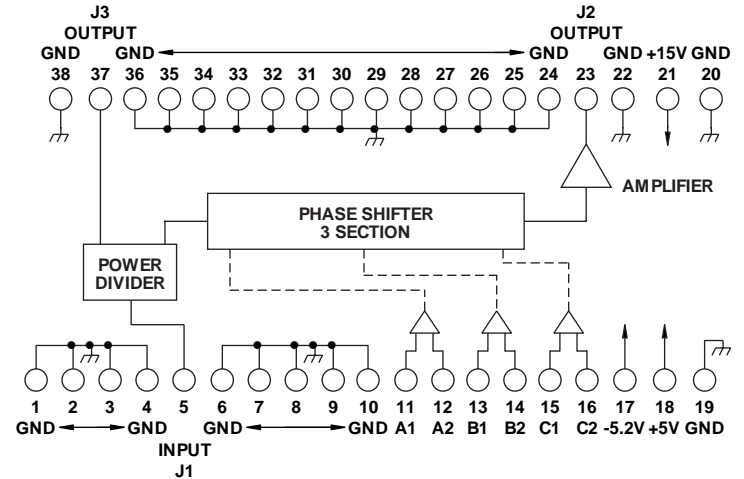

## GUARANTEED PERFORMANCE

Parameter	Min	Typ	Max	Units	Conditions
Operating Frequency	1243		1253	MHz	
DC Current			65 98 90	mA	At +15 VDC Supply At +5 VDC Supply At -5.2 VDC Supply
Control Type		ECL			3 Line Logic "1" = Phase Shift
Insertion Gain			3.7 4.5	dB	At 25°C Over Temperature
Insertion Loss Balance			±1.0	dB	J2 With Respect to J3
Isolation	20			dB	Between J2 and J3
Phase Shift			45	DEG	45, 90, 180 For the 180° Shift Only For all Other Shifts
		0	315	DEG	
			±5 ±20	DEG	
VSWR			1.6/1		
Impedance		50		OHMS	
Switching Speed			2	µSec	50% TTL - 10% / 90% RF
Transition (Rise/Fall) Time				µSec	10% / 90% - 90% / 10% RF
Switching (Video) Transients				mV	Peak Value
Intercept Points				dBm	
				dBm	
RF Input Power				dBm	1.0 dB Compression
				dBm	
Operating Temperature	-54	+25	+71	°C	TA