

FEATURES

- 450 - 600 MHz
- High Isolation
- TTL Driver
- Terminated Switches
- SMA Connectors



**MODEL NO.
CSWX9023**

4x5 Switch Matrix

HDI

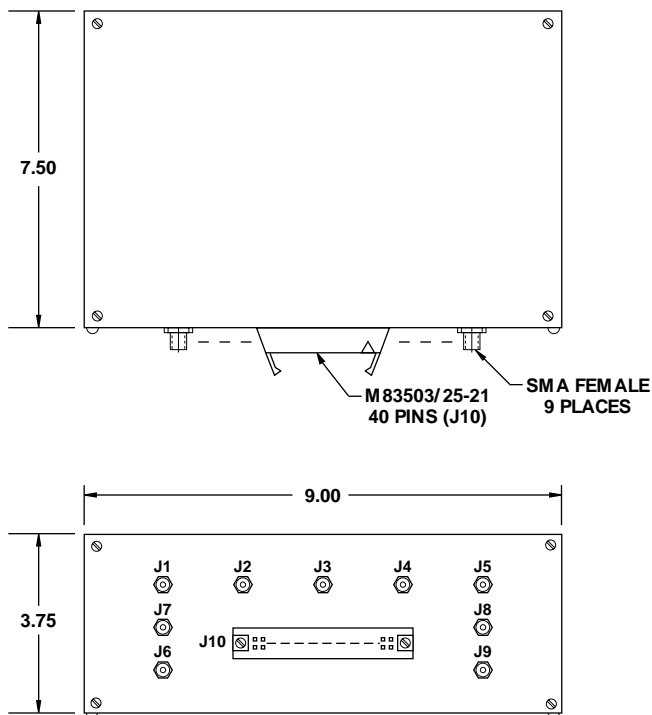

.xx = .02
.xxx = .010

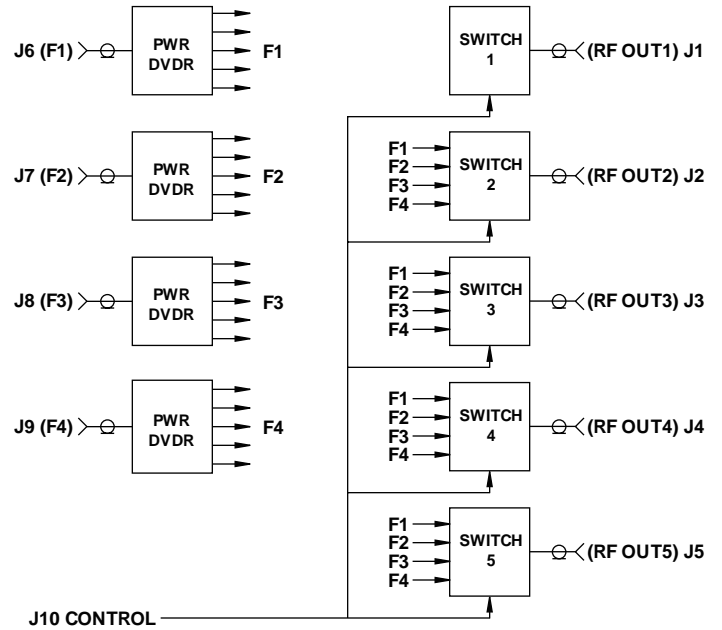

GUARANTEED PERFORMANCE

Parameter	Min	Typ	Max	Units	Conditions
Operating Frequency	450		600	MHz	
DC Current		85	150	mA	At +5 VDC Supply
Control Type		TTL			See Control Table
Control Current				μ A	
	High	1	40		$V_{IH} = +2.7$ V
	Low	.01	-1.6		$V_{IL} = +0.5$ V
Insertion Loss		10.4	11.5	dB	
Isolation	75	76		dB	Between Selected and Non-Selected Inputs as Measured at the Corresponding Output
VSWR		1.4	2/1		
Impedance		50		OHMS	
Switching Speed		2.4	3	μ Sec	50% TTL to 10% / 90% RF
Transition (Rise/Fall) Time		18		μ Sec	10% / 90% to 90% / 10% RF
Switching (Video) Transients		850		mV	
Intercept Poing				dBm	
	2nd	+85			
	3rd	+50			
RF Power			+32	dBm	Operate
	No Damage				
Operating Temperature	0	+25	+65	$^{\circ}$ C	TA